

GCSE BIOLOGY

Brochez B.F.J.

JOSHUA KABESHA '00P

This book was downloaded at www.bio.com by Chewe Chota.

KABESHA'S DEDICATIONS

Email me @ this address : joshua.kabesha@yahoo.com

joshua kabz BIOLOGY OLIVEFI

Revised Edition

Created by Bernard Brochez

JOSHUA KABEZ COPY OF BIOLOGY FILE

GCSE BIOLOGY

Brochez B.F.J.

JOSHUA KABEZ COPY OF BIOLOGY FILE

joshua.kabesha@yahoo.c

Revised Edition

JOSHUA KABEZ COPY

Created by Bernard Brochez

Acknowledgements

I am very grateful to all the people who have provided help in the making of this book. Special thanks go to my wife Lucy, who was very supportive and understanding, particularly during the hours that I spent behind my computer.

I would like to express my gratitude towards the management of Ibenga Girls Secondary School. They made me feel at home away from home.

I would also like to thank my parents, who supported me during my studies, and who had to miss me for the eight years that I've spent in Ibenga -Luanshya -ZAMBIA.

This book was downloaded at www.bio.com by Joshua who lives in Chambishi at House no 24 chundanounde

joshua.kabesha@yahoo.c

JOSHUA KABESHA

Created by Bernard Brochez

Reference Books

- Biology third edition, Arms and Camp © 1987
- Introduction To Biology, D.G. McKean © 1974
- GCSE Biology, D.G. Mackean © 1994
- Focusing on health, J.H. Haag © 1978
- Biology a functional approach, M.B.V. Roberts © 1979

Own University notes Ghent

Photo and drawing credits.

Corel Draw © 1996

Fig. 4.4, 6.5, 6.6, 6.9, 6.10, 6.11, 7.1, 7.3, 8.10, 9.5, 9.6, 9.7, 10.3, 10.6, 11.1, 11.2, 11.5, 11.6, 14.1, 14.2, 14.4, 14.5, 16.5, 17.1, 22.1, 22.3, 22.7, 22.8, 22.9, 22.13, 23.1.

Microsoft Encarta © 1996

Fig.1.1, 1.2, 3.2, 3.3, 3.5, 4.1, 6.7, 6.8, 7.2, 9.4, 10.2, 10.5, 12.2, 13.2, 14.3, 14.6, 17.3, 17.5, 17.6, 17.7, 18.6, 18.8, 19.1, 19.9, 19.10, 21.1, 22.2, 22.4, 22.6, 22.10, 22.11, 22.12, 22.14

Biology Third Edition Arms and Camp © 1987

Fig. 2.1, 2.3, 2.7, 2.8, 3.4, 8.2, 8.3, 8.10, 13.1, 14.8, 14.9, 14.10, 14.11, 14.12, 18.1, 18.2, 18.3, 18.4, 19.2, 24.2, 24.17, 25.1, 25.2

GCSE Biology D.G. McKean © 1986

Fig. 2.4, 2.5, 2.6, 2.11, 4.10, 6.1, 6.2, 9.5

All other figures, not mentioned above, are from various sites on the internet. Some of them carry copyright.

© Copyright 1998

© Copyright 2006 Revised Edition

All rights reserved. No part of this publication may be reproduced in any form or by any means without permission in writing from the author. The computer drawings are by the author, (unless otherwise stated) whose copyright they are, and whose permission should be sought before they are reproduced or adapted in other publications.

Requests for permission to make copies of any part of the work should be mailed to:

Fam. Brochez - Van Laere,
Hoenderveldstraat 2,
9800 Deinze
Belgium.

First Print in Ibenga, Luanshya, Zambia
Bound at Mission Press, Ndola Zambia

Created by Bernard Brochez

To the student

These notes were made based on the Examination syllabuses for 1996, from the University of Cambridge (International Examinations)

This book should not be considered as a textbook. Information has been nicely spaced out and put in such a way, that it should be easy to use during biology-lessons and study-time.

When writing this book, I kept in mind that you, the student, still need tuition from your teacher. He or she can still give you extra information or leave out some. Therefore, consider this book as a guide to help you get the needed information.

To be successful in Biology, a certain amount of time should be investigated in studying the matter by heart.

Understanding the subject is ONE thing, being able to explain it yourself to others (Examination) is another.

I compiled these notes for you, the student, bearing in mind that sometimes classes are left without a Biology teacher, for whatever reason (illness, funeral, delays in being posted...)

You can use these notes during your biology lessons, bearing in mind that you first have to consult your Biology teacher or Headmaster/Headmistress.

He/she is the one who will know if the syllabus has changed, or if there is any latest information on some subjects. For example, I can imagine that the topic Aids-HIV will be a lot different in the year 2010, than it is now. Hopefully, we will have found a cure by then.

When using this edition, you will notice that your teacher not always follows the syllabus order. The reason being that some topics are better dealt with at a later stage, when the student has obtained the needed knowledge to fully comprehend the subject matter.

The order, he or she chooses is based on their own experiences, and should be taken as ideal. It is very possible that another teacher might follow a different order.

It is my sincere hope that you can put this book into good use, and that it might help you to obtain your desired marks for the subject BIOLOGY.

Bernard F.J. Brochez.

Senior Biology Teacher 1991-1998
Ibenga Girls Secondary School
P.B 1 Masaiti - LUANSHYA
ZAMBIA

Created by Bernard Brochez

CONTENTS

INTRODUCTION	7
1. CELL STRUCTURE AND ORGANISATION.	9
2. DIFFUSION AND OSMOSIS.	14
3. ENZYMES.	24
4. NUTRITION IN GREEN PLANTS - PHOTOSYNTHESIS.	29
5. MINERAL NUTRITION IN PLANTS.	44
6. NUTRITION AND DIGESTION IN MAN.	46
7. TEETH.	59
8. TRANSPORT IN FLOWERING PLANTS	63
9. TRANSPORT IN MAN – CIRCULATORY SYSTEM	74
10. RESPIRATION.	85
11. SUPPORT, MOVEMENT AND LOCOMOTION.	90
12. EXCRETION.	96
13. HOMEOSTASIS.	102
14. CO-ORDINATION AND RESPONSES.	105
15. TROPISMS AND TACTIC RESPONSES.	119
16. USE AND ABUSE OF DRUGS.	122
17. DIVERSITY OF ORGANISMS.	132
18. RELATIONSHIPS: ORGANISMS WITH ONE ANOTHER AND WITH THE ENVIRONMENT.	141
19. EFFECTS OF MAN ON THE ECOSYSTEM.	150
20. ASEXUAL REPRODUCTION.	162
21. SEXUAL REPRODUCTION IN PLANTS.	165
22. SEXUAL REPRODUCTION IN MAN.	170
23. SEXUALLY TRANSMITTED DISEASES.	183
24. GENETICS AND INHERITANCE.	187
25. SELECTION.	206
26. BIOLOGY PRACTICALS.	210

**TOSHITA
AND
KARESHA'S FAN**

Created by Bernard Brochez

INTRODUCTION

Biology is the study of living things. (The Greek word 'Bios' means 'life')

The two main branches of biology are zoology (animals) and botany (plants)

These two branches can then be subdivided into: ecology, genetics, biochemistry, microbiology, palaeontology, anatomy, physiology, morphology, plus many others.

The universe as we know it today is made up of **living matter** and **non-living matter**.



Characteristics of living things.

The following is a suggested list of the characteristics of living things:

- made up of cells,
- reproduce,
- grow,
- obtain and use energy,
- respond to the environment.

Other characteristics may include:

Created by Bernard Brochez

- need water,
- composed of many chemical substances and are highly organized,
- have a definite structure and size,
- have a definite life-span,
- show adaptation,
- evolve, or change, over long periods of time.

The following is a list of life processes which may be interpreted as characteristics of living organisms in some general cases:

1. nutrition,
2. transport,
3. respiration,
4. synthesis and assimilation,
5. growth,
6. excretion,
7. regulation,
8. reproduction,
9. metabolism, and
10. homeostasis.

Understand the levels of organization in biology.

The following is a list of the levels of organization studied in biology:

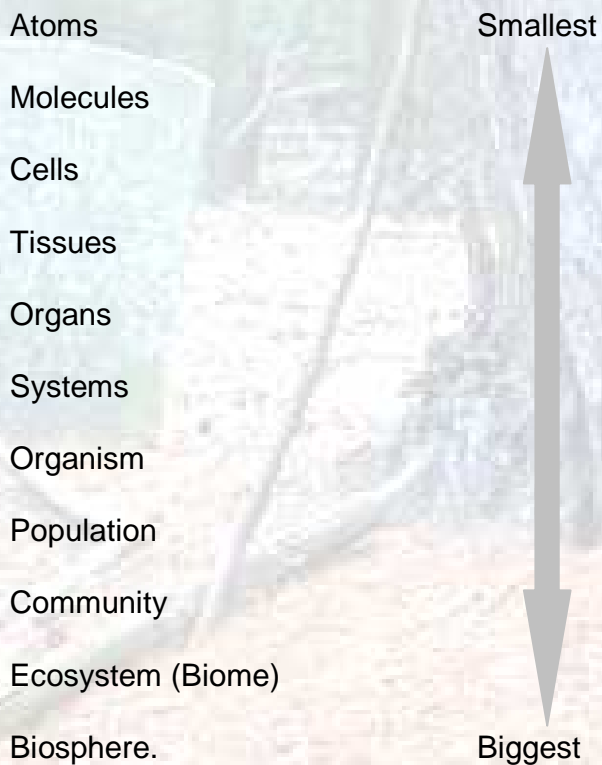

1. CELL STRUCTURE AND ORGANISATION

PLANTS

- are rooted in the soil
- AUTOTROPHIC = make their own food
- No visible sense organs
- Have chlorophyll, a green pigment.

ANIMALS

- move about
- HETEROTROPHIC = depend on other organisms for food.
- visible sense organs: eyes, ears, nose,
- No chlorophyll

1) The **plasma membrane** is the outer lining of the cell. It separates the cell from its environment and allows materials to enter and leave the cell. (In plants it lies just inside the non-living cell wall).

2. The **cytoplasm** (cyto = cell), containing water, various salts and organic molecules. The cytoplasm also contains a variety of larger structures, collectively called **organelles**, which are the working parts of the cell. Many of these "little organs" are surrounded by membranes very similar to the plasma membrane.

3. The **cell nucleus** (in bacteria, the **nuclear area**), containing the cell's genetic material (DNA and associated RNA and protein).

A. The structure of a typical cell.

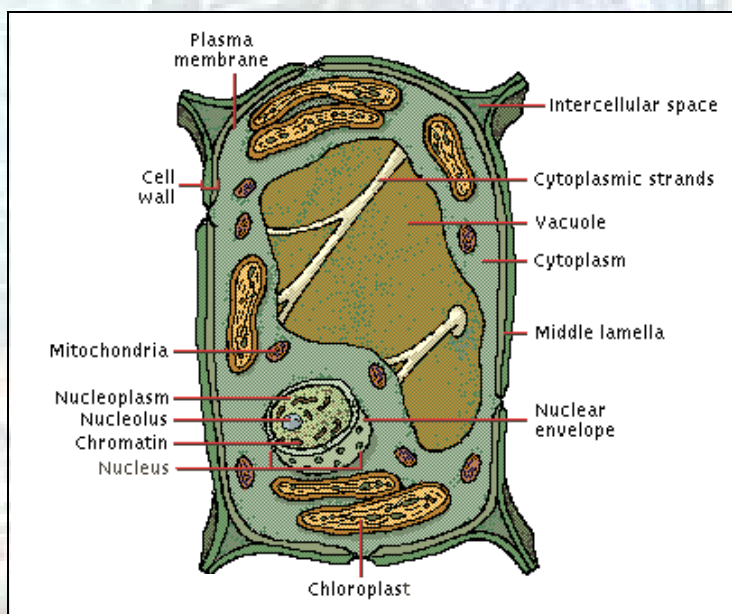

Plant cell

Fig. 1.1

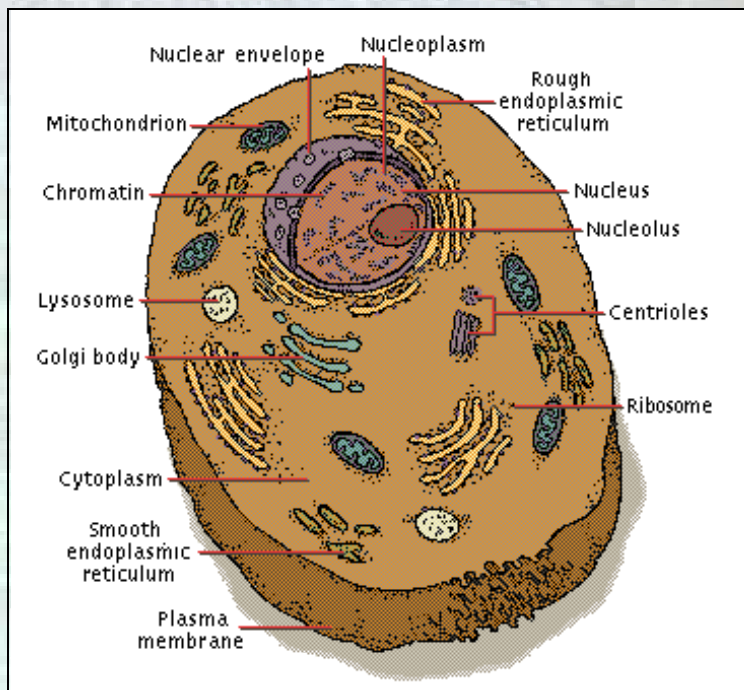

Animal cell

Fig 1.2

B. Functions of the different parts.

a) Cell membrane:

- Is the outer boundary of a cell. It acts like a screen through which all substances entering and leaving the cell must pass.
- It can grow, thus allowing the cell to expand.
- It is selectively permeable: it controls what molecules or ions should be allowed into the cell and what molecules should be kept out.
- It gives shape to the cell.

b) Cell wall (only in plant cells):

- It is made up of cellulose
- It is non-living
- It is permeable to water and gases
- When it is young it is pliable
- When it is mature it is rigid and inelastic.
- The plate between the cell walls is the middle lamella which acts as a cement layer. It is made up of pectin.

c) Nucleus:

- It is the controlling center of the cell. It contains the units of inheritance (chromosomes and genes)
- It is bounded by the nuclear membrane.

Created by Bernard Brochez

d) Cytoplasm:

- Refers to all living substances of the cell except for the nucleus.
- It contains a number of sub-units: e.g. fat globules, starch grains, vacuoles...

e) Chloroplasts (only in plant cells):

- contain chlorophyll (green pigment)
- absorb light for photosynthesis

f) Centrioles (only in animal cells):

- play an important role in cell division. (See later: Chapter Genetics - Meiosis)

g) Vacuoles:

- Are more permanent in plant cells than in animal cells.
- Contain a watery fluid: the cell sap.
- Help to maintain the internal pressure of the cell.

A cell must not be seen as being made up of independent parts, but as an internal whole functioning harmoniously.

The difference between plant and animal cells.

PLANT CELLS

- Large with definite cell wall
- Cell wall made up of cellulose
- Large vacuoles

- Chloroplasts present

ANIMAL CELLS

Smaller, no cell wall
No cellulose.
Almost entirely made up of cytoplasm.
No permanent vacuoles.
No chloroplasts.

C. Functions of some cells.

Xylem cells:

Make up the xylem tissue, which transports water from the roots up to the shoot system (stem + leaves) of a plant. Water transport should go fast. Therefore, the xylem cells die when they are mature and their cross walls break down completely to make a long narrow tube.

Muscle cells:

Make up muscles. They are elastic, so they can contract and relax. They are capable of being activated by electricity.

Created by Bernard Brochez

Red blood cells:

Are very flexible, so they can squeeze themselves through the very narrow capillaries that are part of our blood system. They can even be folded. They have hemoglobin (a protein) which binds the oxygen molecules which have entered our lungs while breathing.

Root hair cells:

Are very much adapted to take up water from the soil.

Below you see some human cells

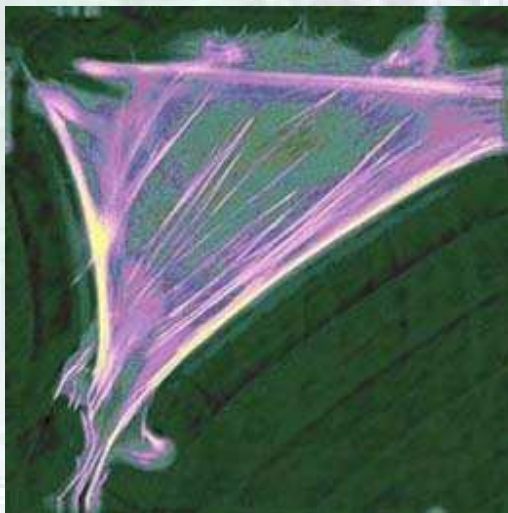

A stretched muscle cell



Red Blood Cells (RBC)

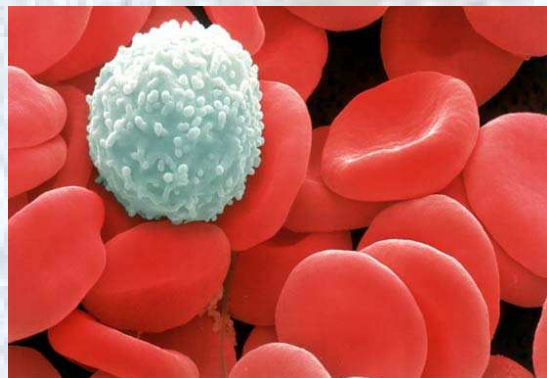

White blood cell

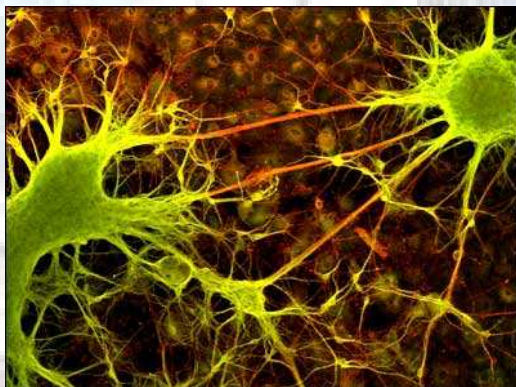

Nerve Cells

Fig 1.3

Created by Bernard Brochez

D. Tissues, organs and organ systems

Cells unite to form **tissues** which perform a particular task in an organism (animal or plant).

Examples are blood, cartilage, xylem, epidermis...

Groups of tissues get assembled in such a way that the entire structure (**organ**) performs a particular function.

Organs are functional units of the body made up of more than one type of tissue: examples are eyes, kidneys, muscles, leaves or roots.

Several organs together make up an **organ system**. The heart and blood vessels make up the circulatory system....

Exercise: If your school has microscopes available you can try and look at liver cells, onion epidermal cells
If you don't see much, ask your teacher to give you a proper stain, to make the features of the cell visible

2. DIFFUSION AND OSMOSIS.

A. Movement of molecules- Diffusion

All molecules are in constant, random motion.

SOLIDS: Molecules occupy fixed places, and each vibrates in its own space (Passengers in a crowded bus on a bumpy road). The molecules knock into each other.

LIQUID: The molecules are still quite close together and they constantly jostle one another, but they can slide past each other and so change places and go into another area.

GAS: Consists mostly of space; the scattered molecules move quickly and freely, sometimes colliding with one another.

This spontaneous movement of molecules accounts for **DIFFUSION**, the process whereby molecules of 2 or more substances move about and become evenly mixed.

e.g. a sugar cube in a beaker of water. The sugar molecules will go away from the cube and water molecules will go and take up the places where the sugar molecules were.

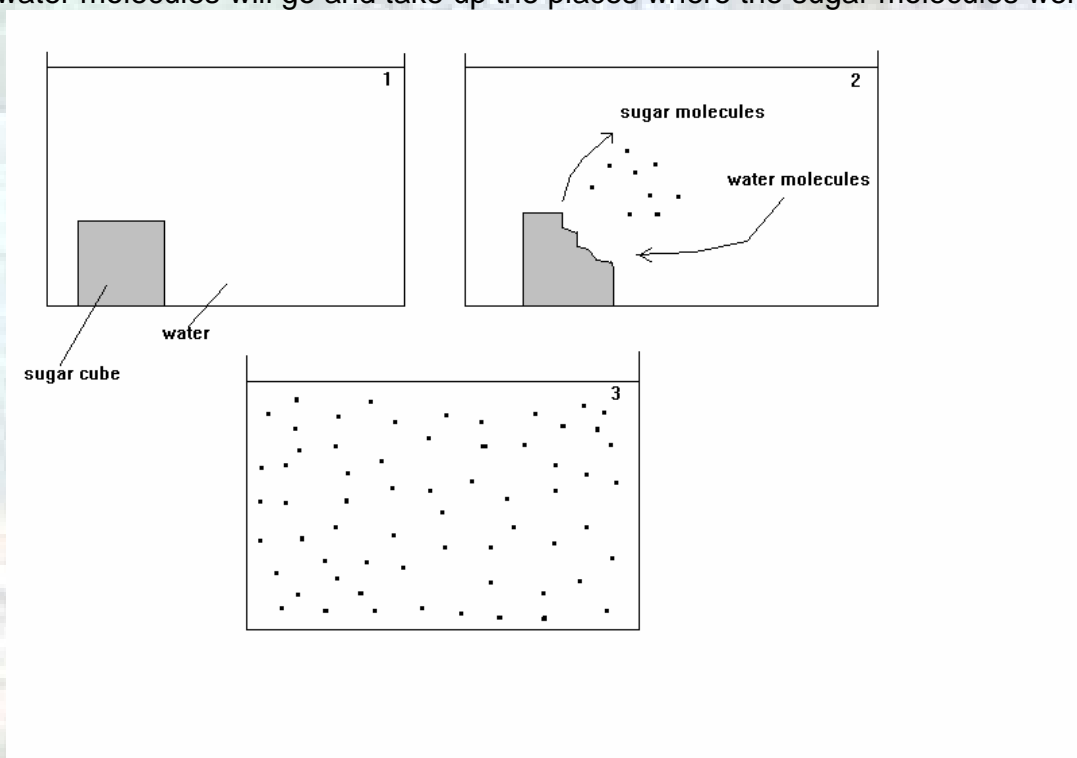

Fig 2.1

Created by Bernard Brochez

Both water and sugar show a concentration gradient. Some molecules may move back to their original place.

=====> The NET movement of each substance is DOWN its concentration gradient, into the area originally occupied by the other.

At the end, sugar- and water molecules are spread evenly throughout the solution. They continue to move randomly, maintaining this even distribution.

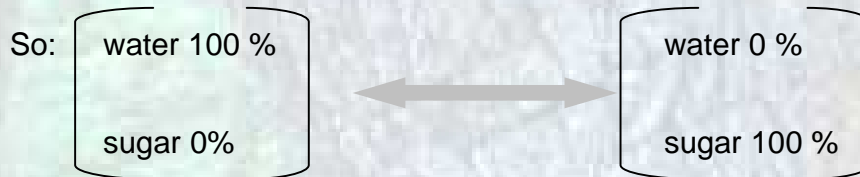

EXPERIMENT.

Take 2 test-tubes with different diameter. 100 ml. of clear gelatine is poured in both of them. A layer of blue gelatine is poured on top. Then again 100 ml. of clear gelatine is poured in them.

In tube 2, diffusion is going to go on faster since the surface area is much bigger.

$$\frac{S}{V} (1) < \frac{S}{V} (2)$$

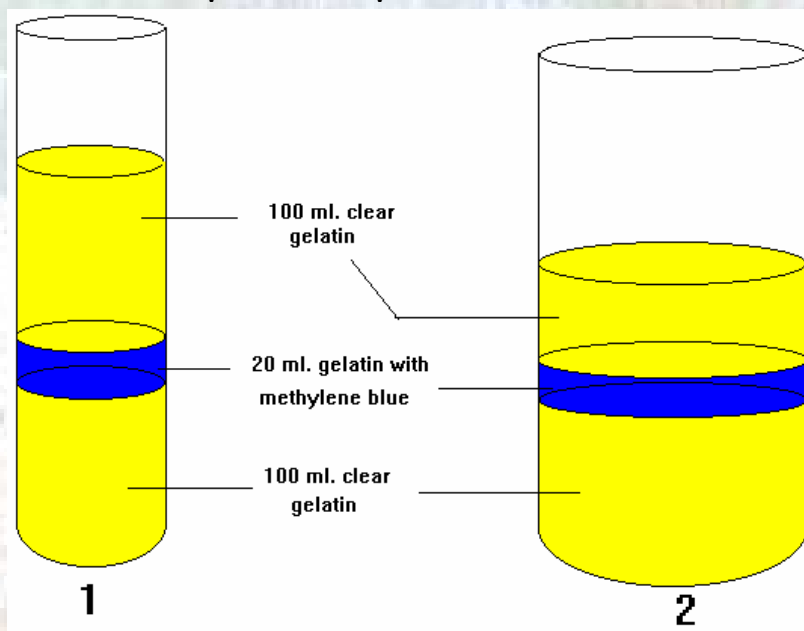

Fig 2.2

B. OSMOSIS.

Osmosis is the process by which water moves through a selectively permeable membrane. It is a special case of diffusion: it involves the diffusion of a solvent (like water), rather than the diffusion of substances dissolved in the solvent.

In osmosis in living cells, water moves across a membrane from a weak (dilute) solution into a strong (concentrated) solution.

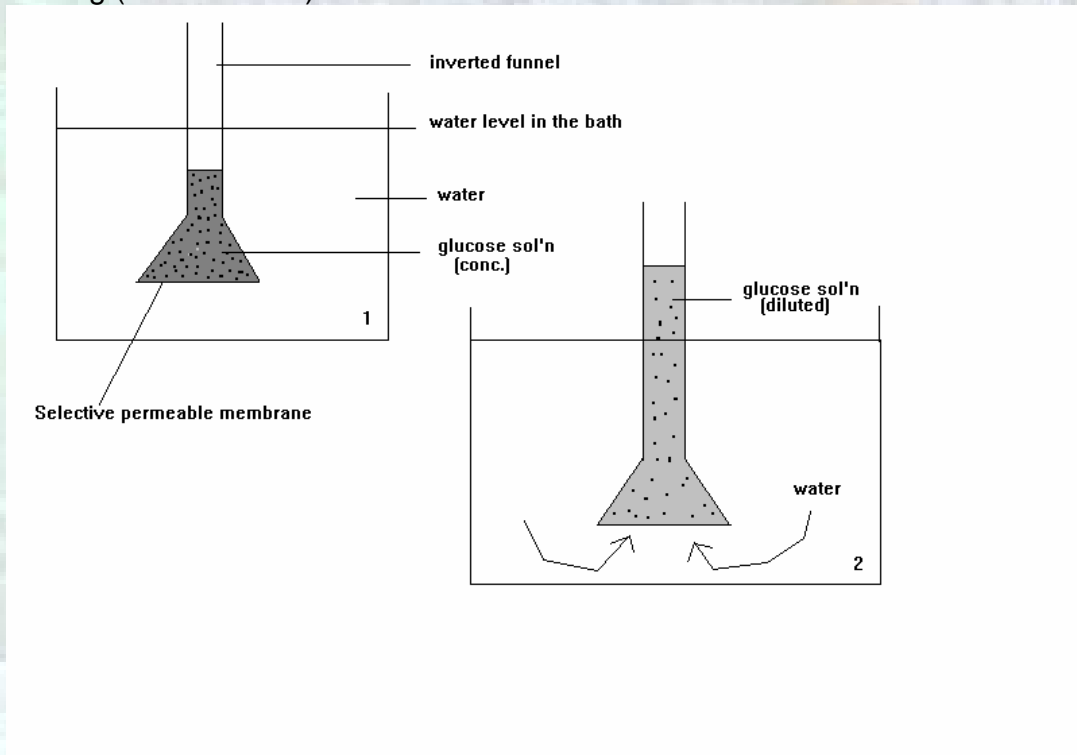

Fig 2.3

Selective permeable membrane → water can pass, glucose can not!!!

The water can move through this membrane in both directions. However, water molecules in the solution bump into the solutes and experience forces attracting them to solute particles.

→ Water moves faster in the solution than it moves out.

Water uptake by plants

An isolated plant cell surrounded by water is taking up water into the cell sap, since the cellulose cell wall is freely permeable to water and dissolved substances. The cytoplasm, however, acts as a semi-permeable membrane. The cell sap in the vacuole, since it contains dissolved salts and sugars, has an **osmotic potential** (= tendency to gain water).

Created by Bernard Brochez

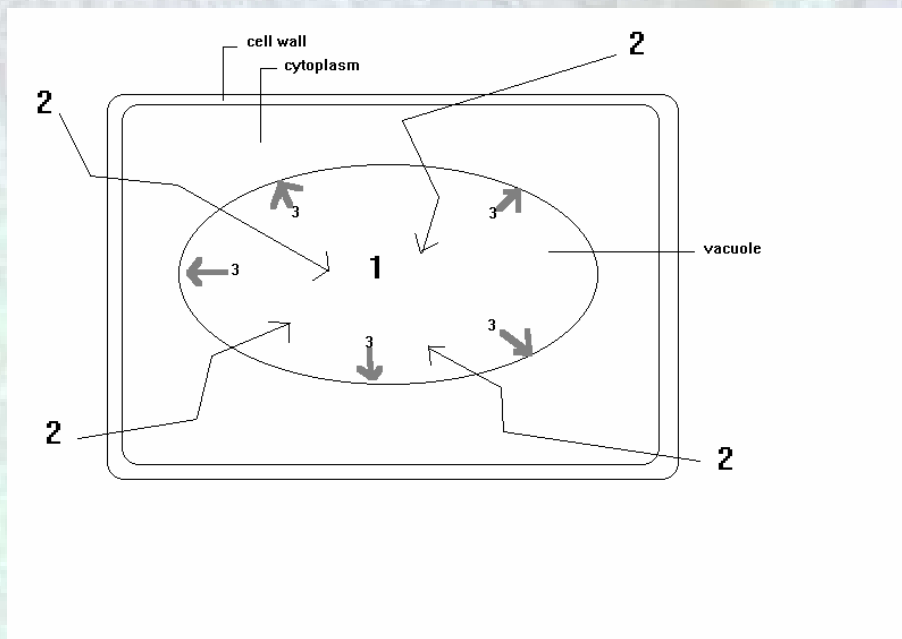

Fig. 2.4

1. dissolved salts and sugars in cell sap (vacuole).
2. Water enters by osmosis.
3. Cell sap volume increases and pushes outwards on the cell making the cell turgid.

C. Movement of water in a plant.

Water can move through neighbouring plant cells by many ways. You can read more about this in the chapter: Transport in Flowering Plants
Here, we only consider the movement of water by osmosis.

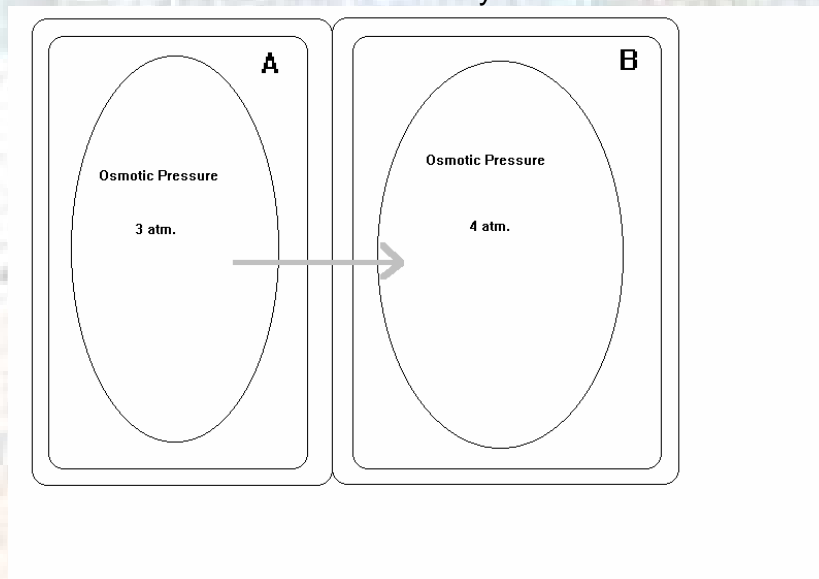

Fig. 2.5

Created by Bernard Brochez

Water moves from A \rightarrow B, since the cell sap in B is more concentrated (The osmotic pressure is higher!! See later in this chapter)

BUT: for this sort of movement it is not essential that the cell sap in B is more concentrated!

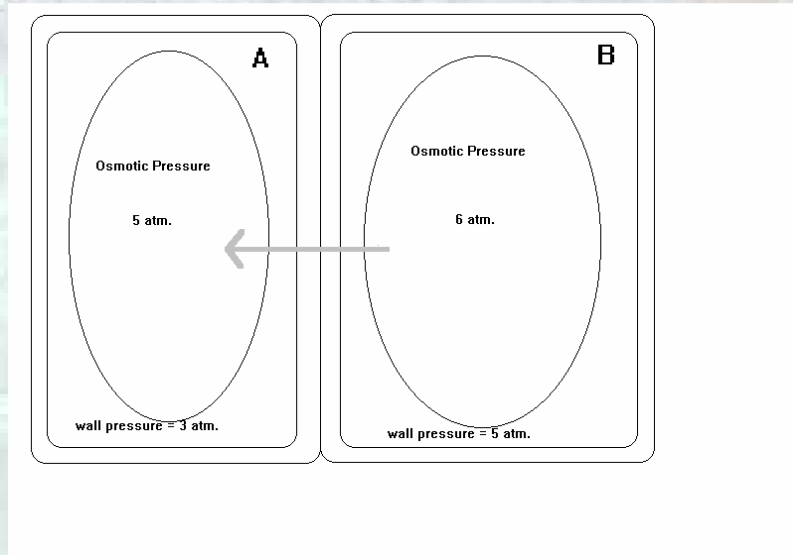

Fig 2.6

A
Water potential =
 $-5 + 3 = -2$

B
water potential =
 $-6 + 5 = -1$

Water potential = osmotic potential + inward pressure of the cell (or TURGOR pressure)

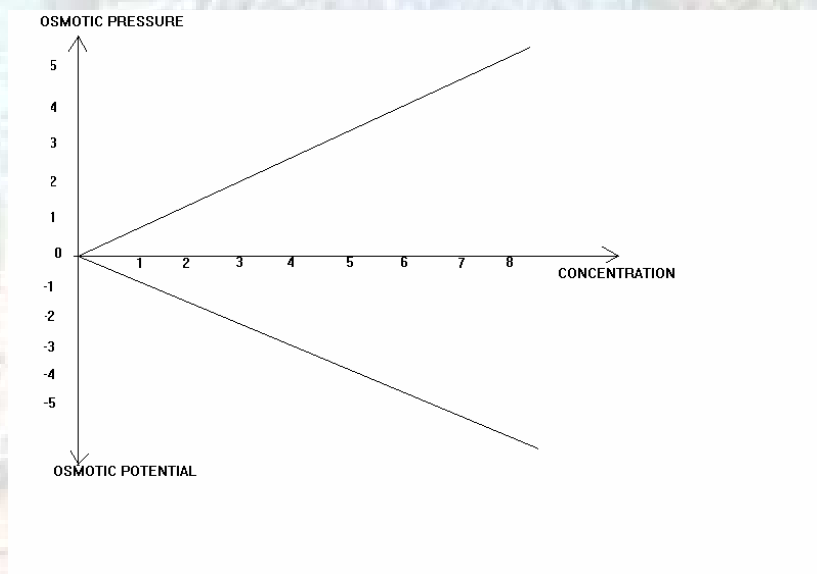

Fig 2.7

Created by Bernard Brochez

Osmotic pressure = pressure that has to be exerted on a solution to prevent it from gaining water when separated from pure water by an ideal selectively permeable membrane (it is positive).

Osmotic potential = the negative of the osmotic pressure. It is the tendency of a solution to gain water when separated from pure water by an ideal selectively permeable membrane.

Water potential = a measure of the energy of water, determined by the opposing forces of osmotic potential and turgor pressure. Pure water has the highest possible water potential, since water molecules will flow from it to any other aqueous solution, no matter how dilute it is.

So, a fully turgid cell cannot take any more water in because the osmotic potential equals the wall pressure so that the water potential = 0.

D. Osmosis and animal cells.

We put an animal cell (e.g. liver cell) in different solutions.

Isotonic solution: When the extracellular sol'n is in osmotic balance with the intracellular sol'n. No net exchange of water occurs between them.

Hypertonic solution: When the extracellular sol'n is made more concentrated than the intracellular sol'n ----> cell loses water ----> cell shrinks.

Hypotonic solution: When the extracellular sol'n is dilute enough for the cell to gain water ----> cell gets water -----> cell swells and bursts.

E. FACILITATED DIFFUSION.

Here, a carrier protein combines with a specific solute and moves it from one side of the membrane to the other side.

This process increases the membrane's permeability and so allows the substances to cross membranes faster than they otherwise would.

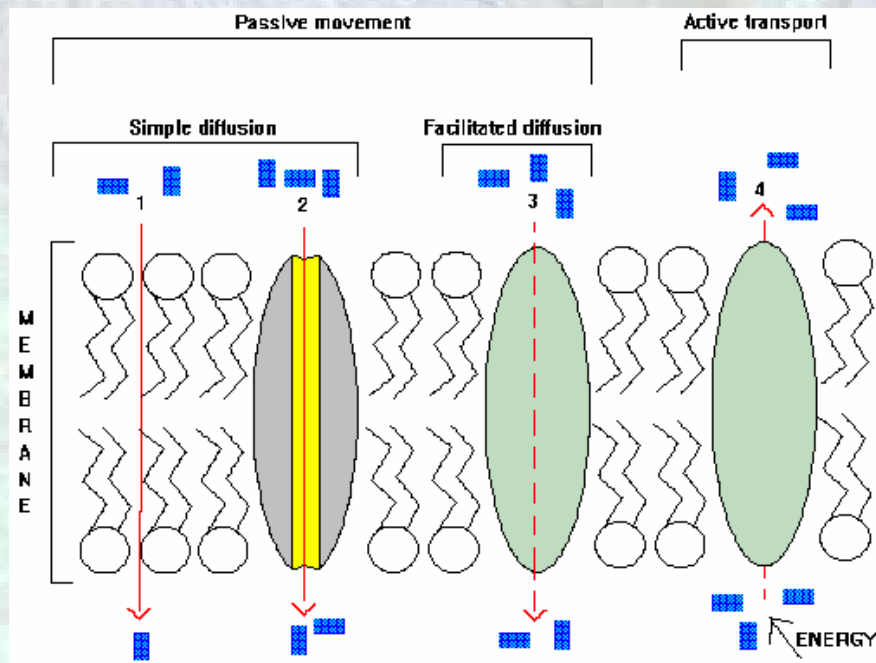
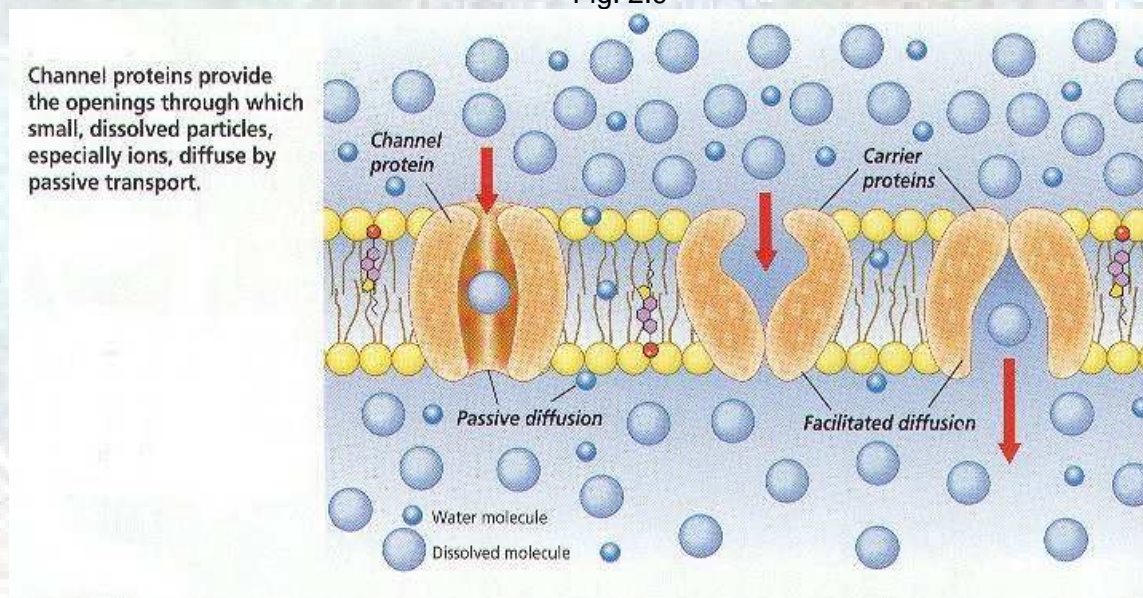

Fig. 2.8

- 1 Through lipid bi-layer
- 2 through aqueous channel in protein
- 3 Via binding to the carrier protein
- 4 Via energy and carrier protein

Fig. 2.9



E.g.

Diffusion of glucose into the cells:

In the liver and the R.B.C., facilitated diffusion moves glucose across the plasma membrane in both directions by means of a carrier protein.

Created by Bernard Brochez

The protein is more likely to pick up a G-molecule on that side of the membrane where glucose is more plentiful. If the cell is breaking down glucose quickly during respiration, the glucose conc. inside the cell falls. Glucose is then more plentiful outside the cell, and it is moved into the cell more rapidly than it is moved out.

This works in both directions. Cells in the liver for instance not only remove glucose from the bloodstream when the blood glucose level is high, but also replenish the blood glucose when its levels drop.

The structure and function of carrier proteins are still little understood, largely because these proteins are so hard to isolate from all other membrane components.

In facilitated diffusion, the transported substance must actually bind to the carrier protein involved. It is then taken to the other side of the membrane.

THEORETICAL MODEL TO EXPLAIN ACTIVE TRANSPORT.

1. Substance combines with carrier molecule

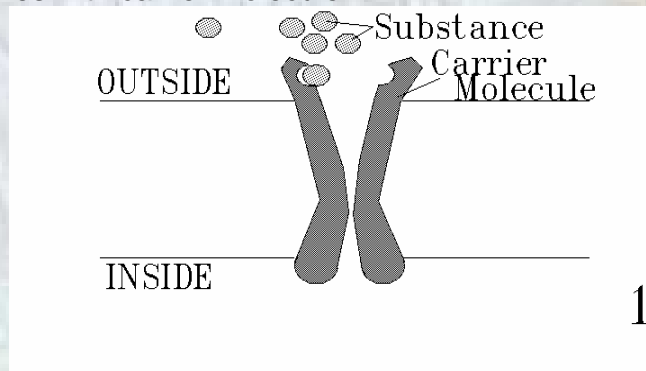

Fig 2.10

2. Carrier transports substance across membrane using energy from ATP.

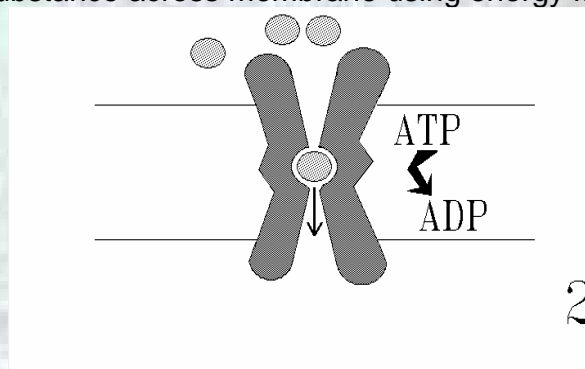

Fig 2.11

3. Substance released into cell.

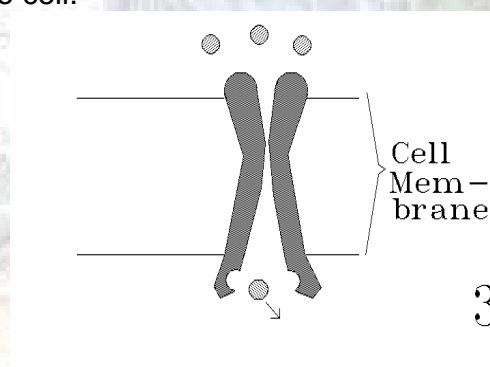

Fig 2.12

Created by Bernard Brochez

Carrier proteins are used in active transport to pick up ions or molecules from near the cell membrane, carry them across the membrane, and release them on the other side. Active transport requires energy.

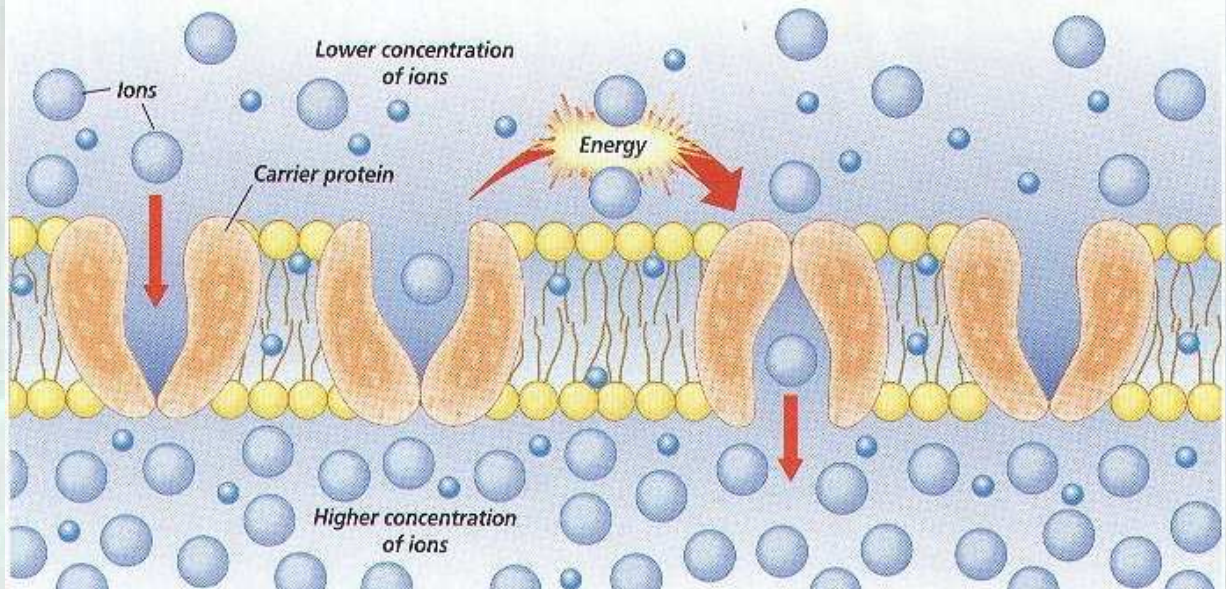

Fig. 2.13

SUMMARY

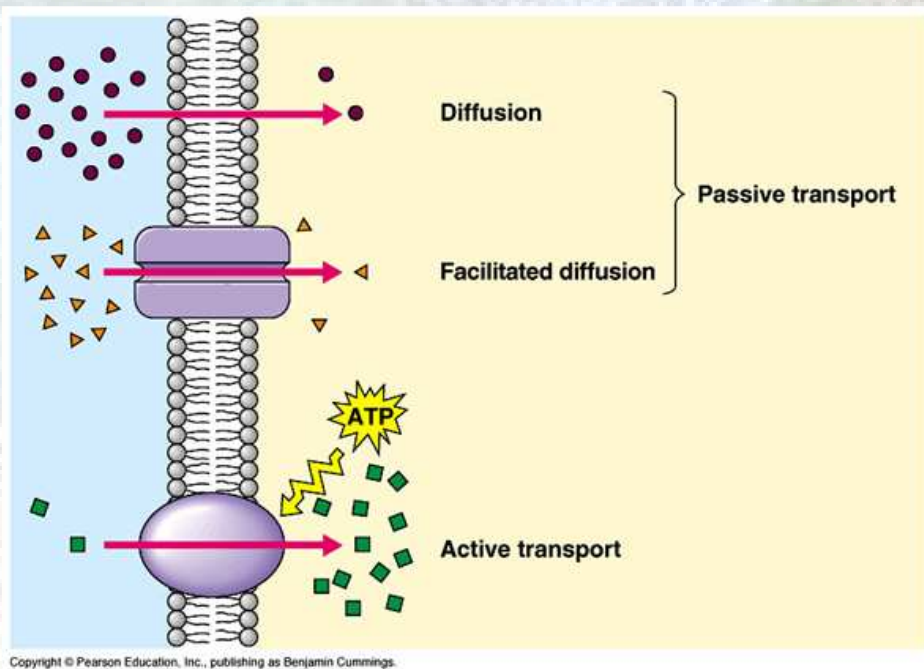

Fig. 2.14

3. ENZYMES

Enzymes are protein molecules that act as biological catalysts.

All enzymes are made up of AMINO ACIDS joined together by a peptide bond.

There are only 20 different A.A. from which an enzyme can be built up.

Amino acids contain the elements: C, H, O, N, and S.

A. General structure of an amino acid.

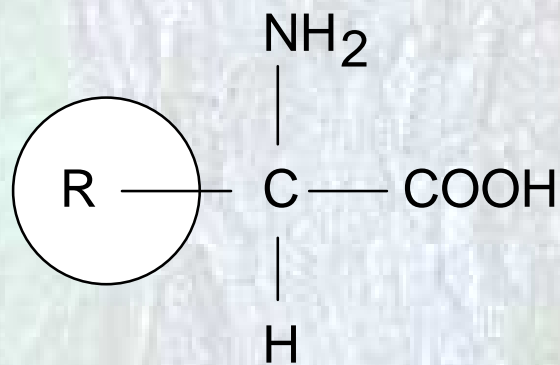

Fig. 3.1

B. Making a peptide bond.

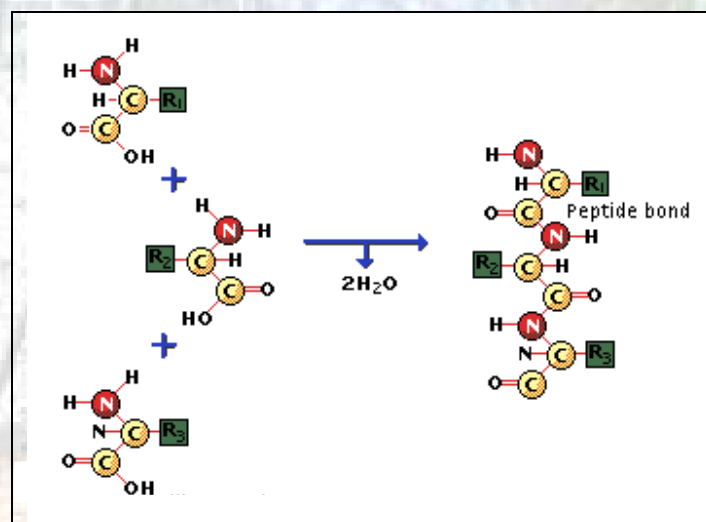
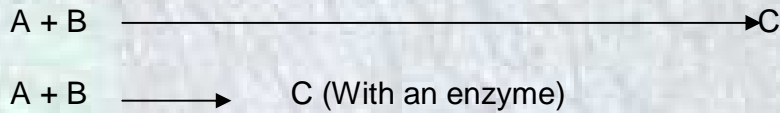

Fig 3.2

Created by Bernard Brochez

C. Properties of enzymes.

Enzymes accelerate the rate of most chemical changes in an organism without altering the end product nor themselves.



They work very rapidly: their **turn-over number** (= amount of molecules changed) is millions per minute.

They work in both directions: e.g. glucose \rightleftharpoons glycogen.

They occur in great numbers and varieties (+/- 2000).

Each enzyme has its own **substrate** (= molecule on which the enzyme works).

They are mostly named according to their substrate and the kind of reaction they catalyse (e.g. Hexokinase: changes glucose to glucose-6-phosphate).

The names mostly end on -ase.

e.g. Salivary amylase
peptidase

E.g. Hydrolysis of urea from a cat's urine into CO₂ and NH₃, which gives its characteristic odour to a litter box in need of cleaning.

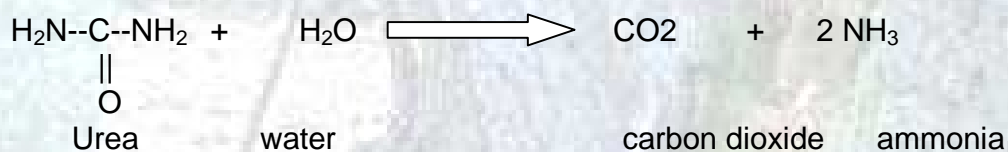

This reaction is catalysed by urease, an enzyme produced by bacteria that settle out of the air and reproduce in the litter box.

At room temperature and pH 8: 1 molecule of urease catalyses the hydrolysis of 30,000 molecules / second. Without a catalyst this reaction would take about 3 million years. This means that the enzyme increases the speed trillion times.

Some enzymes work even faster than urease, others slower.

Created by Bernard Brochez

D. Enzyme- substrate complexes.

Enzymes work very specific. This specificity occurs because an enzyme actually binds with its substrate(s) to form an Enzyme substrate complex (E-S complex). The substrate binds specifically to a cluster of chemical groupings known as the enzyme's active site.

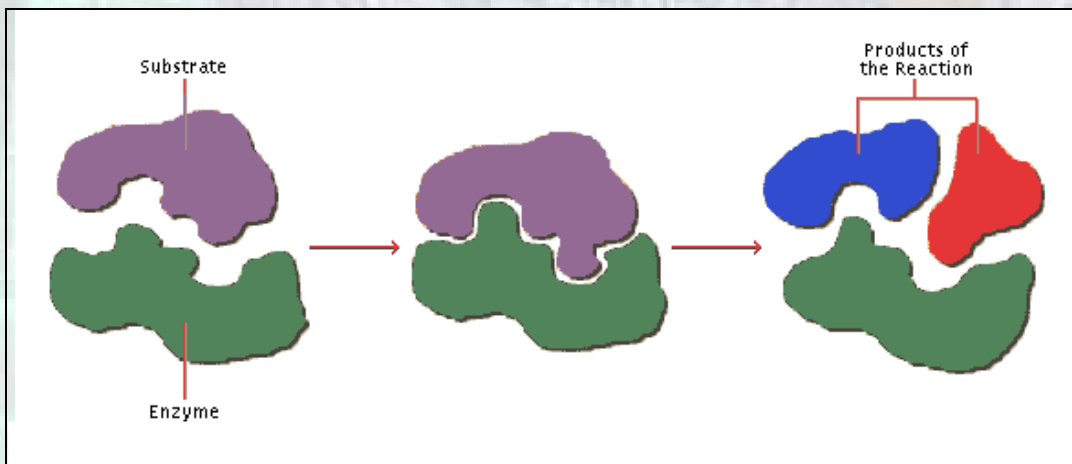

E-S Complex
Fig 3.3

E. Effect of pH on the enzyme's activity.

pH = a measure of how acidic or basic a solution is on a scale of 0 to 14 (0 = very acidic, 14 = very basic, 7 = neutral).

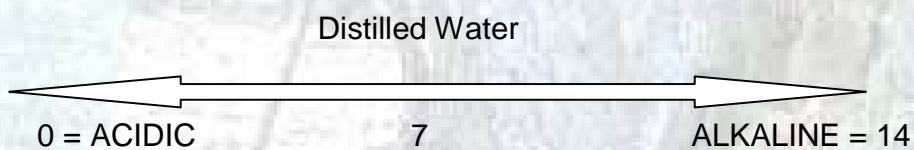

Every enzyme has its **optimum pH** (= pH where it works best). Most enzymes work in almost neutral media. Some however work in acid (e.g. Stomach) or alkaline media.

Many of the R- groups of an enzyme ionise when they are dissolved in water, so the enzyme will become electrically charged. The pH of a solution will therefore determine the charges that an enzyme bears.

e.g. In acid condition: The negatively charged R- groups on the enzyme will tend to combine with the positive H- ions in the solution. Thus neutralised, the originally

Created by Bernard Brochez

negative R-groups can no longer bind to positively charged groups of the substrate. Only if an enzyme bears the right charged groups at its active site will it react with its substrate.

F. Effect of temperature on enzyme's activity.

When the temperature increases, molecules tend to move faster, collide harder and more often, so it would be logical to say that the rate of reaction should also increase. HOWEVER: Proteins become denatured when temp. increases: their 3- dimensional structure is being destroyed. So the enzymes can no longer function.

- Heating preserves food since it destroys the enzymes of organisms that cause decay.
- Refrigeration preserves food since it slows down the enzyme's activity of organisms that cause decay, or from enzymes present in the food.

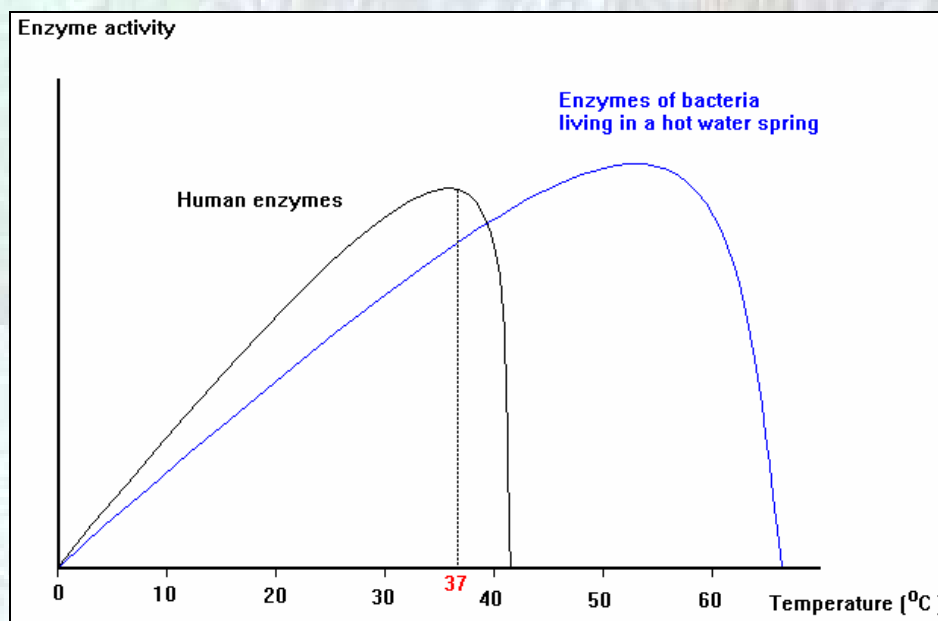

Fig. 3.4

It is obvious that human enzymes will work best at a temperature of 37 degrees Celsius. If you get fever, you don't feel very much O.K., and you also don't feel very hungry. All this happens because your temperature is too high, and so your enzymes and hormones (protein in nature) don't function well.

Not all enzymes get denatured at 40 degrees Celsius. Biologists have discovered bacteria living in hot water geysers where the temperature might even reach 70 degrees.

G. Enzyme activity in germination of seeds.

In order to germinate or begin growing into a new plant, seeds must be supplied with water. However, the seed coat is often so thick or impermeable that it cannot absorb water. First the seed coat may need to be partially digested by animals or decomposing organisms (enzymes will work on the seed coat).

The embryo secretes **GIBBERELLIN** (a plant hormone) which induces the **ALEURONE** (= tissue layer between the seed coat and endosperm) to secrete a variety of enzymes. These enzymes break down starch and other stored food in the endosperm, making it available for absorption by the developing embryo.

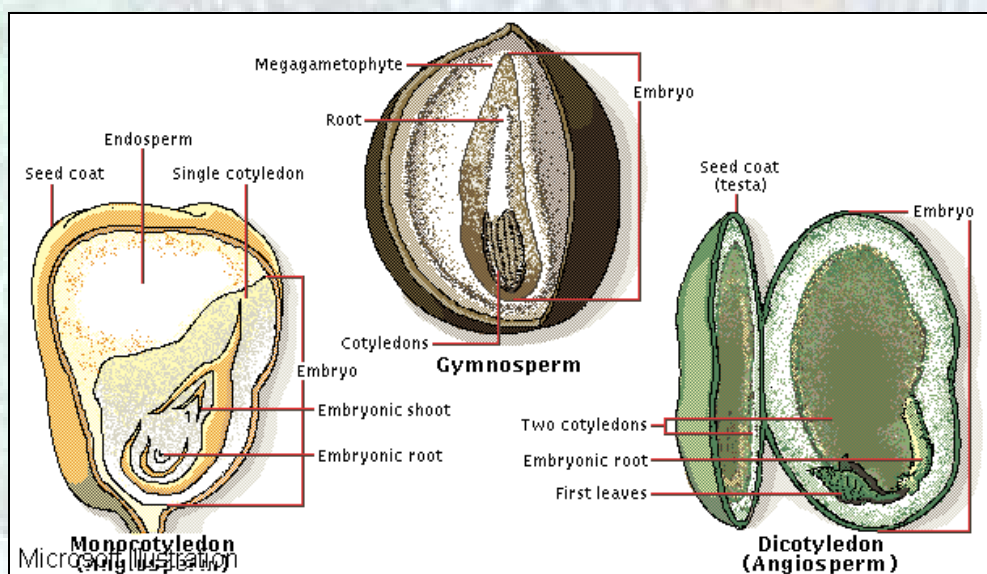

Fig. 3.5

4. NUTRITION IN GREEN PLANTS. PHOTOSYNTHESIS

The basic difference between animals and plants lies in the methods in which they obtain their food.

- Animals obtain their life chemicals such as proteins, fats, carbohydrates by eating plants or other animals.
- Plants are able to make their own life chemicals from CO₂, H₂O and chlorophyll using light energy.

All life therefore depends on the compounds made by plants. They use solar energy, so the entire world of living things depends on solar energy for its continued existence. All food chains depend on the process of photosynthesis:



The carbohydrates in plants which are formed (glucose) have more energy than the starting materials CO₂ and H₂O. The **energy-poor** compounds CO₂ and H₂O are converted into **energy-rich** compounds: carbohydrates.

Photosynthesis therefore converts radiant Energy from the sun into chemical energy in plant tissue.

Green plants have the structural adaptations necessary for trapping light and immediately the light Energy is converted into chemical energy.

A. Structure of the leaves in relation to photosynthesis.

Photosynthesis takes place mainly in green leaves, but it also takes place in ANY green part of the plant. The manner in which the leaf is structured reflects this purpose as can be seen in the diagram:

- The large leaf blade is attached to the stem at right angles, so the maximum surface is exposed to the sun.
- The palisade layer is rich in chloroplasts which line the walls of the cells. The chloroplasts can move to the top of the cells to receive more light.
- The spongy mesophyll layer contains large air spaces which allow the carbon-dioxide to diffuse rapidly to the palisade cells.

Created by Bernard Brochez

- The leaf has a large number of stomata on the lower side, allowing the maximum inward diffusion of carbon-dioxide and at the same time the outward diffusion of oxygen.
- The large number of leaves gives the plant a large external surface area, thus exposing the plant to a large catchment area of CO₂ and light.

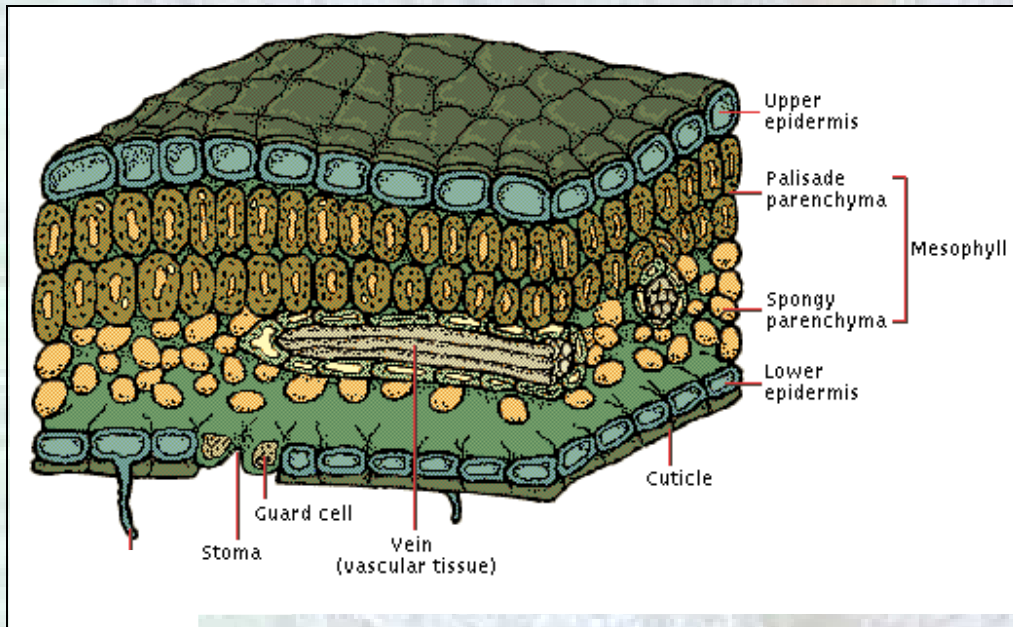

Fig. 4.1

- Because the leaf is thin, no cell is far removed from the outside atmosphere, nor is any cell more than 5 or 6 cells away from a vein ending. Communication between mesophyll cells and veins by diffusion is therefore easy. Water and salts move easily from xylem tubes to the cells, and synthesised food from the cells to the phloem tubes.
- The leaf is covered on both sides by a waxy non-cellular layer: the cuticle, the function of which is to prevent excessive loss of water.

B. Importance of Photosynthesis.

- Plants produce carbohydrates; the basic product from which more complex food substances, such as proteins and fats are made.
- Oxygen is liberated into the air during the process and this helps to keep the level of oxygen at 20 %, which is a very suitable level for plants and animals.
- By absorbing carbon-dioxide from the atmosphere, photo-synthesis maintains a suitable balance of around 0.03 %. Higher values of this poisonous gas would be lethal to living things.
- Various products such as wood, coal, oils and drugs... could not be produced without photosynthesis.

C. Stomata.

Are very numerous on the lower epidermis. On the upper side of the leaf they are fewer. Usually the stomata are open during the day and closed during night-time. Examining their structure may help understand this.

A stoma consists of a pore which is bound on both sides by a kidney-shaped guard cell. The guard cells contain chloroplasts while the other epidermal cells don't. The inner wall of each guard cell is thicker than the outer wall.

Opening and closing of stomata.

When a guard cell becomes TURGID (this means that the internal pressure or TURGOR increases), by the intake of water (see osmosis), its outer wall is pushed outwards and the thick inner wall bulges in the same direction. As both guard cells work in the same way, but opposite directions, the pore opens.

(Do an experiment with a balloon which, on one side, has cello-tape).

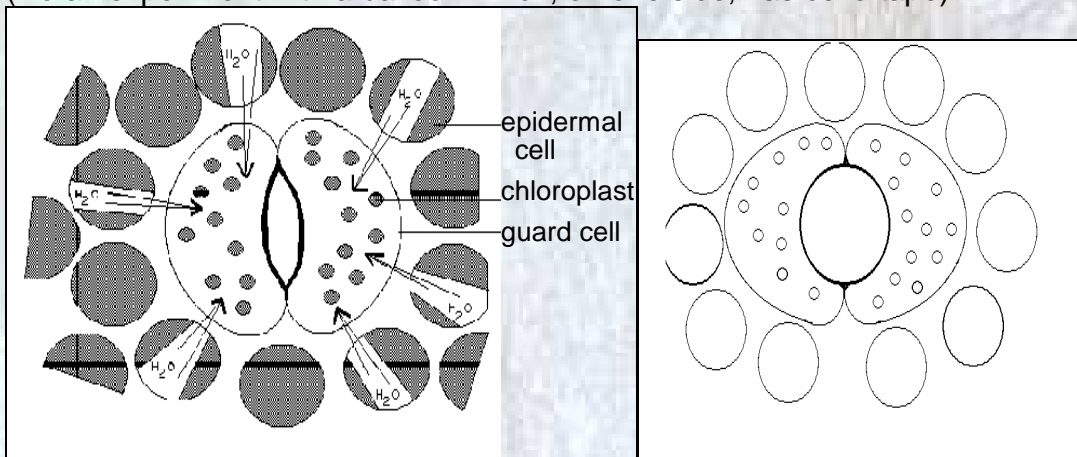

Fig. 4.2

DAYTIME:

- Photosynthesis is carried out in the chloroplasts of the guard cells.
- Sugar is made and this sugar dissolves in the water of these cells.
- The osmotic pressure increases (see later in osmosis).
- As a result, water moves from the epidermal cells (no chloroplasts) into the guard cells.
- The guard cells become turgid and the pore opens.

NIGHT-TIME:

- When darkness falls, photosynthesis stops, while respiration continues.
- CO_2 is produced and this dissolves becoming carbonic acid.

Created by Bernard Brochez

- The acidity degree increases (pH goes down)
- Because of this higher acidity degree, enzymes are now able to change the sugar into starch, which is insoluble and comes out of solution.
- The water in the cells becomes pure and the osmotic pressure drops.
- Some water moves out of the guard cells and the turgor pressure drops.
- The pore will now close.

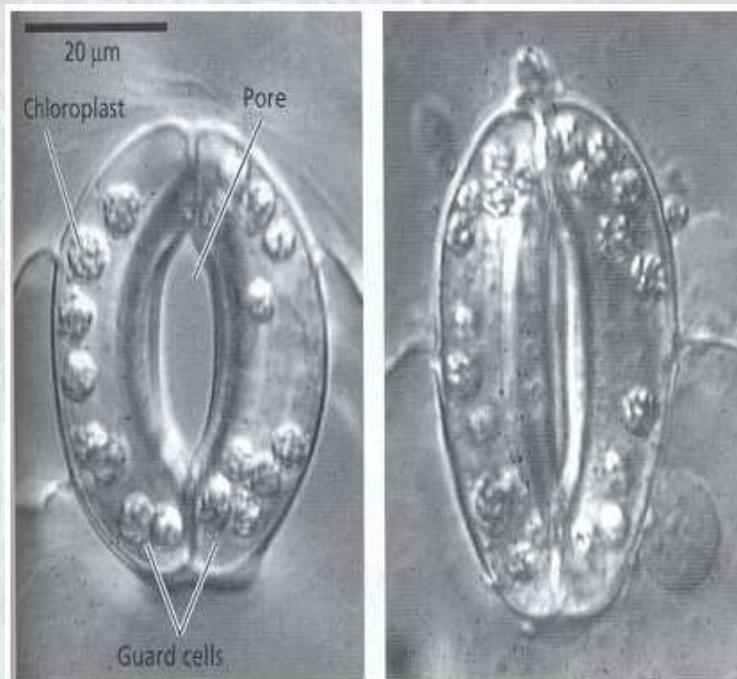

Fig. 4.3

D. Factors necessary for photosynthesis.

CO₂, H₂O, Chlorophyll, Sunlight/light.

In addition to these 4 factors, other factors such as suitable temp. and enzymes are equally important for the chemical process of photosynthesis to take place.

Some of these factors can be limiting or inhibiting to the process:

LIMITING FACTOR: is a factor, which by increasing its quantity brings about a direct increase in the rate of the process. (e.g. CO₂, temperature...).

INHIBITING FACTOR: is a factor, which by increasing its quantity brings about a decrease in the rate of the process. (E.g. temp; gets too high).

OPTIMUM CONDITION: is when a factor is present to such a degree that it allows the process to proceed at maximum rate.

D- 1. CARBON DIOXIDE.

Experiment: to show the necessity of CO_2

Take two beakers A and B. In A we put fresh tap water and pond weed. In B we put previously boiled, cooled tap water which has not been re-exposed to the air. We put pond weed and cover the water surface with a thin layer of oil. We put the two beakers in the sun.

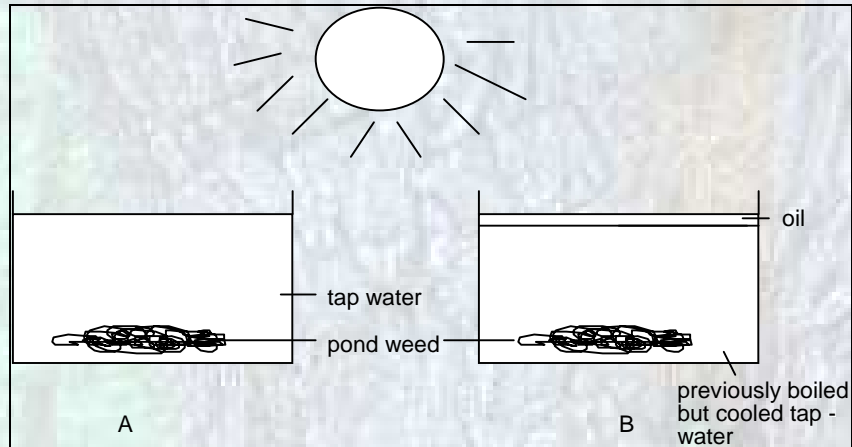

Fig. 4.4

Observation: Streams of bubbles (O_2) will be seen to rise in A and not in B.

Conclusion: In the absence of CO_2 , a plant does not produce oxygen and we can conclude that no photosynthesis occurred.

Another way to test the necessity of CO_2 is as follows:

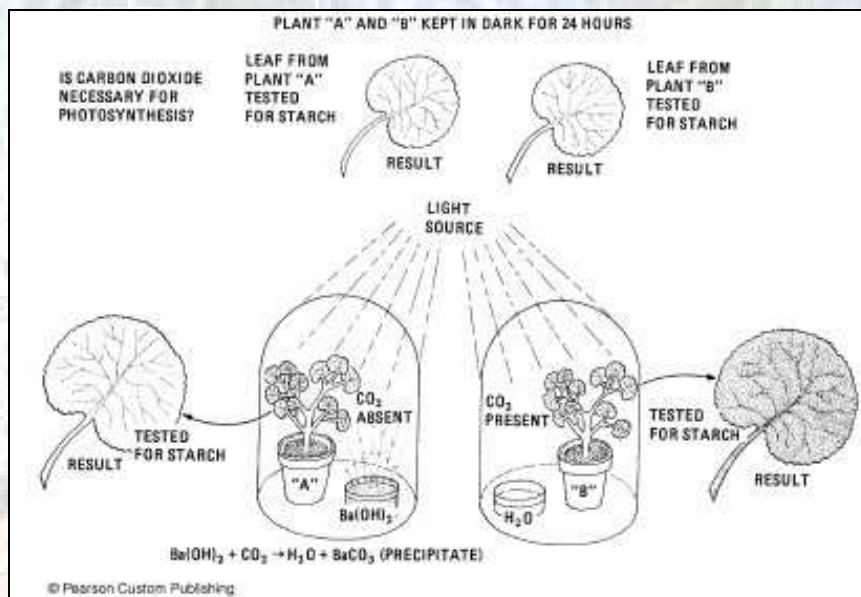

Fig. 4.5

Created by Bernard Brochez

D- 2. WATER.

Water is very important in any biological process. No water: no life!!!!

The veins with their numerous, tiny branches are continuous with the vascular bundles of stem and roots. The bundles also penetrate the leaves, so the xylem vessels are able to carry water right up to the cells. Only a small portion of the water reaching the leaves is used in photosynthesis, as most of it passes out through the stomata during transpiration.

Transpiration is necessary because:

- The temp. of the leaves has to be kept below a certain level.
- Together with the water, mineral salts are carried towards the leaves. Those salts are needed for growth.

D- 3. CHLOROPHYLL.

A pigment found in the chloroplasts. It is a complex molecule made up of carbon, nitrogen, hydrogen and a small amount of magnesium. There are two kinds of chlorophyll: Chl.a (blue-green) and Chl. b (yellow-green).

Experiment: *To show that chlorophyll is necessary.*

Take a potted plant with variegated leaves and put it in a dark room for about 48 hrs. to destarch it. (The plant does not do photosynthesis and uses the starch, made the previous days). Then put the plant in direct sunlight for 6-8 hrs. Detach one of the leaves and make a drawing of it, clearly indicating the zones of different colours. Then test this leaf for the presence of starch.

To test for the presence of starch.

1. Dip the leaf in boiling water for 5'. This kills the protoplasm by destroying the enzymes in it. There will be no further chemical reactions. It also makes the leaf more permeable to iodine solution.
2. The leaf is then put in a test-tube containing methylated spirit, and boiled using a water bath until all the chlorophyll has dissolved out. The leaf becomes white so the colour changes caused by interaction of starch and iodine are easier to be seen.
3. Alcohol makes the leaf brittle and hard, but it can be softened again by dipping it once more into boiling water.
4. Spread the leaf flat on a white surface.
5. Spread some drops of iodine on the leaf

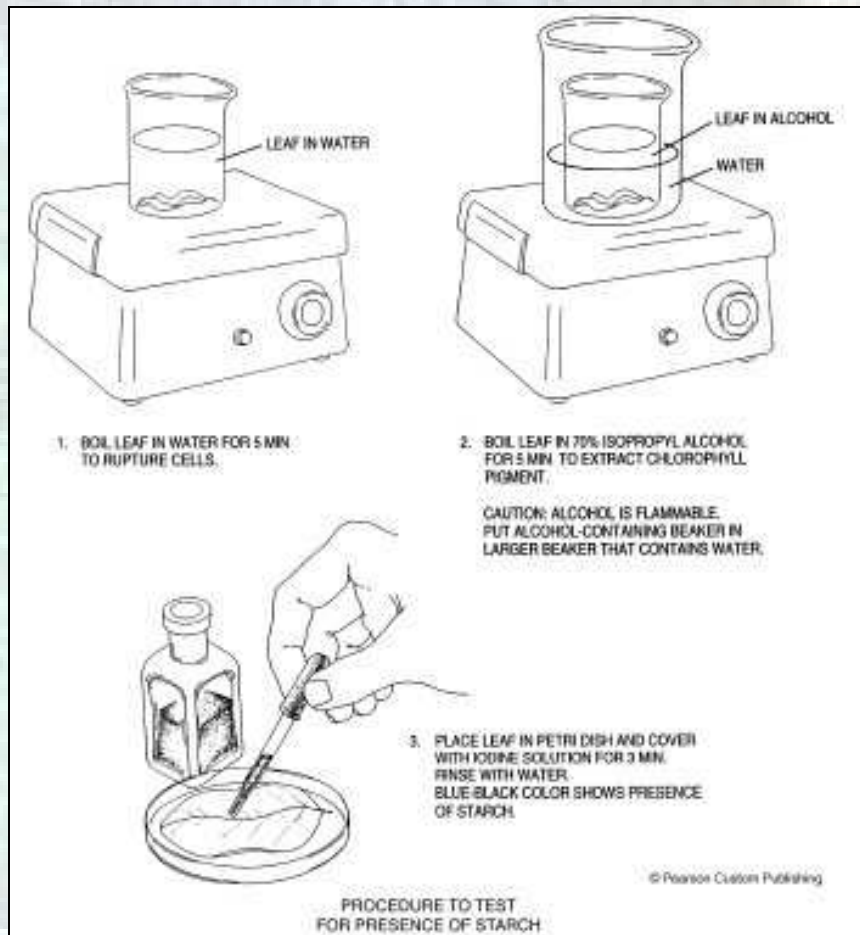

Fig. 4.6

Observation: Parts of the leaf which have starch will turn blue-black. Parts which have no starch will be orange-brown, which is the colour of the iodine. Compare the tested leaf with your drawing. Blue-black zones should be the zones which you indicated as green.

Conclusion: Chlorophyll is necessary for photosynthesis.

Experiment: *Separation of chlorophyll pigment by paper chromatography.*

1. Extract the chlorophyll as in the experiment above, i.e. by boiling a leaf in alcohol.
2. Place a drop of the chlorophyll extract at the centre of the filter paper near the end (2 cm from the bottom). Allow the drop to dry and repeat this 10 times.
3. Pour some solvent (equal parts of acetone and petroleum-ether mixed) into a large test-tube to a depth of 1.5 cm.)
4. Suspend the filter-paper as shown.

Created by Bernard Brochez

After some time you can observe the sequence in which the colours separate out.

Pigment	Colour
Carotene	yellow
Phaeophytin	yellow- grey
xanthophyll	yellow-brown
chl a	blue-green
Chl b	yellow-green

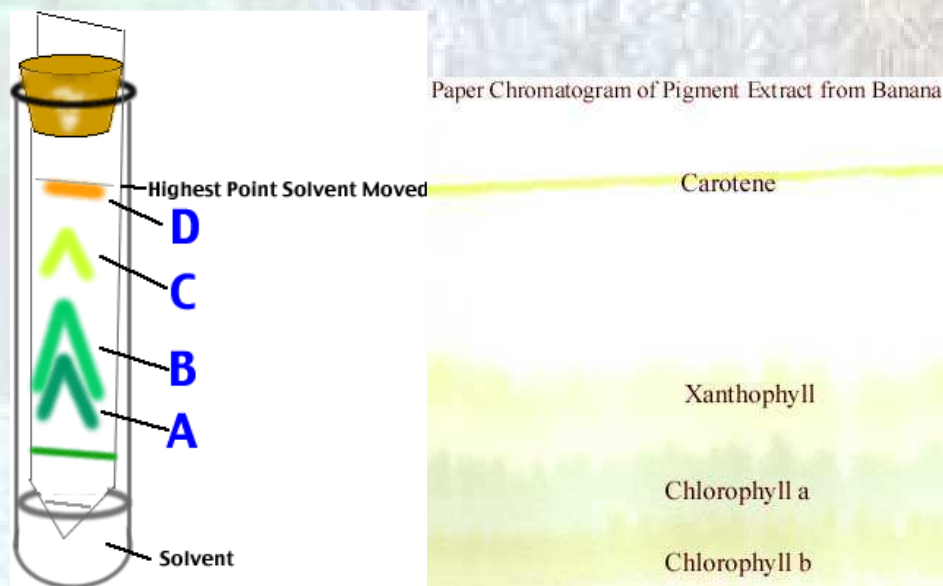

Fig. 4.7

Fig. 4.8

D- 4. LIGHT.

Two conditions of light have to be considered: light intensity and wavelength of light.

1. LIGHT INTENSITY.

- When no other factor is limiting the rate of photosynthesis increases with an increase in light intensity.

Created by Bernard Brochez

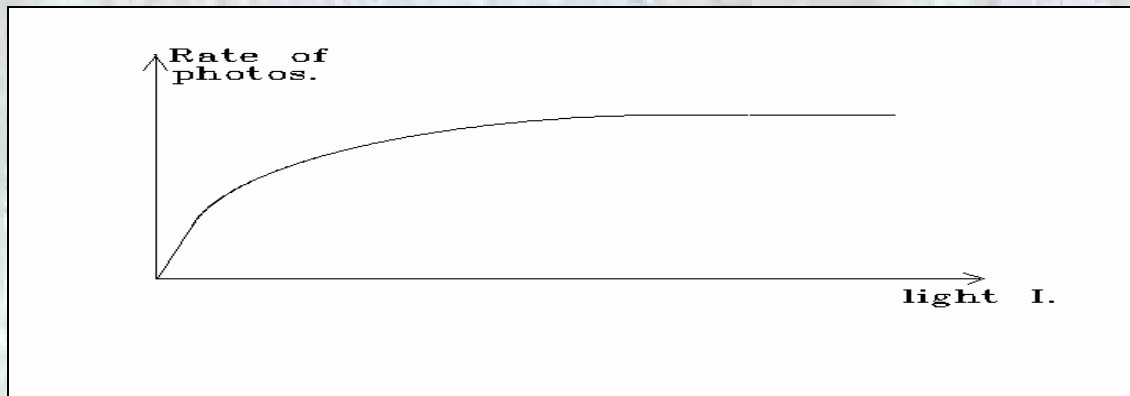

4.9

Fig.

- CO₂ can be a limiting factor !!!!

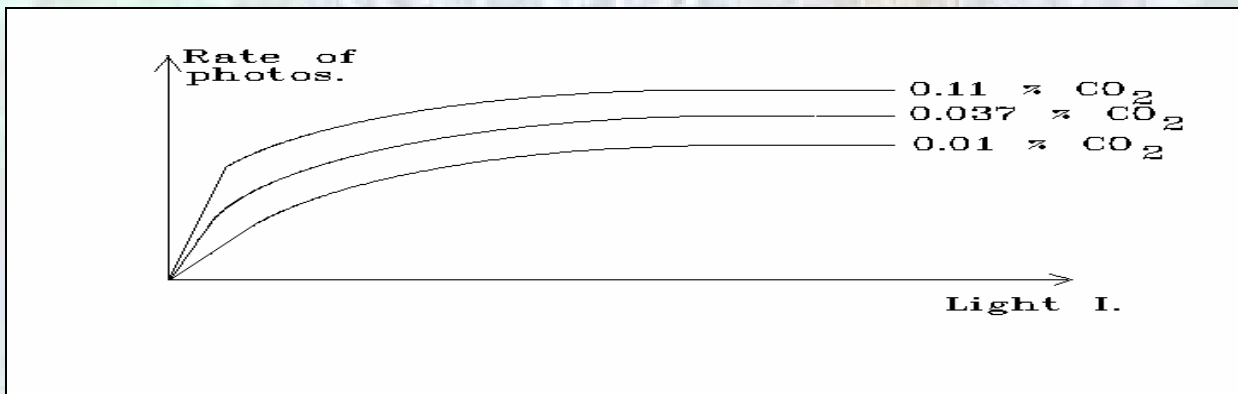
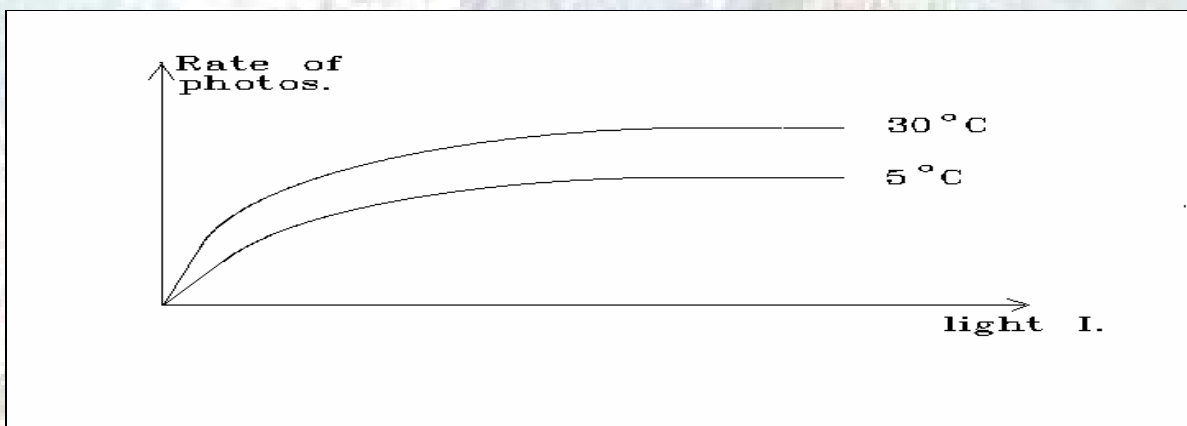

Fig. 4.10

Increasing the light intensity increases the rate of photosynthesis only up to the point when the plant can almost absorb CO₂ no faster. The stomata are now completely open.

- Temperature can be a limiting factor !!!

Fig. 4.11



The effect of temperature on the rate of photosynthesis at different intensities of light.

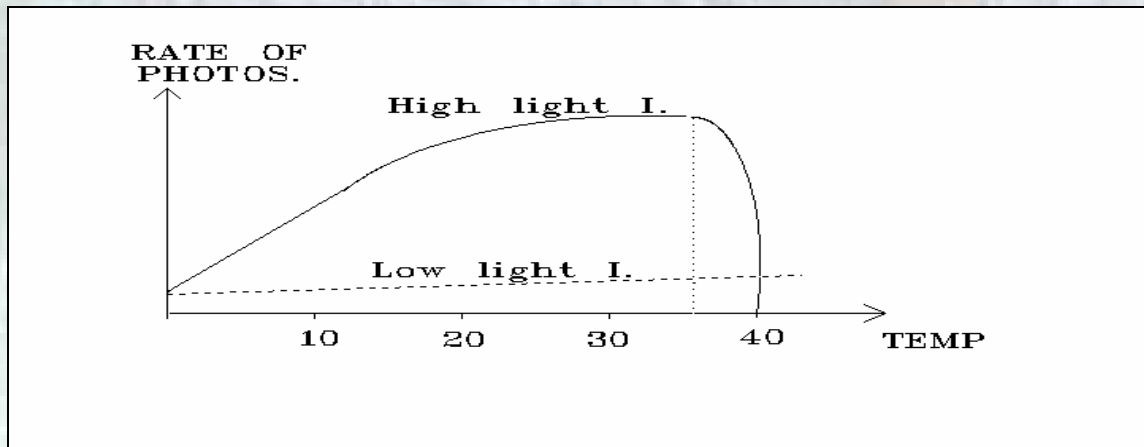

Fig.

4.12

- At low temp.: The chemical reactions need a certain temperature before they reach the max. rate. As photosynthesis is a chemical reaction, the rate will be rather low at low temperature.
- At moderate temp.: the rate of photosynthesis is higher because molecules move and react faster. An increase in temp. brings about a direct increase in the rate of photosynthesis (temperature = limiting factor).
- At high temp.: Enzymes which are involved in photosynthesis can be denatured (destroyed). This eventually stops all biochemical reactions (temp = inhibiting factor).

2. WAVELENGTH OF LIGHT.

Photosynthesis can only take place when the light supplied lies within the visible spectrum. Infrared and ultraviolet are not used. The most useful wavelengths are the red-orange band (600-700 nm.) and the blue-violet band (400 nm.) (1nm. = 10⁻⁹ m.) An instrument can be used to measure the absorption of light by chlorophyll for each wavelength and a graph can be plotted. The resulting curve is called the absorption-spectrum.

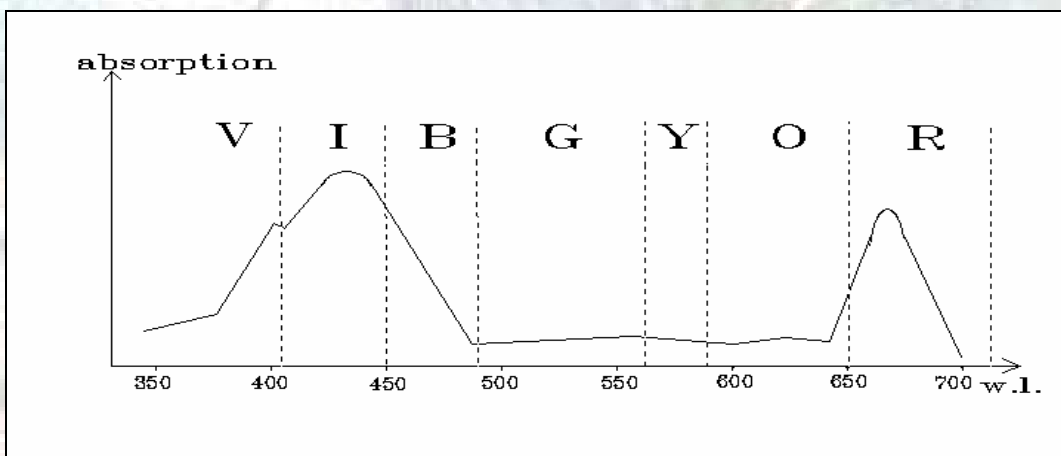

Fig. 4.13

Created by Bernard Brochez

Note that some of the yellow and orange wavelengths are also absorbed. Only GREEN is completely reflected and this explains why the leaves appear green in colour.

Chloroplasts can move about in the cells. They go to rearrange themselves in a particular way at a certain light intensity.

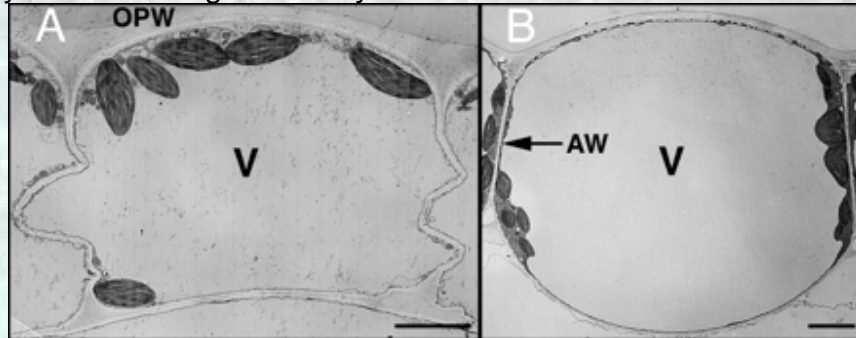

Fig. 4.14

Photo-orientation movement of chloroplasts in the aquatic angiosperm *Vallisneria gigantea* epidermal cells. Cross-sections of leaf epidermal cells, in which chloroplasts accumulated along the outer periclinal wall (OPW) under dim light (A) or along the anticlinal walls (AW) under strong light (B). V, central vacuole.

EXPERIMENT:

To measure the rate of photosynthesis against the different wavelengths.

Material: pond weed, lightfilters of different colours, 100 W. bulb, water bath, bottomless flask.

Allow time for the bubbling to become regular before counting the bubbles (oxygen). Count for about 10 minutes.

Replace the pond weed every time a new filter is used. Count as before.

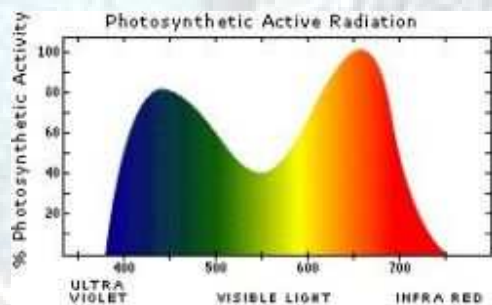

Fig. 4.15

The rate of bubbling indicates the rate of photosynthesis for the various wavelengths used. When you plot your results, you will have a graph resembling the one above.

EXPERIMENT: *to prove that light is necessary for photosynthesis.*

You cut out a simple shape from a piece of aluminum foil to make a stencil (e.g. your initial). The stencil is attached to a previously destarched leaf. After exposure to 6-8 hrs of daylight, the leaf is detached and tested for starch.

Observation: only parts of the leaf which were exposed to the sunlight will turn blue-black when reacting with iodine.

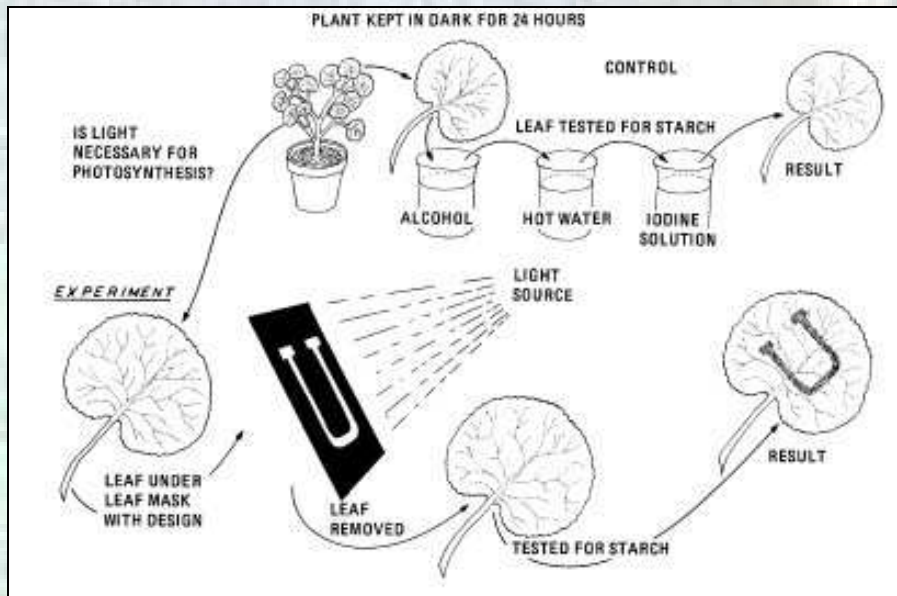

Fig. 4.16

EXPERIMENT:

To show that carbon-dioxide is used during photosynthesis.

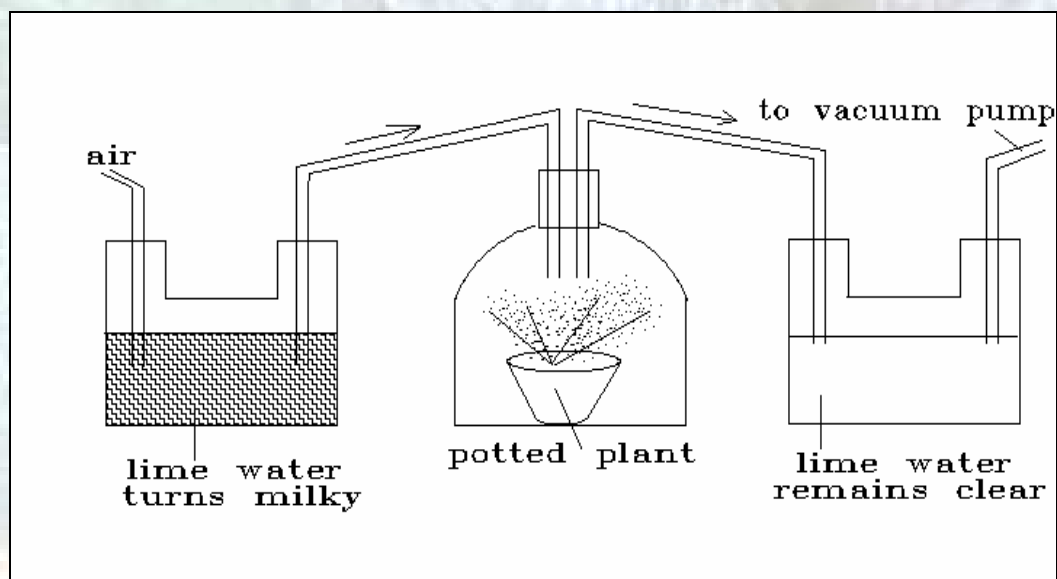

Fig. 4.17

Set up an experiment as shown. The limewater is used to show the presence of carbon-dioxide. It turns milky if CO_2 is present.

Observation: the limewater in B remains clear proving that the plant has used up all the CO_2 from the incoming air.

Created by Bernard Brochez

EXPERIMENT:

To show that O_2 is given off during photosynthesis.

Set up the experiment as shown. Gas will be collected in the inverted test-tube. To show that it's oxygen, you just introduce a glowing splint in the tube. The splint will re-light, since oxygen supports burning.

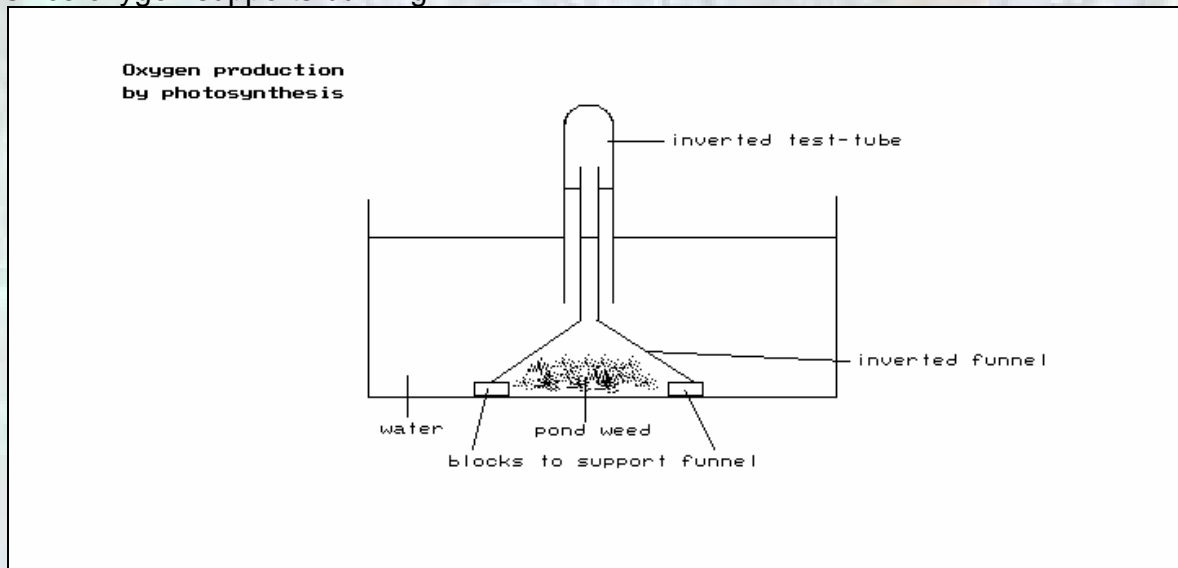

Fig

. 4.18

E. Compensation Point.

	<u>photosynthesis</u>	<u>respiration</u>
used	carbon-dioxide + water	carbohydrate + oxygen
produced	carbohydrate + oxygen	carbon-dioxide + water

The photosynthesis reaction is the reverse of the respiration reaction. In green plants as in all living organisms, respiration goes on all the time (day and night), while photosynthesis only takes place when there is light. In dim light (dawn or dusk), the rate of photosynthesis may become equal to the rate of respiration.

Result:

- All carbon-dioxide produced in respiration is used in photosynthesis.
- All oxygen produced in photosynthesis is used in respiration.
- The rate of carbohydrate breakdown in respiration is equaled by the rate of carbohydrate build up by photosynthesis.

In this state the plant is said to have reached its COMPENSATION POINT.

Created by Bernard Brochez

F. Removal of photosynthetic products.

If the manufactured sugars remained in the chloroplasts, their accumulation would SLOW DOWN the rate of photosynthesis and eventually the process would stop.

The starch-sugar compounds are easily reversible so that the stored starch is converted to sugar and removed by the phloem to storage areas (roots) or to places where they are needed for growth and repair.

There are 2 stages involved when photosynthesis takes place in the chloroplasts.

1. Light reaction

This first stage depends upon LIGHT. The chlorophyll converts LIGHT ENERGY into CHEMICAL POTENTIAL ENERGY which splits the water-molecules into hydrogen atoms and oxygen.

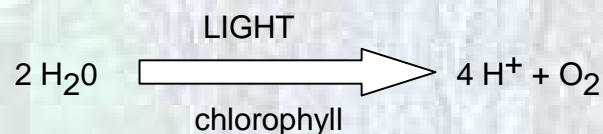

Some of this oxygen is used in respiration and the rest is given off to the atmosphere.

2. Dark reaction

This does not involve light. This reaction involves carbon-fixation. Carbon-dioxide is taken into the leaf and becomes incorporated into simple and unstable carbon compounds.

Energy is then transferred to these reactions by A.T.P.

The hydrogen atoms are also transferred to these reactions. The carbon compounds are changed into sugars (glucose) which is then changed into starch.

All these reactions are catalysed by enzymes.



SUMMARY:

Photosynthesis is the removal of hydrogen from water and its transfer to carbon-dioxide to form carbohydrates. This process requires Energy which the chlorophyll absorbs from light, and makes available.

Created by Bernard Brochez

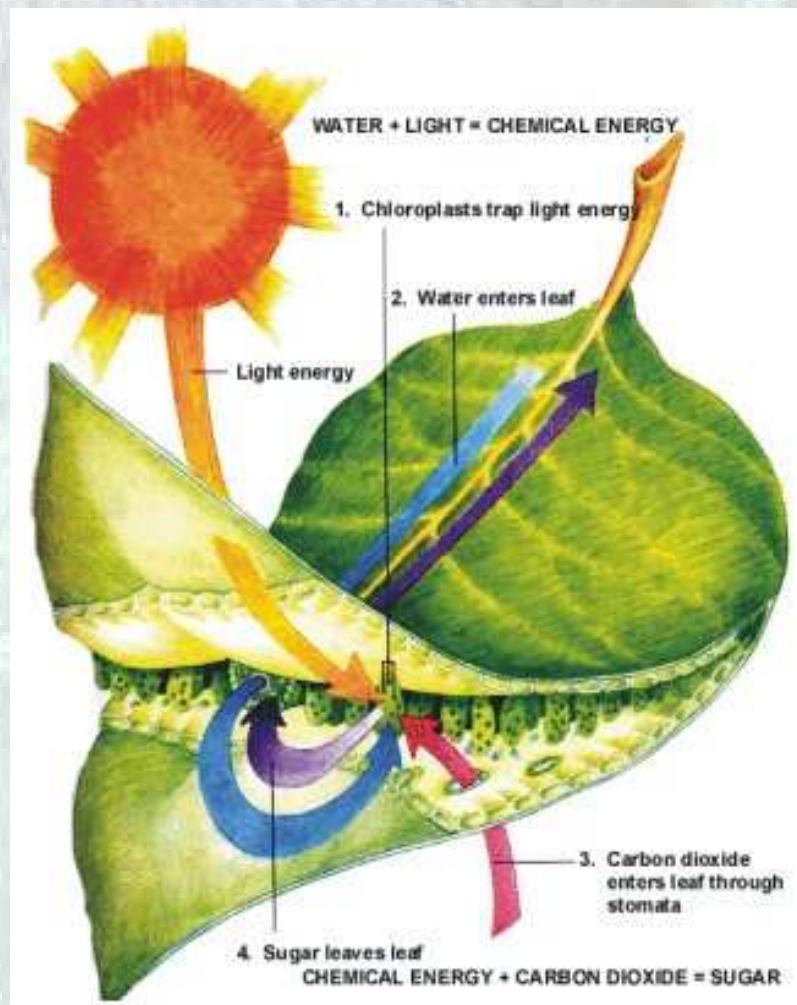

Fig 4. 19

5. MINERAL NUTRITION IN PLANTS.

The mineral elements needed by plants are absorbed from the soil in the form of salts. For example, a plant's needs for potassium (K) and nitrogen (N) might be met by absorbing the salt potassium nitrate (KNO_3). Salts like this come originally from rocks which have been broken down to form the soil (soil erosion). They are continually being taken up from the soil by plants or washed out of the soil by rain. They are replaced partly from the dead remains of plants and animals.

There are six Macro elements and seven Micro elements which a plant needs: (macro = large, micro = small).

This simply means that the macro-elements are needed in large amounts and the micro-elements in small amounts.

Macro-elements

Micro-elements

N,P,K,S,Ca,Mg,S

Fe,B,Zn,Mn,Cl,Mo,Cu

To demonstrate the importance of the various mineral elements, you grow the plants in water cultures.



Fig. 5.1

A full water culture is a solution containing the salts which provide all the necessary elements for healthy growth.

- Potassium nitrate for K and N
- Magnesium sulphate for Mg and S
- Potassium phosphate for K and P
- Calcium nitrate for Ca and N

Created by Bernard Brochez

From these elements together with carbon-dioxide, water and sunlight, a plant can make all its required substances.

Place wheat seedlings in test-tubes containing water cultures. Cover the tubes with Aluminium foil to keep sunlight out and to stop the growth of green algae.

Some of the tubes will lack one of the elements. For instance instead of Mg.sulphate you will use Mg.chloride to leave out Sulphur.

After some weeks you will see deficiency symptoms and from your observations you can deduce the function of the element in the plant.

Seedlings lacking Nitrogen will usually be stunted and have small pale leaves. This is because Nitrogen is a major constituent of amino acids and therefore proteins.

The lack of Magnesium will lead to small plants with yellow leaves. Since magnesium is needed for the production of chlorophyll, this light absorbing molecule is not made.

In arable farming, the ground is ploughed and whatever is grown is removed. There are no dead plants left to decay and replace the mineral salts. Farmers must replace them by spreading animal manure, sewage sludge or artificial fertilisers in measured quantities over the land.

Three manufactured fertilisers in common use are ammonium nitrate, superphosphate and compound NPK.

- Ammonium nitrate is rich in nitrogen but lacks all other nutrients. It is mixed with calcium carbonate to form a compound fertiliser such as Nitrochalk.

- Superphosphates are mixtures of minerals. They all contain Ca and phosphate and some have sulphate as well.

- Compound NPK: nitrogen-phosphorus-potassium. Are made by mixing ammonium sulphate, ammonium phosphate and potassium chloride in varying proportions.

If fertilisers are over-used they become a threat. Chemical fertilisers are easily abused. Improperly applied, they waste money, pollute water supplies and damage plants. If the soil solution becomes too concentrated, plants can no longer take up water from the soil, but instead may actually lose water by osmosis. Such "fertiliser burn " may dehydrate and kill the plants.

Any form of Nitrogen applied to the soil is also available to micro-organisms which may convert the nitrogen into forms that plants cannot use.

Fertilisers should be used correctly and in the right amounts.

Created by Bernard Brochez

Source:

- Complete proteins: meat (beef, pork, fish), eggs, milk, cheese, Soya-beans.
- Incomplete proteins: peas, beans, vegetables

A balanced diet should contain some of these protein sources.

Plants can build up all the A.A. they need from carbohydrates and nitrates but animals can't. They must therefore obtain their A.A. from proteins already made by plants or present in other animals. The diet must therefore include a minimum quantity of protein of one sort or another.

Functions: all the cells of the body contain a large amount of proteins:

Structural proteins: e.g. cell wall, cytoplasm-membrane

Functional proteins: e.g. enzymes...

Proteins are particularly important during periods of pregnancy and growth when new cytoplasm, cells and tissues are being made.

If proteins are eaten in excess, there will be more A.A. in the body than needed to produce or repair cells. Since A.A. can not be stored they are converted in the liver into carbohydrates which are oxidised into E. The waste material is lost as urine.

Test for presence of protein in Food.

1. Millons reagent test: Add a few drops of Millons reagent into a test tube containing protein (egg white, meat soup) and heat it.

=====> You will see colour changes into red or pink.

2. Add sodium hydroxide (NaOH) to any protein and add 2 drops of copper-sulphate sol'n and shake it well.

=====> The colour will change into purple or violet.

b) Fats and oils (lipids)

Structure: they contain only the elements carbon, hydrogen and oxygen.

- Source: animal fat, butter, oil of certain plants (coconuts, groundnuts) milk, cheese, egg-yolk...

Created by Bernard Brochez

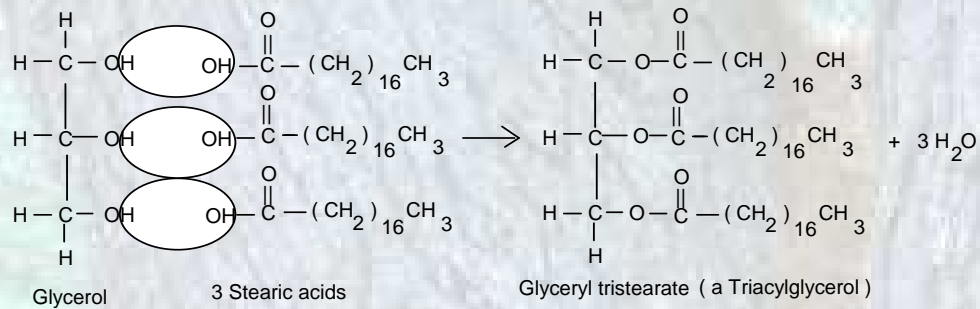

Function:

- 1) Protection for the body against high temp. differences.
- 2) With their high E value, they are useful storage substances.
- 3) Necessary because some vitamins are only soluble in fats.

Test:

- A lipid makes a paper translucent.
 - 2 drops of cooking oil are shaken with some ethanol until the fats dissolve. The alcoholic sol'n is poured into a test-tube containing some water.
- =====> A cloudy white emulsion is formed.

c) Vitamins

Structure: very complex chemical structure. Every vitamin has a different structure.

- source:

Vitamin C is found in oranges, lemons, tomatoes, fresh vegetables.

Vitamin D is found in cream, egg yolk.

If you don't eat enough of these vitamins you might get some of the following deficiency symptoms:

Vit C.: Weakness, haemorrhages of the skin (mouth and gums), anaemia, poor healing of wounds...all are symptoms of scurvy.

Vit D.: Abnormal bone formation, soft bones with swollen ends, all symptoms of rickets

d) Mineral salts

A wide variety of salts is essential for the chemical activities in the body.

Calcium
Magnesium
Phosphorus } Needed in bones and teeth

Iron } Necessary in the red pigment of blood (haemoglobin).

Created by Bernard Brochez

Sodium }
Potassium. } needed in nearly all the cells, nerves, body fluids

Iodine: } needed for the proper function of the thyroid gland.

Copper }
Cobalt } needed in very small amounts
Manganese. }
Sulphur }

A lack of calcium will lead to abnormal bone formation, and your teeth will get weaker.

A lack of iron will lead to **anaemia** (= you will have fewer red blood cells, which in turn leads to weakness).

e) Roughage.

- Fibres: consist largely of the cellulose in cell walls of plants. It can not be digested in man. It adds bulk to the food and enables the muscles of the A.C. to grip and to keep it moving by peristalsis.
Absence of roughage leads to constipation.

f) Carbohydrates

- Structure: They contain the elements C,H,O
General name: sugars.

a) simple sugars:

- Glucose: most important source of E
- Fructose: found in most fruits
- Galactose

b) Double sugars:

- Sucrose: 1 F + 1 G : in most plants
- Maltose: malt sugar
- Lactose: 1 Gal + 1 G: major sugar in milk

c) complex sugars:

- Starch: long chain of G. Found in rice, potatoes nshima.
- Glycogen: long chain of G. elements. Carbohydrates are stored as glycogen in the liver.
- Source: Milk, Fruits and green plants.

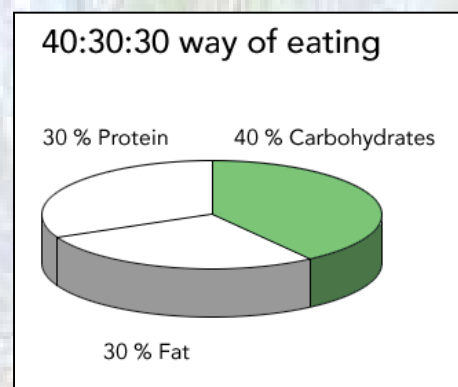

Fig. 6.2

Created by Bernard Brochez

- Functions: carbohydrates are oxidised in the body to provide E for muscular work.

- Test: starch: A little starch powder is shaken in a test-tube with some cold water. Add a little iodine sol'n. The sol'n will turn blue-black. So, any food sample containing starch will react the same. (E.g. a peeled potato).

- Test: Glucose:

A little glucose is heated to boiling point with some Benedict's sol'n. The colour changes from blue to green, yellow and finally a red precipitate is formed.

Daily dietary needs.

A balanced diet must contain enough carbohydrates and fats to meet our energy needs. It must also contain enough protein of the right kind to provide the essential amino acids to make new cells and tissues for growth and repair. The diet must also contain vitamins and mineral salts, plant fibre and water.

Energy can be obtained from carbohydrates, fats and proteins. The cheapest energy-giving food is usually carbohydrate; the greatest amount of energy is available in fats; proteins give as much energy as carbohydrates but are expensive.

Whatever mixture of carbohydrates, fats and proteins you eat; (Fig.6.1) the total energy must be enough to:

1. Keep our internal body processes working (heart beating, breathing action...)
2. Keep our body temperature at 37°C.
3. Meet the needs of work and other activities.

It is obvious that someone doing hard labour will need more energy than someone who sits in an office all day. See Fig.6.4

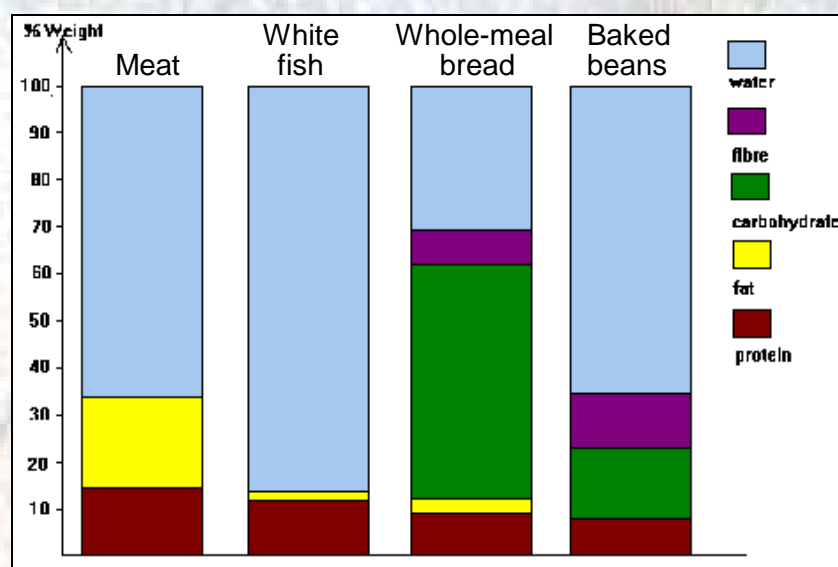

Fig.6.3

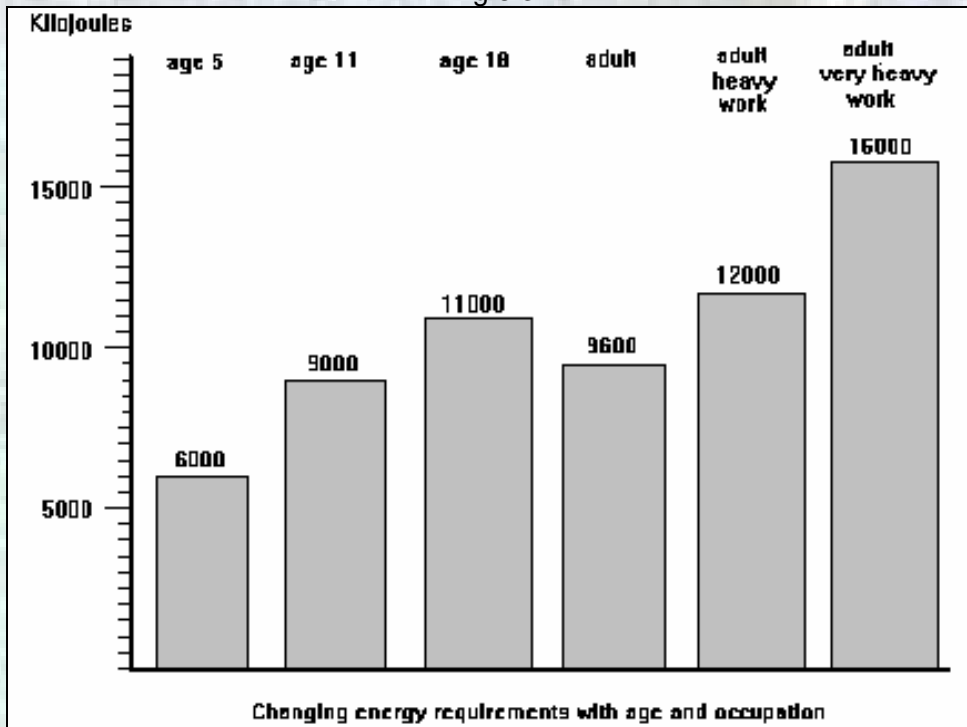

Fig.6.4

Table: Energy requirements in kJ.

8 hours asleep	2400
8 hours awake; relatively inactive physically	3000
8 hours physically active	6600

	Total 12 000

Malnutrition

In developing countries it means starvation, since there is a shortage of food or rather of money to buy it.

Malnutrition in the western world means the eating of improper balanced meals. A lot of people do not eat properly. A lot of them eat fast foods (hamburgers, chips, coke); the businessmen eat business-lunches or dinners which include too much fats, and alcohol.

This can lead to heart attacks, obesity, constipation.

THE DIGESTIVE SYSTEM

The purpose of digestion: food taken into the mouth must enter the blood stream and be distributed to all living regions.

Definition: Digestion is the process by which insoluble compounds, consisting of large molecules are broken down into soluble compounds having smaller molecules. These smaller molecules, in solution, pass through the intestine wall and enter the blood stream. Digestion and absorption take place in the A.C.

The A.C. is a muscular tube , running from mouth to anus. Some regions have particular functions. As the food is passing through the A.C., it is broken down in stages until the digestible material is dissolved and absorbed. The indigestible residue is expelled through the anus.

For digestion, we need chemical compounds called ENZYMES. There are 2 main groups.

1. Intracellular enzymes: Carry out functions in the cytoplasm of the cell in which they are made.
2. Extracellular enzymes: Are secreted out of the cells in which they are made to be used elsewhere (e.g. in A.C.)

A. Movement of food through the A.C.

Ingestion: The act of taking in food into the A.C. through the mouth.

Swallowing: The act of bringing the food from mouth to gullet.

Peristalsis: The walls of the A.C. contain muscles. These muscles by contracting and relaxing alternately urge the food in a wave-like motion through the various regions of the A.C.

Egestion: The expulsion from the A.C. of the undigested remains of food.

B. Digestion in the mouth.

In the mouth the food is chewed and mixed with saliva.

Chewing: reduces the food to suitable sizes for swallowing and increases the available surface for enzymes to act on. Saliva is secreted by 3 pairs of glands (1 to 1, 5 l./day). It contains an enzyme: salivary amylase which acts on cooked starch. It breaks the starch down into maltose (a soluble sugar).

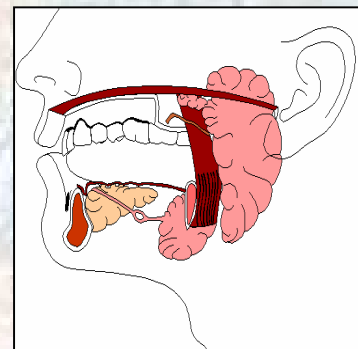

Fig.6.5

C. Digestion in the stomach.

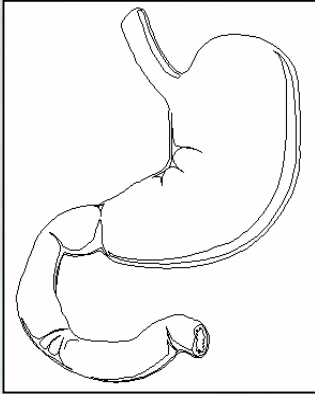

Fig.6.6

The food enters the stomach through the cardiac sphincter. The stomach has flexible walls and it can be extended by the accumulation of food. The food is retained in the stomach by the closure of the pyloric sphincter at the end of the stomach. The food is released in small parts by the opening of that sphincter. The stomach produces gastric juice. The gastric juice contains the enzyme PEPSIN. The enzyme changes proteins into peptides (smaller chains of A.A.)

In young children, the enzyme RENNIN is present. It clots the proteins in milk which makes that the milk stays longer in the stomach.

Stomach also secretes Hydrochloric acid (HCl). Its function is to make an acid medium. Pepsin can only work in acid conditions. It also kills many bacteria taken in with the food. Gastric juice + food is mixed by contractions of the stomach. The result is a creamy fluid called CHYME.

From time to time, small quantities of chyme leave the stomach going into the duodenum.

D. Digestion in the duodenum.

The duodenum is the first part of the small intestine.

An alkaline juice from the pancreas and bile from the liver are poured in it.

1. Pancreas: cream coloured gland below the stomach. The pancreas makes enzymes.

Trypsin: acts on proteins & peptides.

Proteins }
Peptides } A.A.

Amylase: acts on starch

Starch -----> maltose

Lipase: acts on fats.

Fats -----> glycerol + fatty acids.

Created by Bernard Brochez

2. Bile: green fluid made in the liver, stored in the gall bladder and conducted to the duodenum by the bile duct. It contains the breakdown products of the red pigment from decomposing red blood cells, salts, cholesterol and fatty acids.

Function: Dilutes contents of the intestine

Bile salts reduce the surface tension of fats so emulsifying them =====> tiny droplets are formed =====> more rapid digestion.

E. Digestion in the ileum.

Five enzymes are secreted by glands lying in between the villi.

Peptidase: peptides-----> A.A.
Lipase: fats-----> glycerol + fatty acids.
Maltase: maltose-----> glucose.
Sucrase: sucrose----->glucose + fructose.
Lactase: lactose-----> glucose + Galactose.

All the digestible material is now reduced to soluble compounds which can pass through the intestinal lining and into the blood stream.

The glandular lining of the A.C. is continually secreting mucus which helps to lubricate the passage of food, but which also prevents the digestive juices from reaching and digesting the A.C. itself. The cells which make the protein digesting enzymes make them in an inactive form. The enzymes can't work until they reach the cavity of the A.C., where they are activated by the chemicals present.

F. Absorption in the ileum.

Nearly all the absorption of digested food takes place in the ileum.

Adaptations to its absorbing properties.

It is long. Its initial surface is greatly increased by thousands of finger-like projections called VILLI.

The lining epithelium is thin and fluids pass rapidly through it.

There is a dense network of blood capillaries in each villus, so digested food substances can be transported to the liver, from where it is distributed all over the body.

The small molecules of digested food (A.A. + glucose) pass through the epithelium and the capillary walls and enter the blood plasma. The capillaries unite to form veins, and those join to form the Hepatic Portal Vein.

This vein carries all the blood from the intestines to the liver. From here, the digested food reaches the general circulation. Some of the fatty acids and glycerol (from the digestion of fats), enter the blood capillaries of the villi, but a large proportion may be

Created by Bernard Brochez

recombined into fats and these go into the lacteals. Lacteals are part of the lymphatic system. (Lacteal = lymphatic vessel)

So the most of the fats absorbed in the intestine reach the circulation by this route. The fluid in the lymphatic vessels is called lymph and it is similar in composition to tissue fluid.

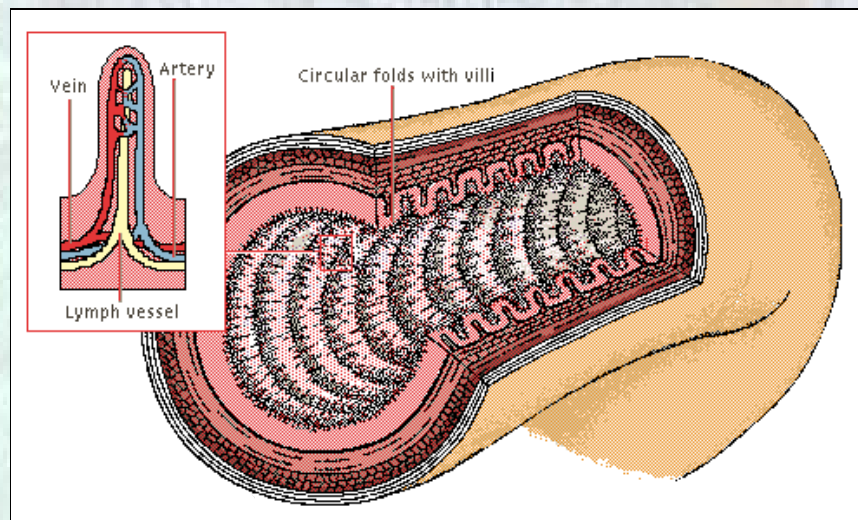

Fig.6.7

G. The appendix.

This is a small, vestigial structure in man. In herbivores (e.g. rabbit) it is much larger. It is here that most of the cellulose digestion takes place, largely as a result of bacterial activity.

H. The large intestine (colon + rectum).

Material passing into the large intestine: water, undigested matter, roughage, bacteria, mucus, dead cells of the lining of the A.C.

The large intestines absorb much of the water from the undigested residues.

The semi-solid waste, the faeces, is passed into the rectum by peristalsis and is expelled at intervals through the anus.

Utilisation of digested food.

The products of digestion are carried round the body, in solution, by the blood. From the blood, most living cells are able to absorb and metabolise glucose, fats and A.A.

a) Glucose: during respiration in the cells, glucose is oxidised to $\text{CO}_2 + \text{H}_2\text{O}$. This reaction releases energy to drive the many chemical processes in the cell. (e.g. contraction of muscle cells, electrical changes in nerve cells.)

Created by Bernard Brochez

b) Fats: are incorporated into cell membranes and other structures in cells. They are also oxidised to CO₂ and H₂O releasing energy (twice as much as from glucose).

c) A.A.: are absorbed by cells and reassembled to make new proteins.

THE LIVER.

Large, reddish-brown organ.

It receives all the blood which leaves the A.C.

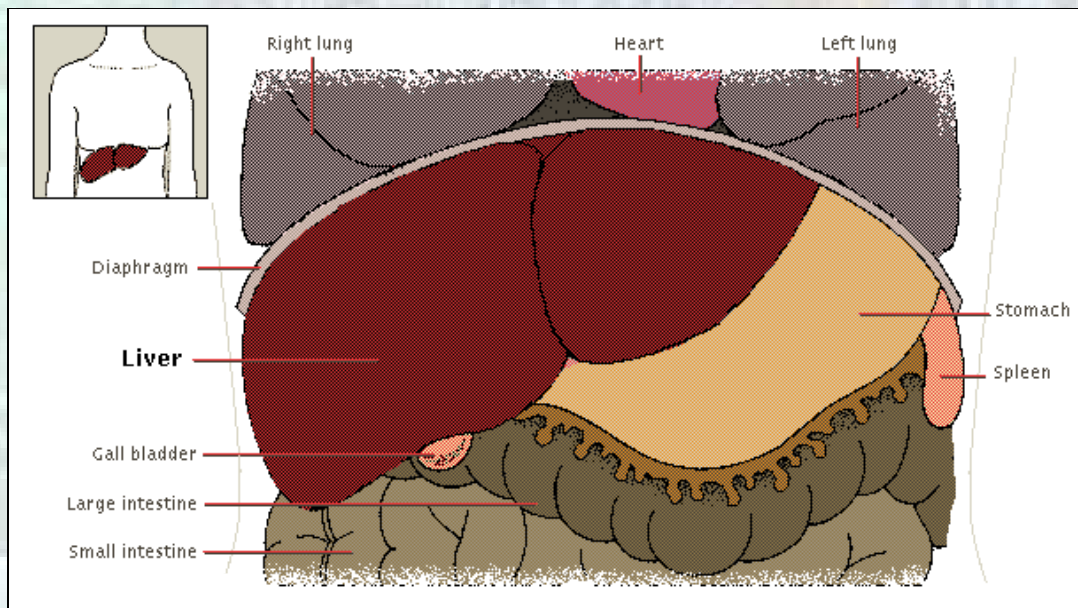

Fig.6.8

FUNCTION.

1) Regulation of blood sugar.

The liver is able to convert glucose, A.A. and other substances to an insoluble carbohydrate: Glycogen and store it.

If the conc. of glucose in the blood falls below 0.1 % some of the stored glycogen will be converted into glucose and released in the blood circulation. If the level is too high, the liver will convert glucose into glycogen.

2) Formation of bile.

Bile is partly an excretory product. It's alkalinity and salt content helps to provide favourable conditions for digestion in the duodenum and ileum. Bile is formed in the liver and stored in the gall bladder.

3) Storage of iron.

R.B.C. are decomposed in the liver and the iron (Fe), present in the haemoglobin, is stored.

Created by Bernard Brochez

4) Deamination of A.A.

Excess A.A. can not be stored in the body. So, A.A. which are not used to make proteins are converted to carbohydrates by removing the amino-group (NH_2). The amino-group is converted to urea, which in turn is eliminated by the kidneys.

5) Formation of fibrinogen.

Fibrinogen is a protein in blood plasma. It plays an important role in the clotting process of blood.

6) Detoxication.

Poisonous compounds from metabolism or taken in with the food are converted to harmless substances (e.g. alcohol)

7) Storage of vitamins.

The fat soluble vitamins A and D are stored in the liver. That's why animal liver is a valuable source of these vitamins in the diet.

CONCLUSION

The liver has many functions, but the result of its work is that the internal environment is controlled and kept constant, whatever your diet may be!!

Exercise: Fill in the labels.

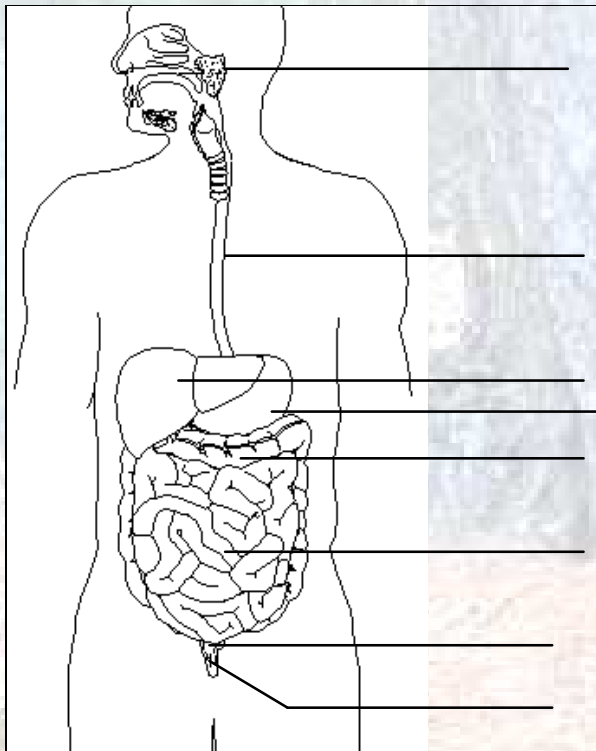

Fig.6.9

Created by Bernard Brochez

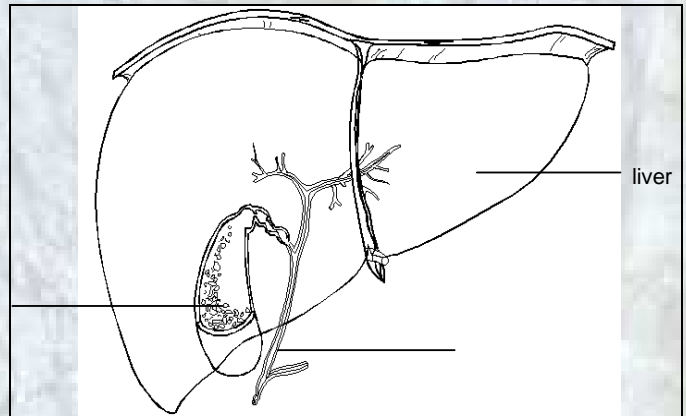

Fig.6.10

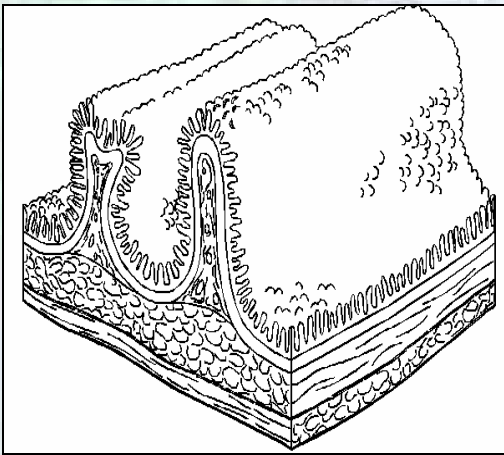

Fig.6.11

From which region of the digestive system could this cross-section have been made?

7. TEETH

A. Introduction

Teeth are bone-like structures found in the mouth. They are mainly made up of calcium, sulphates and phosphates. There are four types of teeth:

1. **Incisors:** flat, but sharp; used for cutting and tearing.
2. **Canines:** pointed and sharp; used for pricking, cutting and tearing food.
3. **Premolars:** big, broad and have cusps for grinding.
4. **Molars:** like premolars, but bigger, also for grinding.

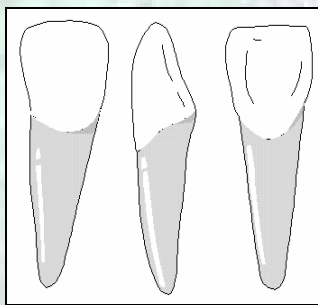

incisors

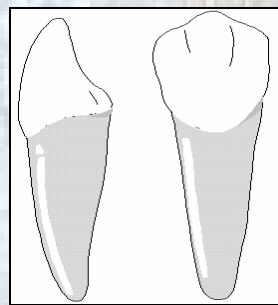

canines

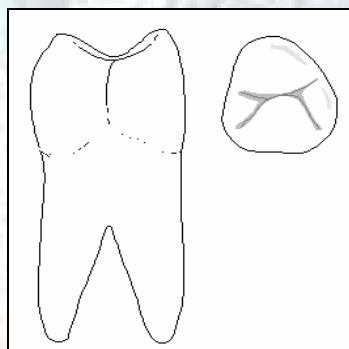

premolar

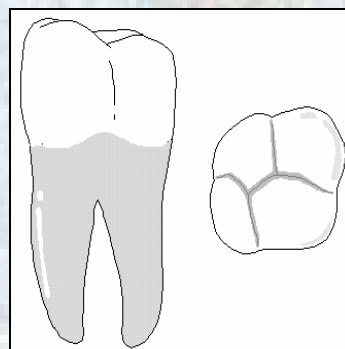

molar

Fig 7.1

Teeth have 3 parts: neck, crown and root. Mammals (especially man) have two sets of teeth:

Created by Bernard Brochez

a) **Milk dentition:** Milk teeth come out at the age of 5 months and above. (Incisors, canines and premolars only = 20 altogether). They are removed between the age of 5 and 13 to allow a permanent dentition which includes molars (32 teeth).

b) **Permanent dentition:**

ENAMEL: a hard coating over the dentine for protection against wear and tear. Enamel is the hardest substance in the body.

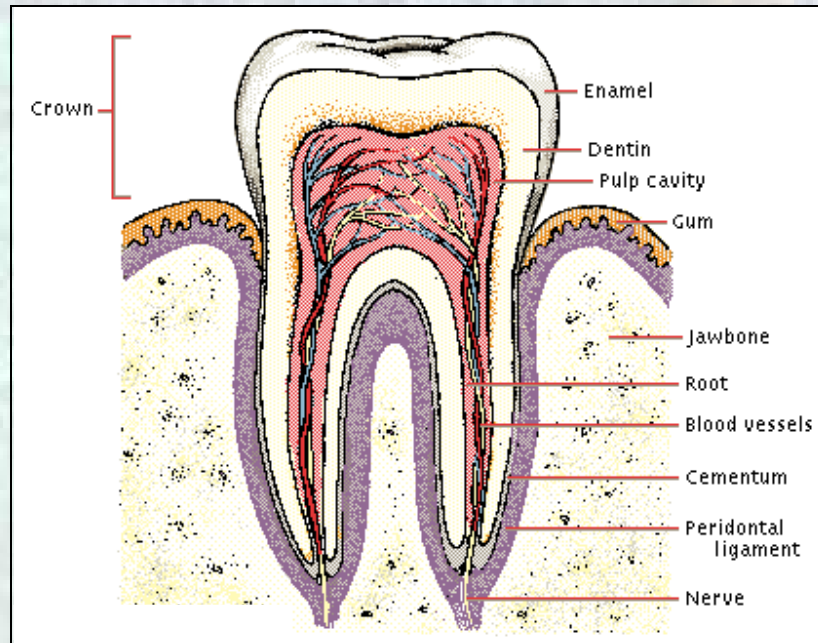

Fig 7.2

DENTINE: it forms the structure of the tooth and is made up of sulphate and phosphate salts of Calcium.

PULP CAVITY: A cavity in the tooth that contains blood vessels and nerve cells.

BLOOD VESSELS: They supply nutrients and oxygen to the tooth for its growth and maintenance.

NERVE CELLS: Allow sensitivity of the tooth.

GUMS: Flesh which holds the teeth firmly together.

JAW BONE: It is the bone which has the sockets for the roots of the teeth.

CEMENT: It glues the roots of teeth to the jawbone.

DENTAL FORMULA: It reveals the number and type of teeth present on half of the upper and lower jaw of a mammal.

Created by Bernard Brochez

MAN : 2 incisors 1 canine 2 premolars 3 molars (upper jaw)

 2 1 2 3 (lower jaw)
 2 I 1 C 2 PM 3 M 2123
or
 2 I 1 C 2 PM 3 M 2123

DOG: 3142 COW: 0033
 3143 1133

PIG: 3143 RAT: 1033
 3143 1023

A herbivorous animal has no incisors and canines on the upper jaw, since they don't have to cut and tear their food. The teeth continue to grow throughout the animal's life, since they wear down. In the back of the mouth, molars and premolars on both jaws fit exactly in one another. The teeth get sharp ridges of enamel, ideal for grinding and crushing.

Digestion of cellulose is the work of bacteria (no enzymes from the animal itself). So it is important for herbivores to grind properly, since it increases the surface area for bacteria to work on.

B. The health of your teeth.

Dental Caries

Tooth decay is a disease which destroys the tooth structure.
4 elements are necessary to cause it:

1. mouth bacteria
2. sweetened foods and liquids
3. dental plaque
4. susceptible tooth surface.

- The bacteria that thrive on sweetened foods break down the sugar in these foods producing acids.
- Dental plaque sticks to the teeth, harbours bacteria and holds the acid against the tooth surface.
- The acid attacks the surfaces of the teeth and begins to dissolve the tooth enamel. Between the teeth there are many pits and fissures. It's here where decay usually starts. The gaps are difficult to reach with a brush. The decay penetrates the enamel and reaches the dentine. Once here, the decay

Created by Bernard Brochez

progresses rapidly and reaches the pulp cavity. Often the adjoining teeth are affected with caries if the original decay is not detected and treated.

C. The care for your teeth.

1. TOOTH-BRUSHING: if possible, immediately after a meal.



Fig 7.3

2. FLOSSING: With a thin ribbon made of strong nylon you remove food debris.



Fig. 7.4

3. Visit the dentist every six months, or follow his/her instructions.

4. Dental disclosing material = a harmless food dye to make plaque visible. You will see if your brushing is effective.



Fig. 7.5

Teeth are coloured after chewing a Disclosing chewing gum

8. TRANSPORT IN FLOWERING PLANTS.

The root endings of an oak tree may be hundreds of feet away from its leaves. Roots and leaves are connected by the vascular tissues, which transport water and mineral salts from the roots to the leaves, and conduct food from the leaves to the roots, as well as to growing buds, flowers and fruits.

The vascular tissue (the wood in roots and stems, and the veins in leaves) also provides strength and support to the plant.

A. Development of Vascular Tissue.

Xylem and Phloem tissues are built up from newly formed cells, which elongate behind meristems (= Regions of dividing cells in growing areas of the plant, e.g. root and shoot tips).

After elongation has taken place, other changes may occur in the cell wall and cell contents.

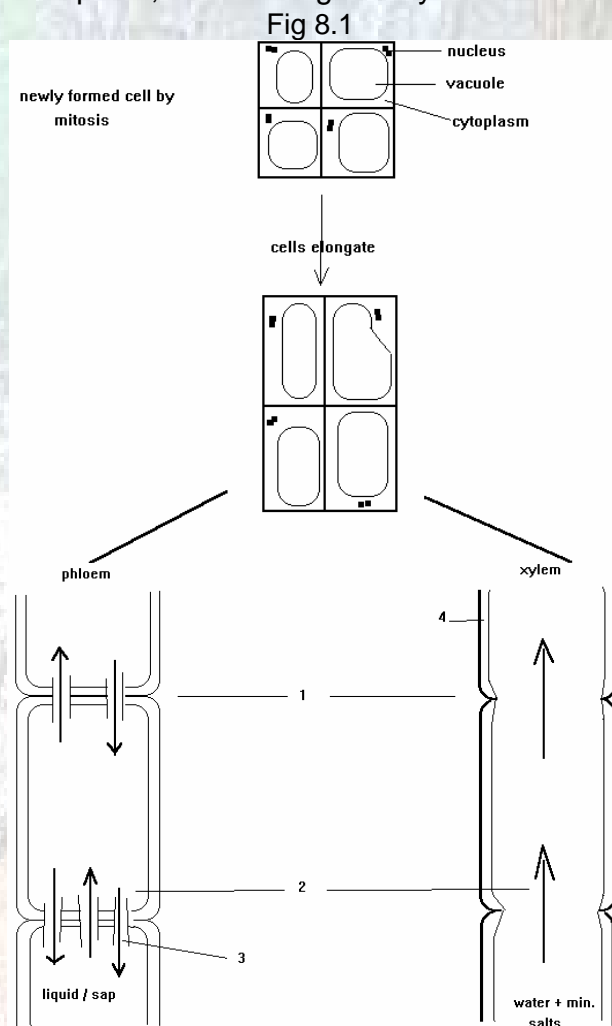

Created by Bernard Brochez

1. cross walls break down partially
2. living contents pushed to the edge
3. strands of cytoplasm go through pores

1. crosswalls break down completely to form sieve plates
2. Living contents die

4. Extra wall of lignin is made for strength

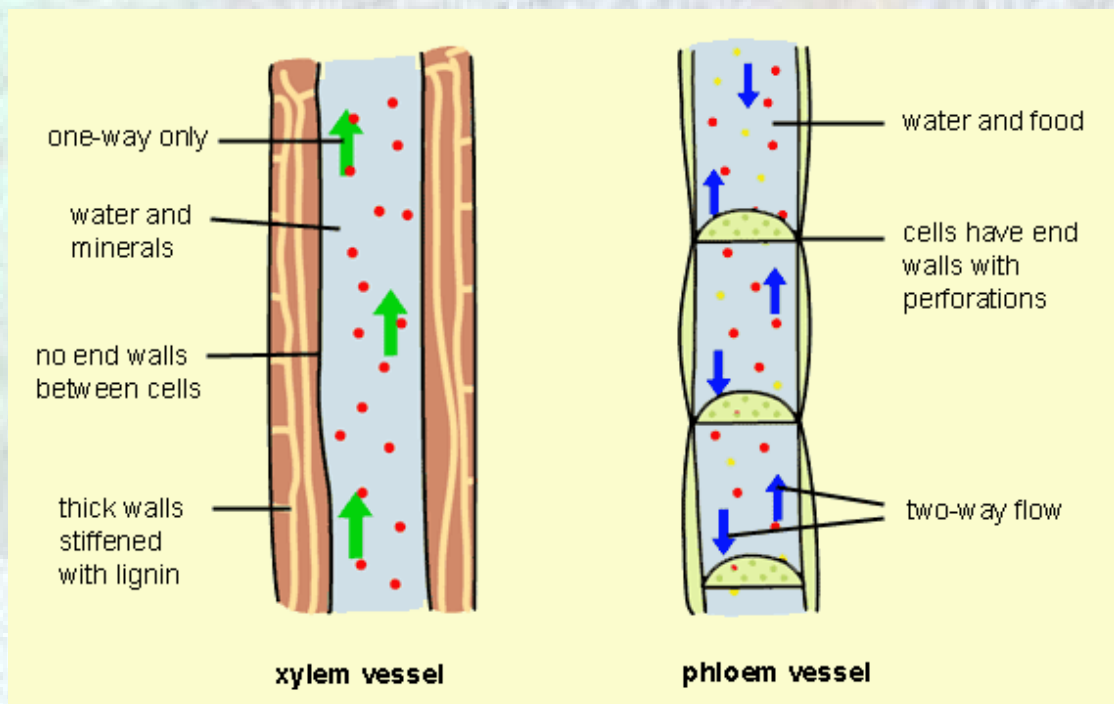

Fig. 8.2

B. Translocation in Vascular tissue.

1. Phloem.

Sap moves in either direction within the phloem sieve tubes. Phloem cells must be alive for translocation to occur.

Translocation may be due to:

- a) High turgor pressure in leaves forcing sap through the phloem elements towards the roots where the turgor pressure is lower.

Created by Bernard Brochez

Munch's model of mass flow in the phloem.

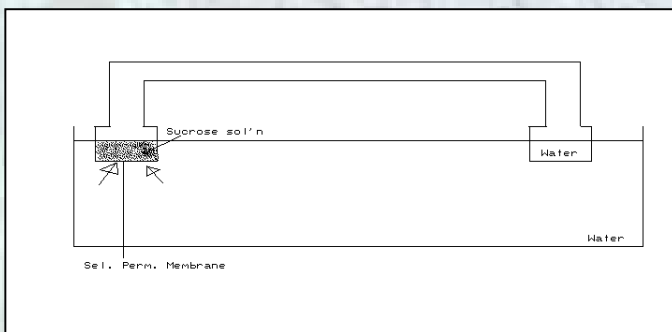

The selective permeable membrane is permeable to water but not to sucrose. A sucrose sol'n is placed in the left-hand container, plain water in the right. The tube is then immersed with its ends in a water bath. Water enters the sucrose sol'n by OSMOSIS,



The sol'n rises into the neck of the tube and flows across to the right hand chamber, where water is eventually forced out through the membrane.

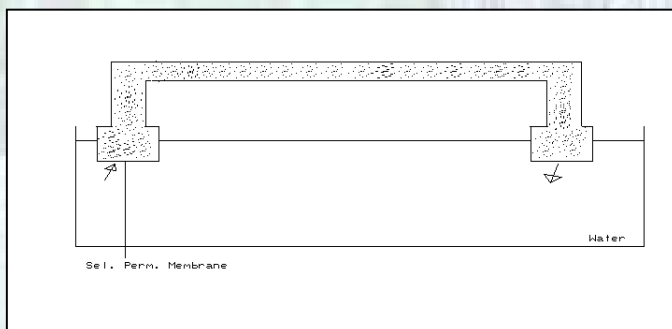

This system stops when the sucrose conc. becomes equal in the 2 chambers, but in a living plant, some areas constantly produce sucrose as others remove it, and movement would continue.

Fig. 8.3

b) The sucrose enters the phloem by **ACTIVE TRANSPORT**. (= the process in which energy is expended in moving a substance against its conc. gradient. e.g. Na/K pump)

c) Sap flows along the strands of cytoplasm from one element to the next.
Fig 8.2

ACTIVE TRANSPORT - MECHANISM.

E.g. Sodium Potassium pump.

Created by Bernard Brochez

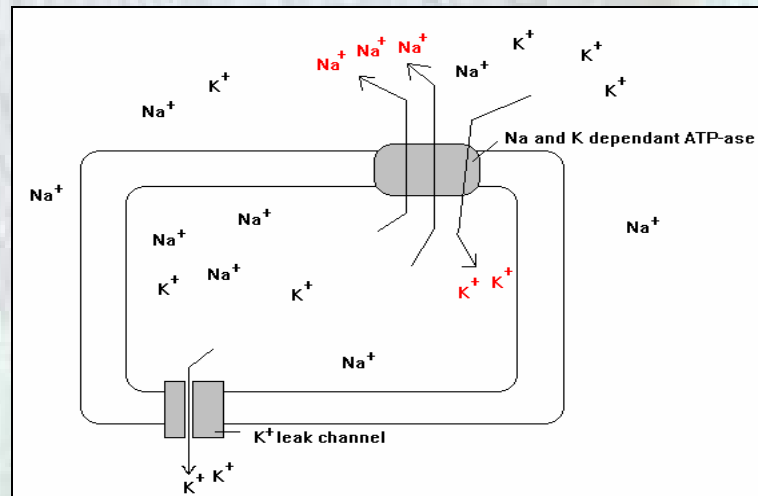

Fig 8.4

In the cell membrane, there is an enzyme: the **Na and K - dependant ATP-ase**. This enzyme pumps out 3 Na⁺ for each 2 K⁺ it pumps into the cell.

As a result, the interior of the cell becomes more negative compared with the outside of the cell.

Additionally, in the cell membrane there is also a K⁺-leak channel (a protein), which lets Potassium leak out of the cell.

As a result, the inside of the cell becomes even more negative than the outside.

How does this system actually work?

Both Glucose and Na⁺ have to bind to different sites of the carrier protein. Both can now move in, because of the electrochemical gradient of Na⁺. The greater the electrochemical potential of Na⁺, the faster Glucose is transported. The Sodium that came in with the Glucose, will later be pumped out again by the above-mentioned enzyme.

2. Xylem.

Movement of water and mineral salts within the xylem is due to evaporation of water from the leaves (transpiration)

Transpiration pulls up water to the shoot or stem from the roots. This suction of water would not work beyond a certain height without:

The existence of very long narrow xylem vessels carrying thin columns of water upwards. The walls of the vessels are strengthened with LIGNIN so that they are resistant to pressure changes and do not collapse.

The strong forces of attraction between water molecules (Van der Waals) and between water molecules and the vessel walls that enable the water column to be pulled or stretched without breaking.

Created by Bernard Brochez

C. The transport system in a stem.

In the stem the vascular tissue is organised in bundles, the vascular bundles. The phloem lies on the outside while the xylem lies on the inside. The two tissues are separated by cambium-cells which make new xylem-cells and new phloem-cells.

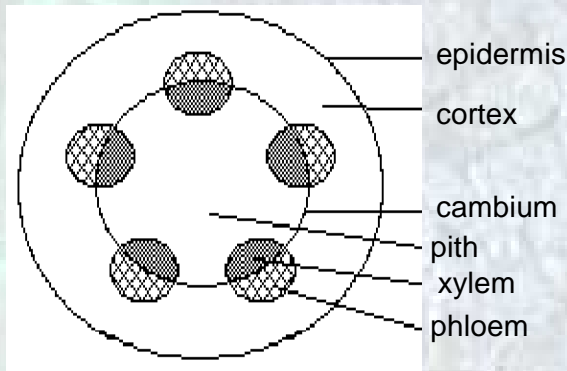

Fig 8.5 Cross section

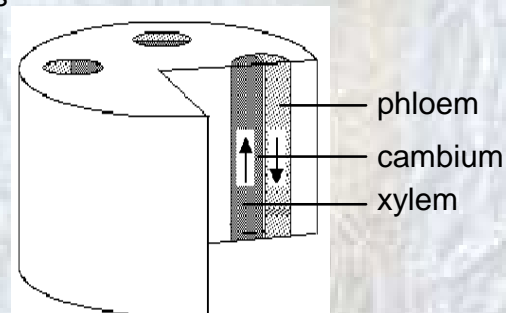

Fig 8.6 Radial section

D. Transport system in a root.

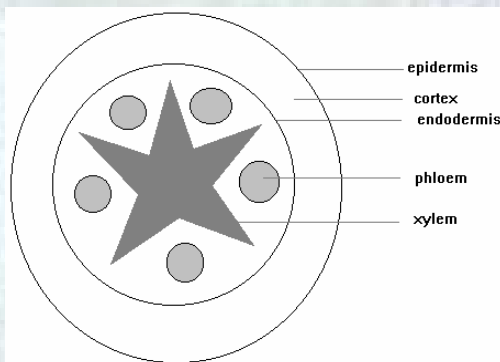

Fig 8.7 Cross section

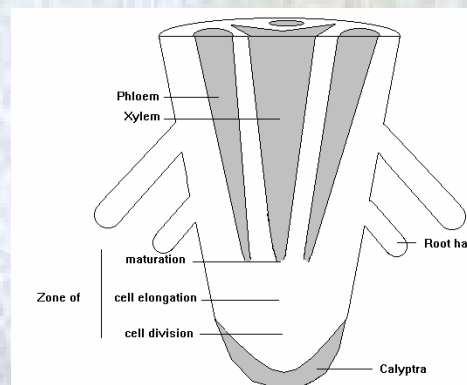

Fig 8.8 Longitudinal section

Root Hairs

Water from the soil may pass across via the following pathways (See fig 8.9):

- via the intercellular space between cells (not shown)
- via the cell walls of adjacent cells
- via the vacuoles, cytoplasm and walls of adjacent cells.

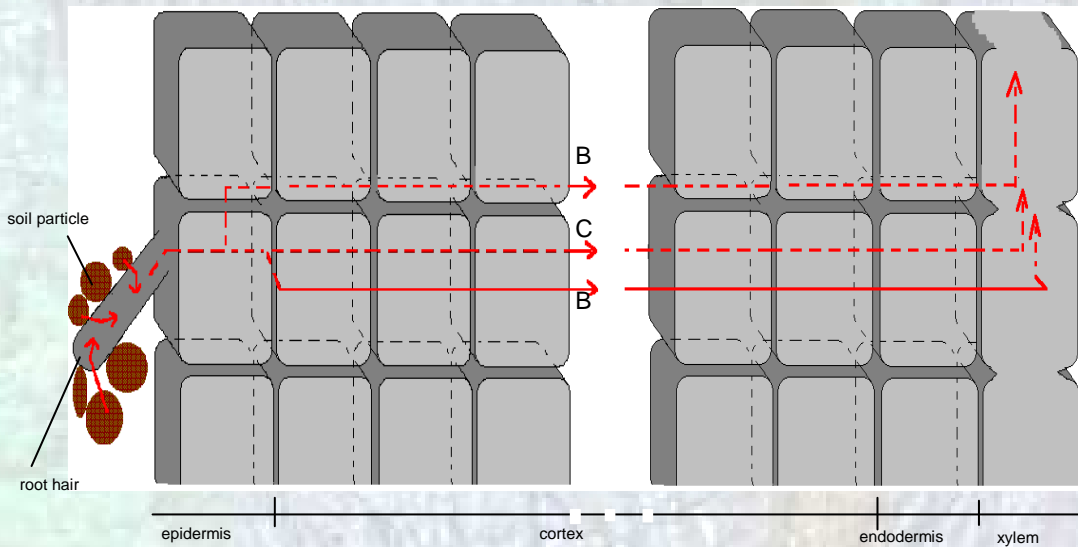

Fig 8.9

A and B are the main pathways by which water passes across the cortex. The water is taken from the soil by the root hairs as a result of osmosis.

The soil water passes from the region of high osmotic potential to the region of low osmotic potential. Although soil water has mineral salts dissolved in it, they only make a very weak solution, and the cell sap of the root hair is more concentrated than this. The water which comes in, dilutes the cell sap, making it weaker than its neighbouring cell's content. The water moves to the next cell by osmosis.

The water enters the vacuoles of the root hair cells and passes across the cortex by the processes A and B described above.

If transpiration is reduced, this osmotic intake produces a push or positive pressure, forcing the water into the xylem and up the stem (= root pressure)

Exp. Cut off a plant near the ground and seal the remaining part of the stem with a glass tube and some Vaseline. After some time you will see the action of the root pressure.

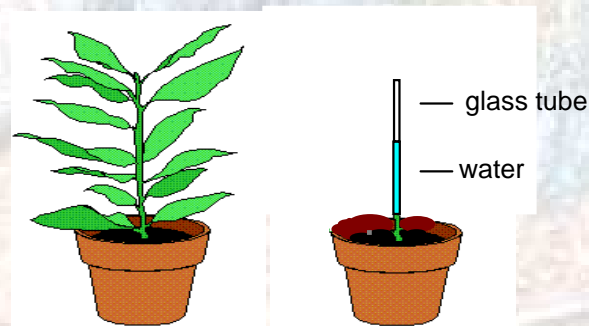

Fig 8.10

Created by Bernard Brochez

Active transport for ion uptake in roots.

The process in which energy is expended in moving a substance through a membrane against its concentration gradient.

The source of Energy may be the high-energy molecule ATP

The Xylem and phloem is continuous from roots up to the stem and leaves.

Some of the epidermal cells of the root become hairs by forming extensions that grow among the soil particles. Root hairs anchor the plant in the soil and increase the surface for absorption of water and minerals. It's important that root hairs form in the zone of maturation rather than in the zone of elongation. If root hairs would be made in the elongation zone, where the cells are pushing through the soil, the delicate extensions growing out sideways between soil particles would be pulled off.

The root cap (calyptra) protects the growing root. It wears off at the outside but is constantly repaired from the inside. The outer cells let go and serve as a gliding powder for the penetrating root.

E. TRANSPIRATION.

It is the loss of water by evaporation through stomata in the shoot system of a plant. Photosynthesis is using about 1% of the energy. The main part of the solar Energy is evaporating water.

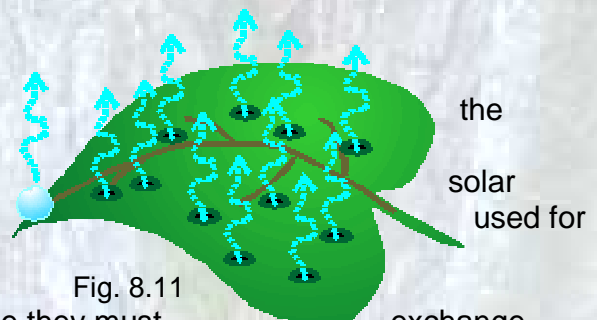

Fig. 8.11

Leaves inevitably lose water (vapour), because they must exchange gasses with the atmosphere. Evaporation increases with the amount of surface area exposed to the air and mainly leaves make up most of the exposed area.

The leaf's waterproof cuticle helps to reduce evaporation but since it is relatively impermeable to gases, it prevents Carbon-dioxide from getting in.

Stomata are pores that allow leaves to reduce water loss and still exchange CO₂ and O₂ (and water) with the atmosphere.

The turgor pressure in the mesophyll-cells forces water outwards through the cell-walls. From the outer surface of the cell walls, the water evaporates into the intercellular spaces and diffuses out of the stomata.

The bigger the leaves, the more rapid transpiration takes place. (That's why a cactus has thorns instead of leaves).

Transpiration is inevitably linked with photosynthesis. If CO₂ has to come in, water-vapour is bound to go out.

The bigger the leaves, the faster photosynthesis can take place, but the faster transpiration will be.

Created by Bernard Brochez

Transpiration is also beneficial for a plant. It can pull sap up through the xylem of a plant.

Since water gets out of the leaves, the concentration of the cell sap increases. So these cells will absorb water from their neighbouring cells and consequently from the xylem which brings water from the roots.

Hales took three identical twigs and removed some of the leaves (see Fig. 8.12). The three beakers were then left in the sunlight for some hours.

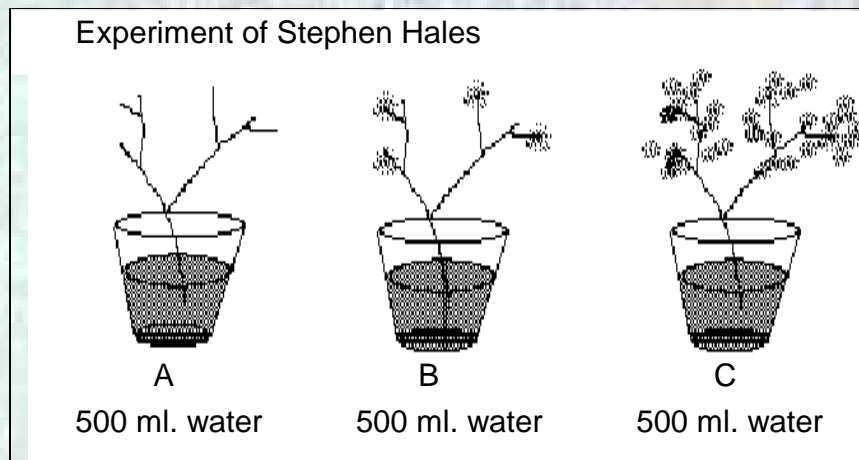

Fig 8.12

After the experiment: A: 450 ml. water
B: 300 ml. water
C: 150 ml. water

The leaves are responsible for the loss of water!!!!!!

The pull of water from above is now known as transpiration pull. The movement of water depends on the leaves being dry and exposed to the air. Water is pulled up more strongly on bright, sunny, dry days than on cloudy, damp days.

The pull slackens at night.

⇒ Evaporation of the leaves is responsible for the pulling up of water.

F. ENVIRONMENTAL EFFECTS ON TRANSPIRATION.

a) Temperature.

- an increase in temp. increases the capacity of the air for water vapour. Transpiration will therefore increase.

Created by Bernard Brochez

- if the leaf becomes warm, evaporation from it occurs more rapidly.

b) Humidity.

- Since in humid conditions, the atmospheric air is saturated with water vapour, little more can be absorbed from the plants: transpiration will be reduced.
- In a dry atmosphere, transpiration will be fast.

c) Light intensity.

Direct sunlight without a warm atmosphere will increase transpiration since the leaves absorb solar energy and their temp. rises. This causes problems in winter on a sunny cold day: the soil is frozen so no water can be absorbed.

d) Wind.

- No wind: around the leaf, the air will be saturated with water vapour ---> transpiration is reduced.
- Wind: the water vapour will be taken away from the leaf and transpiration increases.

Practical exercise

Learning Goals

1. Students will be able to recognize transpiration and explain its value to the plant.
2. Students will be able to explain how transpiration affects climate

Time:

- Teacher introduction: 20 minutes
- Activity set-up: 15 minutes
- Student observation: 30 minutes
- Discussion/assessment: 15 minutes

Materials for Each Team of Students

- Transparent plastic cup to be used as the top of the terrarium
- container or additional plastic cup for the bottom of the terrarium
- Square piece of cardboard between the two cups
- Small cutting of a house plant
- Petroleum jelly
- Lamp or source of sunlight
- Water
- Scissors

Procedure

1. Using the scissors, make a small hole (just big enough for the plant stem) in the center of the piece of cardboard.
2. Pull the plant stem through the hole and seal around the hole with petroleum jelly.
3. Fill the bottom cup with water and place the stem with the cardboard collar into the cup. Cover with the clear plastic cup as shown.

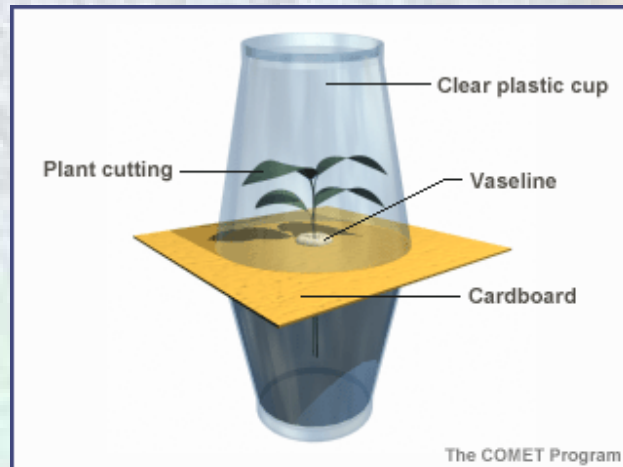

Fig. 8.13

4. Put the small terrarium in the sun or under a lamp.
5. In fifteen minutes, you should begin to see droplets of water on the sides of the clear inverted cup. More moisture will accumulate with time.
6. If possible, leave the terrarium cups set up in the classroom for several days and measure the amount of water transpired.
7. Ask students to calculate the water loss per square centimeter of leaf area.

Observations and Questions

1. Where does the moisture come from that accumulates along the sides of the top cup?
2. How do you know the water is coming from the plant and not just evaporating from the water in the cup?

Assessment Ideas

- Challenge students to imagine that their small plant was a large tree with a thousand times as many leaves. Ask them to assume that this tree transpires just like their plant and calculate how much water it would transpire.
- Now ask them to imagine a small forest with 1000 such trees. How much water would transpire?
- Ask if they think this much water going into the air in that area might affect the climate at all. Why or why not?

G. ADAPTATIONS OF PLANTS TO CONTROL TRANSPIRATION.

a) Leaf fall.

Deciduous trees shed their leaves in autumn. Otherwise, transpiration would still take place, and little or no water can be taken up from the cold or frozen soil.

b) Leaf shape.

- Pine needles will transpire less than the broad, flat deciduous leaves.
- Waxy cuticles and the stomata sunk below the epidermis level reduce transpiration (found on plants which grow in cold or dry conditions).

Evergreen plants will have one or more of these leaf characteristics.

c) Stomata.

Can close to prevent further transpiration. However, it is not proven yet that a high rate of evaporation results in the closing of the stomata. This only happens in extreme conditions.

If the loss of water exceeds the uptake of water, the plants wilt, the cells of the leaves become flaccid (flabby) and the stomata close to prevent further evaporation. Sometimes water is lost by transpiration faster than the xylem can replace it.

When the water-potential in the leaves becomes too low, the hormone **ABSCISIC ACID** is quickly synthesised. This hormone causes the guard cells to lose their turgor and the stomata close until the delivery of water through the xylem catches up with the needs of the leaves.

H. WILTING.



When plants are exposed to conditions in which they lose water to the atmosphere faster than it can be obtained from the soil, water is lost from the vacuoles. The pressure in the vacuoles drops and they no longer push out against the cell wall. The cells become flaccid. A plant structure made up of such cells would be weak and flabby. The stem would droop and the leaves would be limp. The plant is wilting.

Fig. 8.14

9. TRANSPORT IN MAN THE CIRCULATORY SYSTEM

A. BLOOD.

It is really a tissue made up of a liquid matrix, containing several types of cells. Half the volume of blood is plasma (fluid), the other half is blood cells.

-PLASMA: contains various salts + many plasma proteins. It transports the blood cells, ions, soluble food substances, hormones carbon dioxide, urea, vitamins.

- BLOOD CELLS: There are 3 main groups:

- R.B.C (Red Blood Cells). or ERYTHROCYTES
- W.B.C (White Blood Cells). or LEUKOCYTES
- PLATELETS or THROMBOCYTES

(SERUM = plasma - proteins involved in clotting.)

RED BLOOD CELLS



Are by far the most numerous cells in blood (+/- 4.5 million per microlitre (ml)). Their main function is OXYGEN TRANSPORT.

- Are round and bi-concave, mature RBC have no nuclei. They contain haemoglobin (protein that binds oxygen).
- Are produced from dividing cells in the bone marrow.
- Survive for +/- 4 months, then they break up and WBC destroy the remains by phagocytosis.

Fig. 9.1

WHITE BLOOD CELLS

- To protect the body from disease.
- There are different types of WBC:

Some are phagocytes (= cells that ingest bacteria, dead body cells...), others are involved in the immune response: they recognise antigens, they produce antibodies, and they control the immune response and afterwards "remember" it in some way.

WBC are also involved in tissue rejection (organ donation)

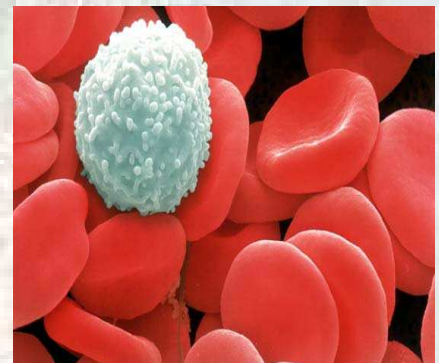
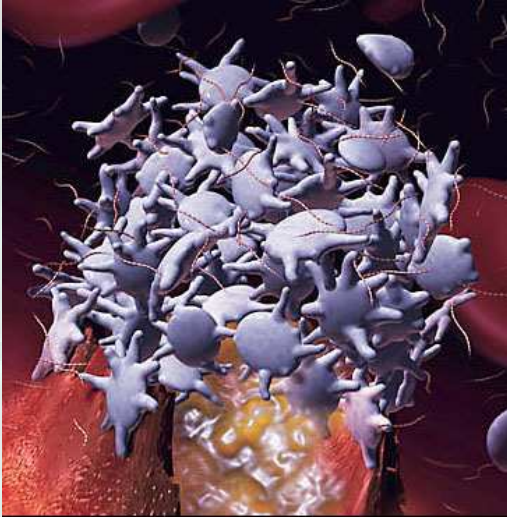

Fig. 9.2

PLATELETS

- are important in blood clotting. They are not really cells. They are parts of the cytoplasm of large cells in the bone marrow that pinch off.



Platelets are irregularly-shaped, colorless bodies that are present in blood. Their sticky surface lets them, along with other substances, form clots to stop bleeding.

When bleeding from a wound suddenly occurs, the platelets gather at the wound and attempt to block the blood flow. The mineral calcium, vitamin K, and a protein called fibrinogen help the platelets form a clot.

Fig. 9.3

BLOOD is used to transport ions, soluble food substances, hormones, CO₂, O₂, urea, vitamins, plasma proteins

B. THE MAMMALIAN CIRCULATION

- Arteries, capillaries and veins are the pipes through which blood travels to the tissues. Arteries are vessels that carry blood away from the heart. Their walls are muscular and highly elastic. They branch and re-branch into smaller arterioles which divide even further into capillaries.

- Capillaries are so narrow that RBC must pass through them in single file. Their walls are only one cell thick (it's here where substances are exchanged between blood and the extra-cellular fluid). Their far ends rejoin to form larger vessels called venules, and these combine to form veins; vessels leading back to the heart.

- Vein walls contain connective tissue and muscle as do those of arteries, but veins are much less elastic, and tend to have larger internal diameters.

C. DIFFERENCE BETWEEN VEINS and ARTERIES.

Veins:

- return blood from tissues to the heart
- carry de-oxygenated blood (except pulmonary vein)

Created by Bernard Brochez

- the blood pressure is lower because the blood passes first through the capillaries.
- they contain valves, flaps of tissue that help the one-way flow of blood. The valves
- open under pressure of blood flowing towards the heart, and close when it begins to go backwards.

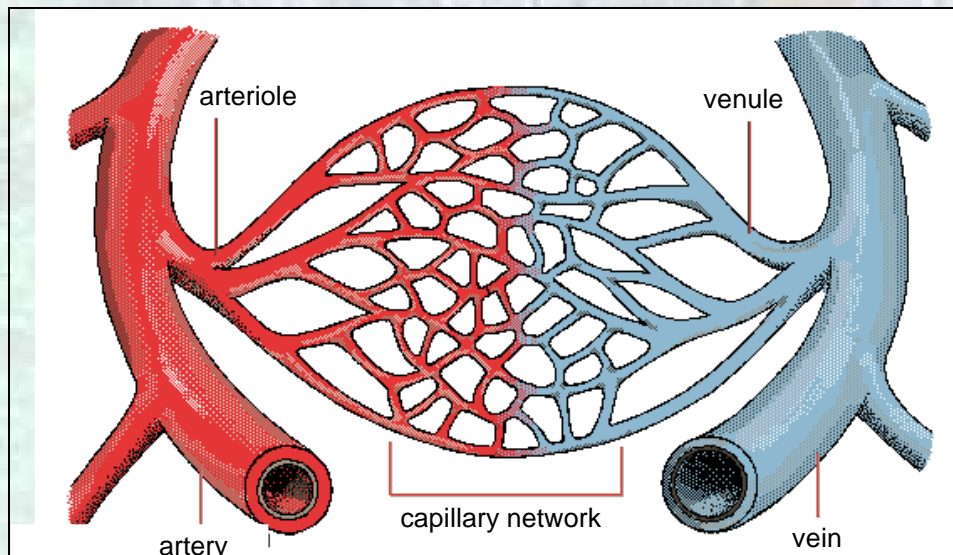

Fig 9.4

[The heart also has valves for the one-way flow of blood. These are found between atria and ventricles].

Arteries:

- Wide vessels, which carry blood from the heart to different organs.
- Have thick walls to resist the high blood pressure. The walls are also elastic and muscular so that the arteries can expand.
- Carry oxygenated blood (except pulmonary artery).

Capillaries.

- Tiny, small vessels.
- Very numerous (so: good contact with body cells).
- Oxygen, glucose, A.A. pass easily through the thin capillary walls into the body cells.
- Carbon-dioxide and waste products can diffuse back ---> are taken to the heart.

D. The circulation of blood in the body.

Blood returns to the heart from the body via 2 large veins: the VENAE CAVAE, it flows through the right atrium and goes to the right ventricle. Contraction of the R.A. sends

Created by Bernard Brochez

more blood in. The R.V. contracts and sends the blood through a valve into the PULMONARY ARTERY which goes to the lungs.

In the lungs, blood flows through capillaries, surrounding the alveoli (= air sacs of lungs). Blood picks up oxygen and gives off carbon-dioxide across the thin walls of the alveoli and lung capillaries. Then the blood goes through the PULMONARY VEINS back to the heart into the L.A. and passes through a valve into the L.V. The walls of the left ventricle are more muscular than those of the R.V. It must push the blood throughout the entire body, not just on the short journey to the lungs. The blood goes from the L.V. through the AORTA (main artery of the body). The aorta branches out into arteries, which take blood to the wall of the heart itself (coronary arteries), to the head (carotid arteries) and the rest of the body.

SO: there is a dual circulation!

1. Low pressure circ.: from heart to lungs = pulmonary circ.
2. High pressure circ.: from heart to body tissues = systemic circ.

MAIN BLOOD VESSELS IN THE MAMMALIAN BODY.

VENA CAVA: } *superior*: from head to heart
 } *inferior*: from body to heart

PULMONARY ARTERY: from heart to lungs

PULMONARY VEIN: from lungs to heart

AORTA: from heart to body (heart, head, digestive system, kidneys ...). The aorta branches out near its base.

HEPATIC PORTAL VEIN: takes blood from the ileum to the liver; it carries plenty food nutrients absorbed by the villi of the ileum.

RENAL ARTERY: carries blood from the aorta to the kidneys

RENAL VEIN: takes purified blood back to the heart via the venae cavae. (The urine passes down a collecting duct)

E. THE HEART.

Is really 2 pumps joined side by side. Each pump is made of a thin-walled atrium, which receives blood from veins and which pumps it into the adjoining ventricle, and a thick-walled ventricle, which pumps blood into arteries.

Created by Bernard Brochez

Right side of the heart receives blood from the body and pumps it to the lungs.
Left side of the heart receives blood returning from the lungs and pumps it to the rest of the body.

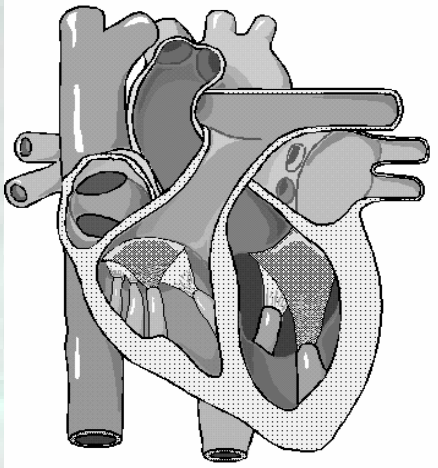

Fig 9.5

The heart is made up of special involuntary muscles, the cardiac muscles. Its size is about the size of your own fist.

The heart beats continuously throughout an animal's life. A normal heart beat is about 70- 80 beats/min. It can however increase up to 160 beats/min, if you're running, sporting...

When the muscles relax, blood flows into both the right and left atrium from the venae cavae and pulmonary vein respectively.

Then blood flows down into the ventricles (it passes valves) When the ventricles are full of blood, the heart muscles contract and blood is pushed into the pulmonary artery and the aorta. Then the muscles relax to start a new cycle.

In the heart, many valves prevent the back-flow of blood.

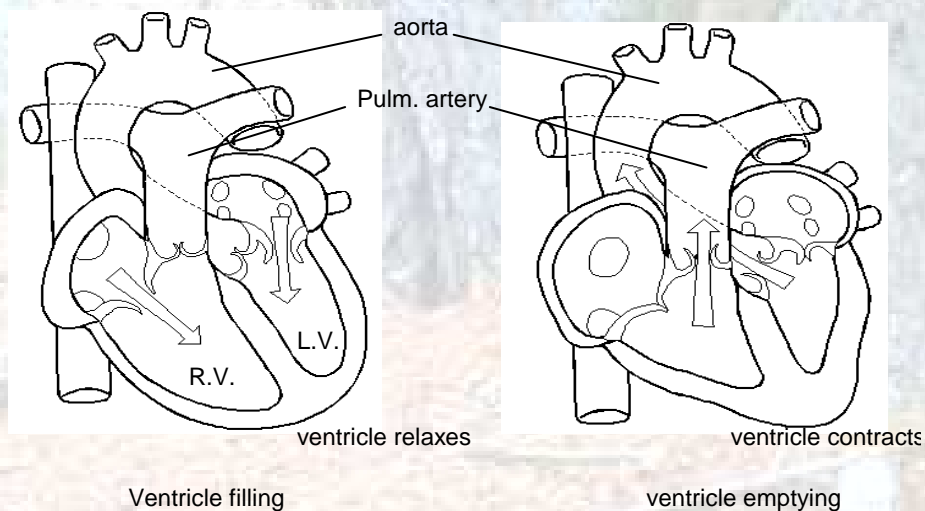

Fig. 9.6

Created by Bernard Brochez

F. PULSE POINT.

A point on the surface of the body where you can feel blood pumping through the arteries.

E.g. wrist, neck, ankle

Count your own pulse rate in class for 15 seconds and multiply by 4.

Effect of physical activity.

Running, heavy exercises make the muscles scream for more oxygen as to burn more glucose to get enough energy. Consequently, more blood will flow to the heart, muscles and trunk. The heart beat and the pulse rate will increase.

The longer you exercise, the more oxygen is used, and the faster the blood will have to take more oxygen back up.

Count your pulse rate after cross-country with intervals of 2' (160 → 120 → 100 → 80).

Normal Resting Pulse Rates	
Age	Pulse Rate (beats/min)
Birth	70-170
Neonate	120-140
1 yr.	80-140
2 yr.	80-130
3 yr.	80-120
4 yr.	70-115
Adult	60-100
Athlete	~50

G. CORONARY CIRCUIT.

- Is much smaller, but no less important.
- Serves the heart itself.
- 2 coronary arteries branch from the aorta near its base and circle the heart. From them branch many smaller arteries which go into the walls of ventricles and auricles (= Atria) where they divide up into capillary complexes. These complexes come together to form veins from which most of the blood reaches the right auricle; it mixes with the venous blood from the venae cavae and it goes to the lungs for oxygen-uptake and carbon-dioxide-waste.

Created by Bernard Brochez

So: heart cells receive food and oxygen from the small intestines (via the venae cavae) and lungs (via pulmonary vein).

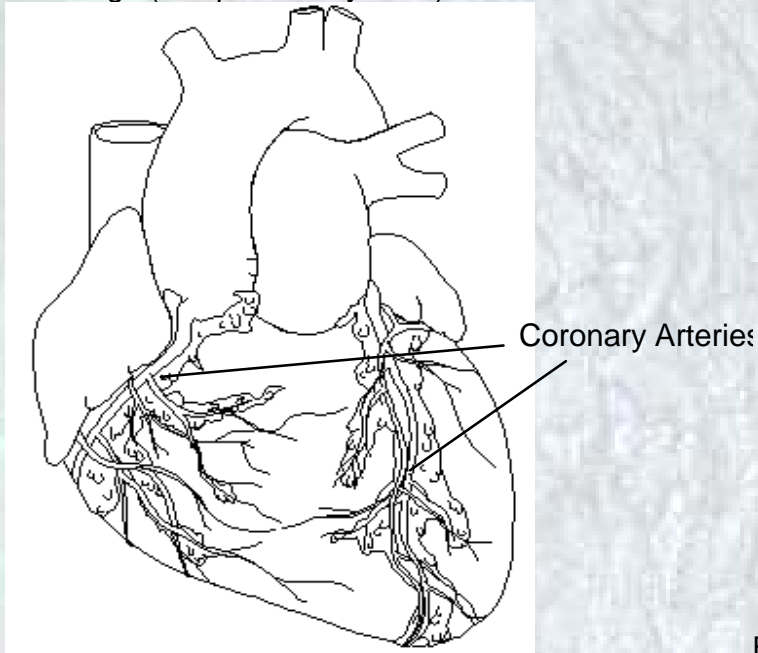

Fig 9.7

CORONARY HEART DISEASES.

Diseases which affect the heart and blood system.

a) Heart attack.

Occurs when the blood supply to part of the muscles that make up the heart fails. Without enough blood supply, the cardiac muscles stop contracting and may die.

One of the heart's arteries may become blocked by:

1. A thrombus = blood clot formed in the vessel itself.
2. An embolus = blood clot formed in another vessel and carried with the blood to the heart.

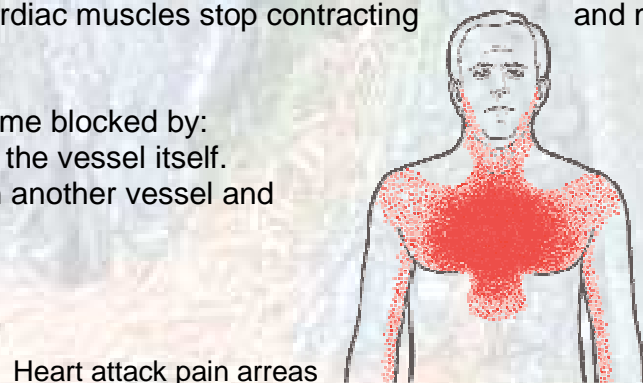

Heart attack pain areas

Fig. 9.8

Created by Bernard Brochez

b) Atherosclerosis.

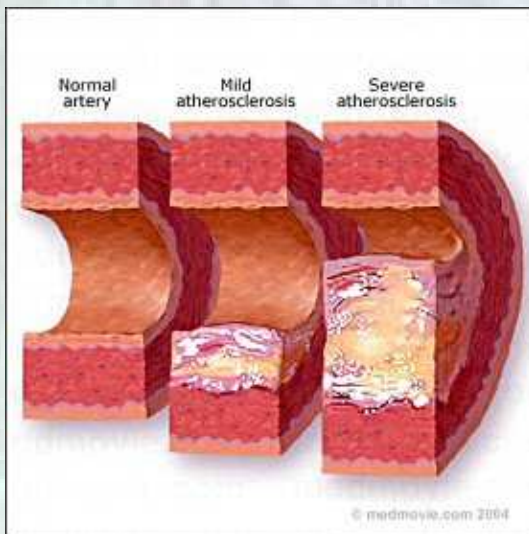

The artery walls become thickened and the passageway for blood gets narrowed, by the growth of cells and deposits of lipids and other materials.

Fig. 9.9

c) Stroke.

Occurs when the blood supply to some part of the brain is damaged. The brain cells deprived of blood get no more oxygen and can die. It can result from a blood clot or from the rupture of a weak blood vessel. Its severity depends on what part of the brain is affected.

Fig. 9.10

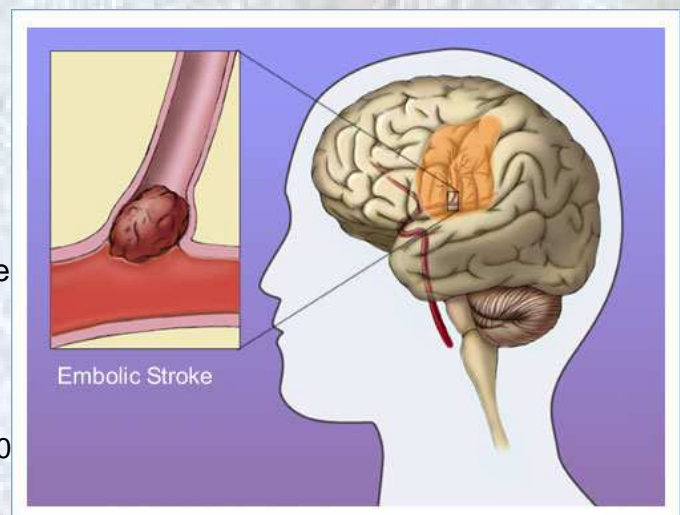

CAUSES:

- Diet (too much fat, salt,...)
- Drinking alcohol in big quantities.
- smoking
- stress combined with a sitting life (at a desk)

Since 1985, people are more aware, take more care of their diet, do more exercises like jogging, cycling.

Even food industries produce "light" products with less fat, less cholesterol....
(diet coke, light coke...)

H. TRANSFER BETWEEN CAPILLARIES AND TISSUE FLUID.

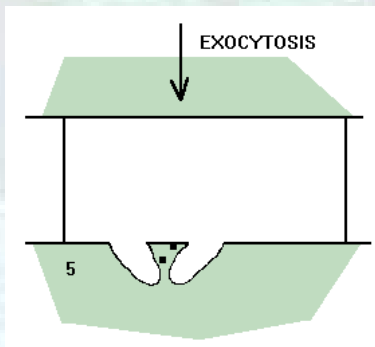
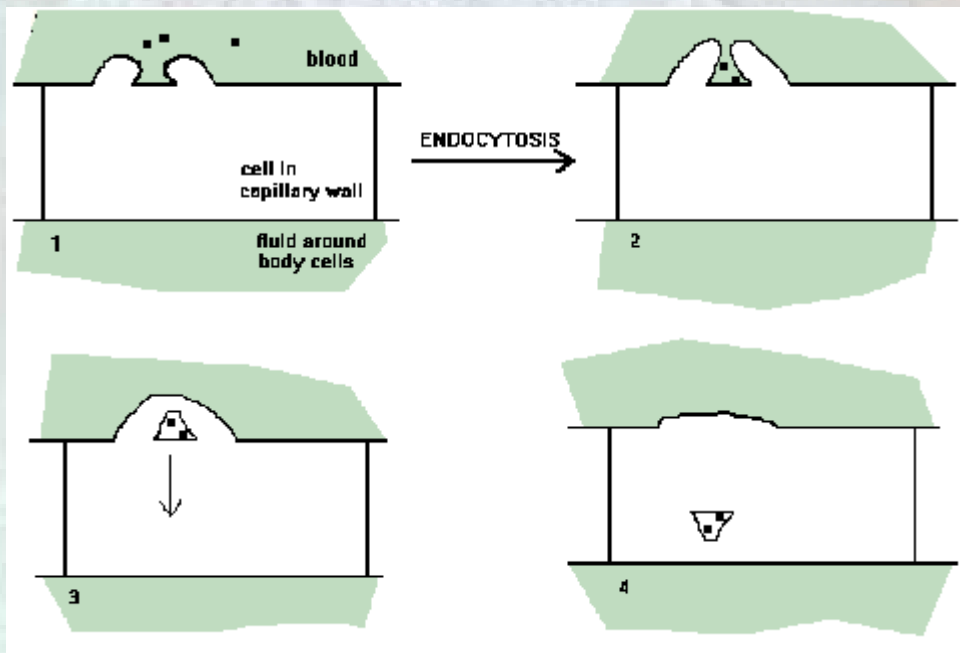

Glucose and oxygen leave the blood for the extra-cellular fluid by diffusing down the concentration gradient between the two fluids.

- Waste products and carbon-dioxide return to the blood in the same way.

Fig 9.11

- Water and larger molecules (hormones, proteins...) enter and leave the blood by moving through spaces between the cells of the capillary walls or by passing through the cell itself by way of endocytotic vesicles.

I. BLOOD CLOTTING.

The process starts when the wall of a blood vessel is damaged or broken. The injured cells release substances that attract blood platelets to the site. Here, they disintegrate and form a temporary plug for the injured vessel.

They also release 2 substances; one causes the muscles in the blood vessel wall to contract, so that the vessel closes.

The other substance makes that the plasma-protein Fibrinogen changes into Fibrin. Strands of fibrin form a meshwork around the disintegrated platelets.

Finally a tough, hard plug or clot seals off the injured part.

Created by Bernard Brochez

J. HUMAN BLOOD GROUPS.

People have different bl.gr. because their DNA (genes) code for different. blood-proteins.

The most famous blood-proteins are those of the A,B,O and Rh series, but there are many others.

BL.group	antigen on RBC membrane	antibody in plasma
A	A	anti-B
B	B	anti-A
AB	A and B	neither
O	neither	anti-A and anti-B

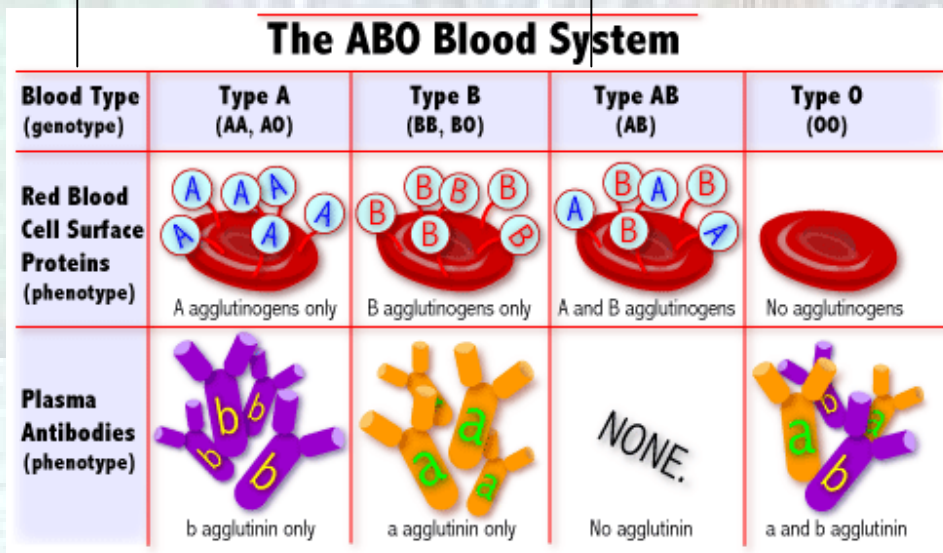

Fig. 9.12

An antigen and antibody stick together. Anti-B antibodies cause type B-RBC to agglutinate or stick together. So, the blood becomes useless.

For a blood transfusion, ABO blood groups must be compatible between donor and recipient. If not the blood cells will agglutinate and block some vessels.

e.g. O + transfusion with A

The A red blood cells encounter anti-A antibodies in the type O plasma. The A RBC stick together and block some vessels.

Created by Bernard Brochez

So, before a transfusion: blood of the 2 persons will be mixed on a glass slide to see if there is no agglutination.

Rhesus - BLOOD GROUPS.

Are different from ABO groups in that the ABO antibodies are always present in the blood, whereas Rh antibodies are produced only when foreign Rh antigens enter the body.

Rh +: Rh antigen on RBC

Rh -: no Rh antigen on RBC

A Rh - person given a transfusion with Rh+ blood will develop anti-Rh antibodies over a 2 to 4 month period. Any Rh+ blood that subsequently enters his body will agglutinate.

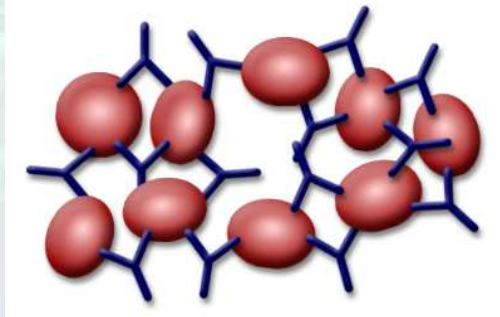

This is of great importance for pregnant Rh- mothers, carrying a Rh+ baby. During birth, some of the baby's blood may enter the mother's circulation.

Fig. 9.13

She will make antibodies. If she then gets pregnant again of a Rh+ baby, her anti-Rh antibodies will diffuse across the placenta into the foetus, where they will cause the blood cells to agglutinate. The foetus may die.

Since Rh- blood is less frequent, a Rh- girl is most likely to marry a Rh+ man.

Just after birth, a Rh- mother will be given an injection of anti- Rh antibodies, to remove any Rh factor that may have entered her blood. In this case, the mother herself is not making the antibodies, so there will be no memory of the immune system, and she can get pregnant again without worries.

This is also the reason why a Rh- person is called a UNIVERSAL DONOR

10. RESPIRATION.

Living cells require a constant supply of energy-intermediates to drive their energy-requiring activities: muscle contraction, protein synthesis, active transport and cell division, to name a few.

All organisms can make energy intermediates such as A.T.P.(Adenosine Tri-Phosphate), by breaking down organic food molecules, usually glucose and other carbohydrates.

The breakdown of food to release Energy occurs by two kinds of processes:

RESPIRATION
and **FERMENTATION**.

A. CELLULAR RESPIRATION .

= Stepwise oxidation of food molecules using an inorganic substance as final electron-acceptor.

Respiration is usually **AEROBIC** (= using or requiring molecular oxygen, O₂)

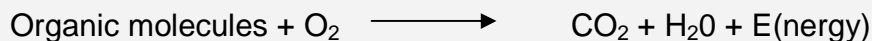

The same equation applies also to the combustion, or burning, of wood or paper. Combustion, however, oxidises the organic molecules all at once!!!

Respiration oxidises food in a series of controlled steps, each releasing a little of the food molecule's energy. This permits cells to capture more energy in the form of energy - intermediates than they could if the energy were released in one big burst.

The energy released is used for muscle contraction, protein synthesis, cell division, active transport, growth, passage of nerve impulses, and the maintenance of a constant body temperature.

B. ANAEROBIC RESPIRATION.

Some cells live in anaerobic conditions, where there is no oxygen, or where it is sometimes in short supply. Some kinds of bacteria carry out the unusual process of anaerobic respiration. They use other inorganic substances such as nitrate (NO₃⁻) or sulphate (SO₄²⁻), instead of O₂ as final electron acceptor.

Created by Bernard Brochez

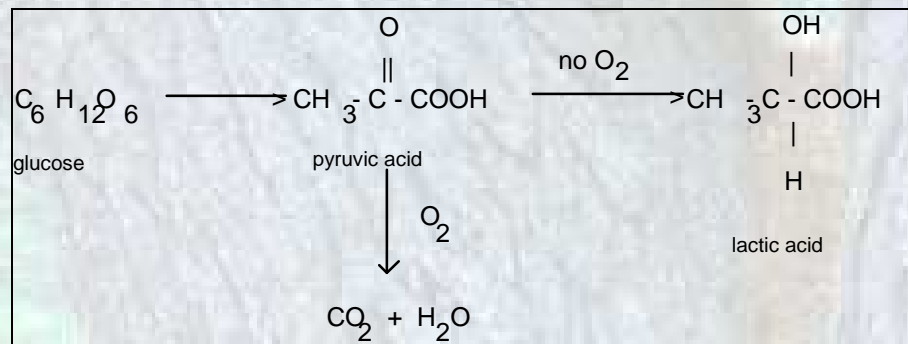

Fig. 10.1

Glucose in this case is not broken down completely, but it is changed into lactic acid or alcohol. Since the breakdown is not complete, there will be less energy available. The breakdown of glucose starts anaerobically (without O_2 !!!!)

C. Production of lactic acid in muscles.

Muscle cells take in Glucose (G) from the bloodstream. They can also, like the liver, convert some of the G to Glycogen. When E is needed, Glycogen is converted into G again.

Glucose ----> Pyruvic acid + Little E (in the presence of oxygen, the P.A. will be broken down and the E stored in ATP.)

Pyruvic acid can only be broken down completely with O_2 !!!

How does muscle fatigue happen?

When a muscle fibre runs short of O_2 , it continues to change Glycogen to glucose to P.A.

Since no oxygen is present, the P.A will be converted to L.A., which will accumulate and affect the muscle fibre.

- L.A. changes the pH (muscle fibre will not be able to respond any more).
- L.A. blocks the fibre's further activity.

The L.A. accumulates and begins diffusing out of the muscle fibres into the bloodstream. When oxygen is available again, the liver will take the L.A. from the bloodstream and convert it back to Glycogen. The muscle cells are now ready for action again.

Created by Bernard Brochez

D. Gaseous exchange in Man.

Associated structures.

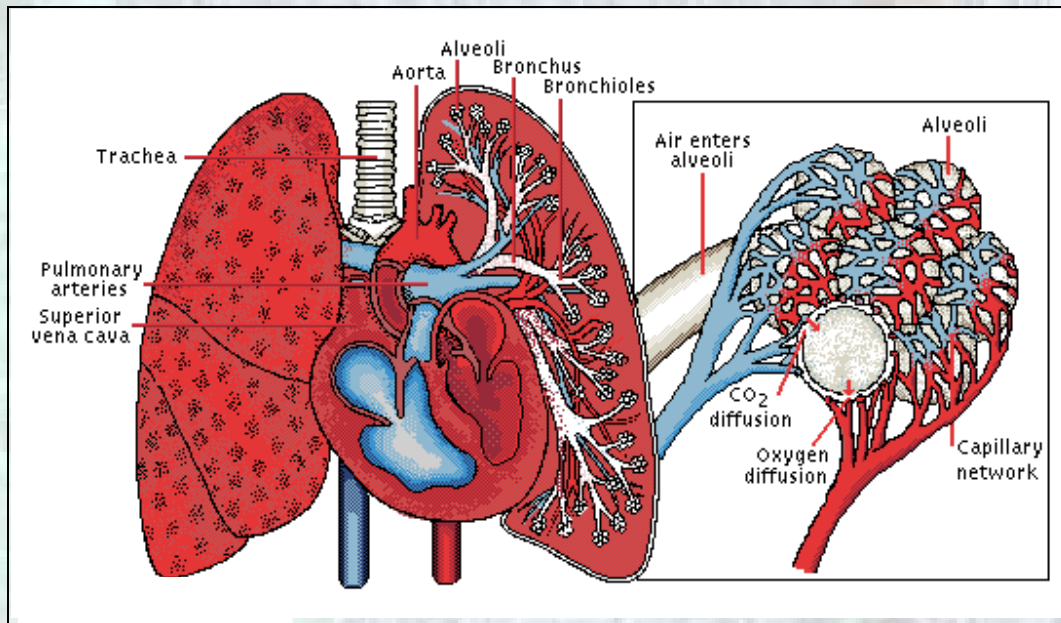

Fig 10.2

Air travels from the nose or mouth to the lungs by way of air passages: trachea, bronchi and bronchioles. The actual respiratory surfaces are the walls of the numerous alveoli in the lungs.

The lining of the alveoli is covered with a film of moisture. The oxygen concentration in the blood is lower than in the alveolus, so the oxygen in the air space dissolves in the film of moisture and diffuses through the epithelium, the capillary wall, the plasma into a RBC, where it combines with the haemoglobin.

The capillaries reunite and form the pulmonary vein, which goes back to the heart (left atrium).

The low concentration of CO₂ in the alveoli stimulates an enzyme in the blood to break down the bicarbonate salts and liberate carbon-dioxide. This diffuses into the alveoli and is expelled.

Much air stays in the alveoli, even during maximum exhalation. This residual air keeps the moist walls of the alveoli from sticking together, or collapsing.

Created by Bernard Brochez

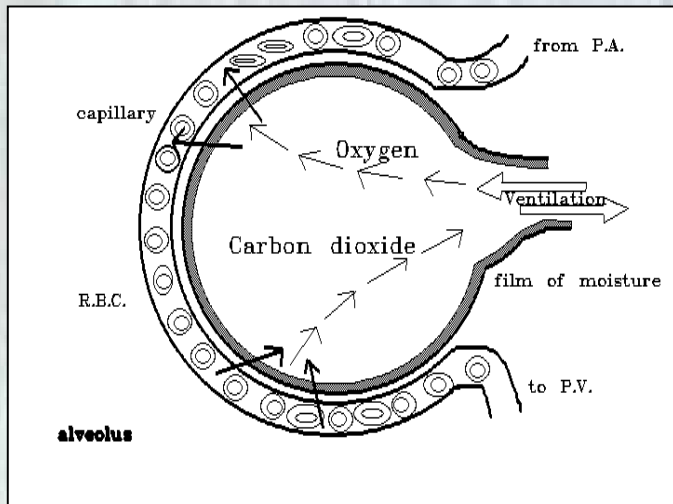

Fig 10.4

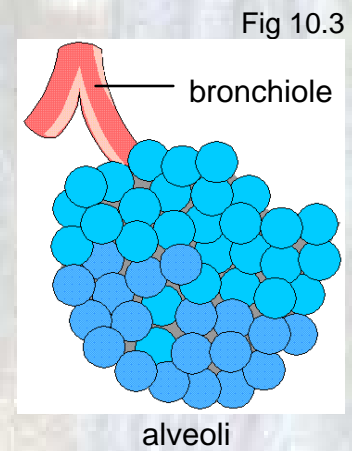

Fig 10.3

E. Composition of inspired & expired air.

	INSPIRED	EXPIRED
Oxygen	21 %	16 %
Carbon dioxide	0.04 %	4 %
Nitrogen gas	79 %	79 %
Water vapour	varies	saturated

Nitrogen dissolves in the blood plasma but it plays no role in chemical reactions of the body.

F. The action of breathing.

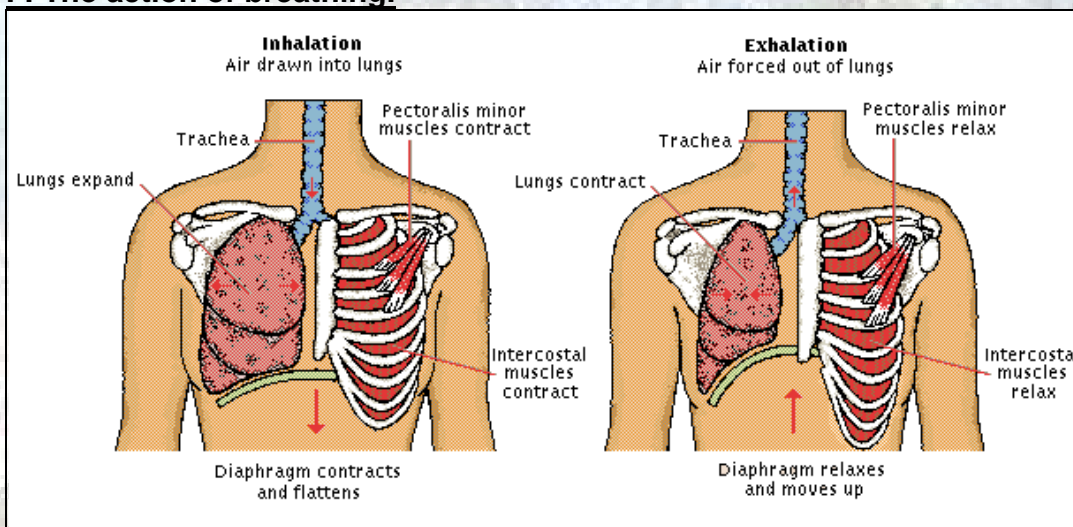

Fig 10.5

Created by Bernard Brochez

G. The rate of breathing.

The breathing movements (diaphragm, intercostal muscles), are carried out without us being aware.

A small area of the brain is sensitive to the concentration of CO_2 in the blood. If the conc. increases, the area will be stimulated. As a result, the brain will send more nerve impulses along the motor neurones to the rib muscles and diaphragm. Air is inhaled and exhaled more rapidly. The concentration of carbon-dioxide will decrease; the brain will no longer be stimulated and breathing is restored to normal.

During heavy exercise (cross-country) the concentration of carbon-dioxide in the blood will rise. As a consequence, the breathing rate will increase, as well as the depth of breathing. Otherwise, the CO_2 would accumulate.

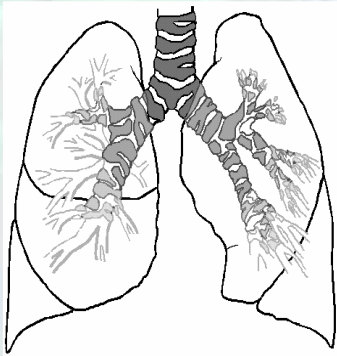

Fig 10.6

11. SUPPORT, MOVEMENT AND LOCOMOTION.

The Skeleton.

The skeleton of Man consists of 206 bones.

Most of our skeleton lies under muscles. We therefore call it an **ENDOSKELETON**. (Endo = inside)

Arthropods (crabs, lobster, Scorpio...) have a skeleton on the outside of the body. The muscles are found inside the skeleton. We call this an **EXOSKELETON**. (Exo = outside).

Our skeleton has two major portions:

• **Axial Skeleton:** along the axis of the body.

This consists of the skull + bones of the head, backbone, ribs, sternum (breastbone) and tail.

• **Appendicular Skeleton:** This consists of bones in the limbs and girdles which attach the limbs to the backbone.

- Pectoral girdle: collarbones + shoulder-blades.
- Pelvic girdle: large fused hipbones (ilium, ischium, pubis)

A. Cartilage, Bone and Muscle

All these tissues are made by living cells, though bone and cartilage do contain some non-living components.

Cartilage:

This occurs in several forms:

* **One form is firm and semi-transparent.**

- It makes up the rings which keep the trachea and bronchi open.
- It covers the surfaces of movable joints, reducing friction and wear.
- It supports that part of the nose which protrudes from the face.

Created by Bernard Brochez

* Fibrous cartilage

- Contains many fibres as well as living cells. This cartilage is elastic and flexible.
- It forms the external ear pinna and the epiglottis.

* Fibro-cartilage

- is less flexible but has very strong fibres.
- contributes to some ligaments and attaches tendons to bones.
- it also forms part of inter-vertebral discs.

Bone:

Bone is a harder tissue than cartilage and less flexible. It contains living cells and non-living fibres.

The fibrous tissue between the cells becomes hardened by a deposit of calcium salts such as calcium phosphate.

Although bone contains a high proportion of non-living material it is penetrated by blood vessels which keep the cells alive and allow growth and repair to take place.

Muscle:

Muscle tissue has two distinguishing characteristics: **contractility** and **electrical excitability**.

Vertebrates (animals with a backbone) have three types of muscles:

- **Cardiac muscle:** makes up the heart
- **Smooth muscle:** lines the walls of many internal organs
- **Skeletal or striated muscle:** responsible for locomotion

Striated muscle is normally the only type of muscle under the animal's voluntary control (= You can move your hand, your legs... but you can't stop your heart beat).

B. Functions of the skeleton.

- It supports the body and gives it shape.
- It protects: the brain (skull).
the heart and lungs (rib cage).
the spinal cord (backbone or vertebral column).
- It takes care of locomotion by muscles which are attached to the bones by ligaments.
- It takes care of the production of blood cells (bone marrow). Some bone marrow is primarily a fat depot, but some marrow produces RBC, WBC, platelets, and antibodies.
- In vertebrates it helps regulate the concentration of calcium ions in the blood.

C. Joints in the vertebrate skeleton.

Joints can be of many different types and degrees of rigidity.

- Sutures: wiggly lines in the skull, which are very tight together.
- Most bones are joined to each other by **LIGAMENTS** (an extremely flexible joint in women is found between the two bones in front of the hip girdle = for giving birth).

Joints of limbs must permit smooth movement in various directions. Therefore, the ends of the bones in the joints are covered by a smooth elastic sheet of connective tissue (cartilage).

The whole joint itself is surrounded by a sac which is filled with synovial fluid. This fluid acts as a lubricant.

Mammals have four different types of bones:

- **Long bones:** have a long axis with a thicker portion (head) at each end (femur (thigh) and humerus)
- **Short bones:** spongy bones, covered with a layer of compact bone (carpals, metacarpals)
- **Flat bones:** sternum, scapula..
- **Irregular bones:** vertebrae..

D. The fore-limb of Man (the arm).

The whole arm of Man consists of:

- **Scapula (shoulder blade)**, which is loosely attached to the backbone for easy movement.
- The **humerus**, the upper arm bone, which has a long shaft with a head at both ends.
- The **radius and ulna** (lower arm bones).
- the **wrist and hand bones** (carpals and metacarpals).
- and the **fingers** (phalanges)

The radius and ulna articulate with the humerus at the elbow-joint and with the carpals at the wrist.

Radius and ulna twist around each other when the arm is turned
(Thumb inside \longleftrightarrow thumb outside).

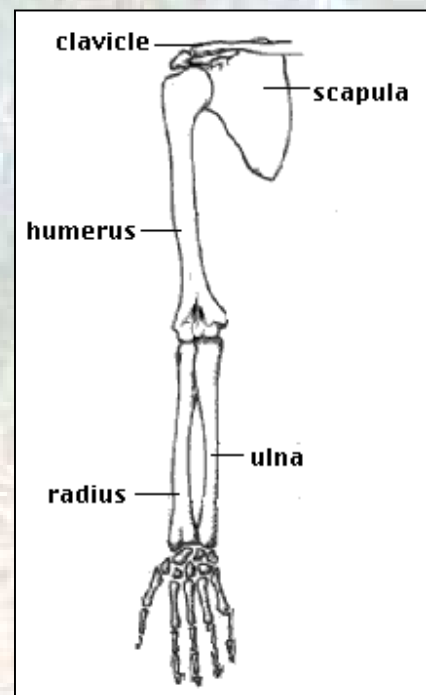

Fig. 11.1

Created by Bernard Brochez

a) Ball and socket joint.

This joint is found at the shoulder (scapula-humerus) and the hip (hip-femur)

The heads of the humerus and femur are large compared with the socket in which they fit. This allows for free arm and leg movement. The movement in the ball and socket joint is almost universal (360°). The joint is held in place by ligaments.

In the joint there is synovial fluid which is secreted and kept in the joint by the synovial membrane.

The synovial fluid is used to lubricate the joint.

The entire joint is surrounded by a capsule of fibrous material whose inner lining is the synovial membrane.

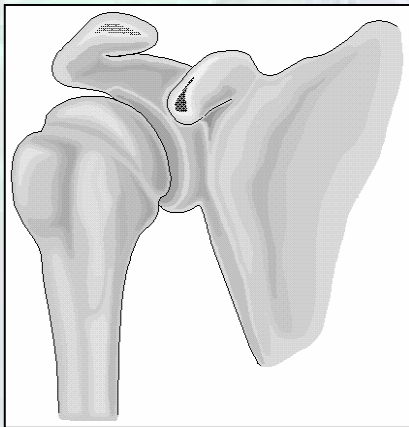

Fig 11.2

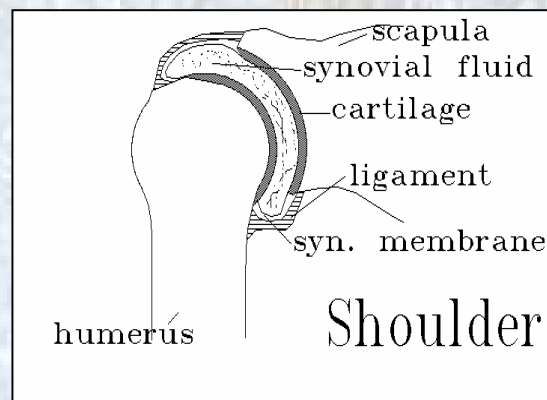

Fig. 11.3

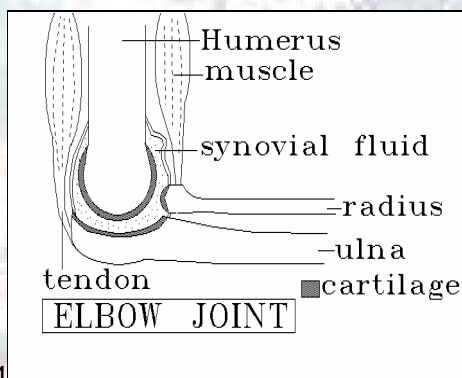

Fig. 11.4

Created by Bernard Brochez

b) Hinge joint.

This joint is found at the elbow (humerus-radius and ulna) and the knee (femur-tibia and fibula).

This joint allows movement only in **ONE** plane. It has greater power though and there is less danger of twisting.

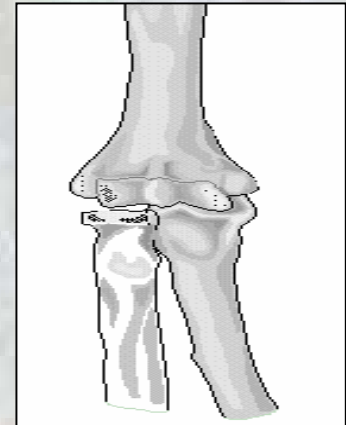
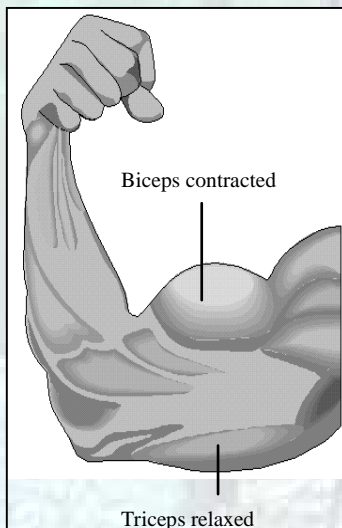

Fig. 11.5

E. Antagonistic Muscles.

Antagonistic muscles are working at hinge joints. These muscles are found in two sets and they have opposite effects.

Example: the biceps and triceps:



- When the biceps contracts, the triceps are being stretched and the forearm is being lifted. We call this action: **FLEXION**.
- When the triceps contracts, the biceps are being stretched and the entire arm is being stretched. We call this action: **EXTENSION**.

Fig. 11.6

The biceps muscle is therefore called the flexor muscle, and the triceps, the extensor muscle.

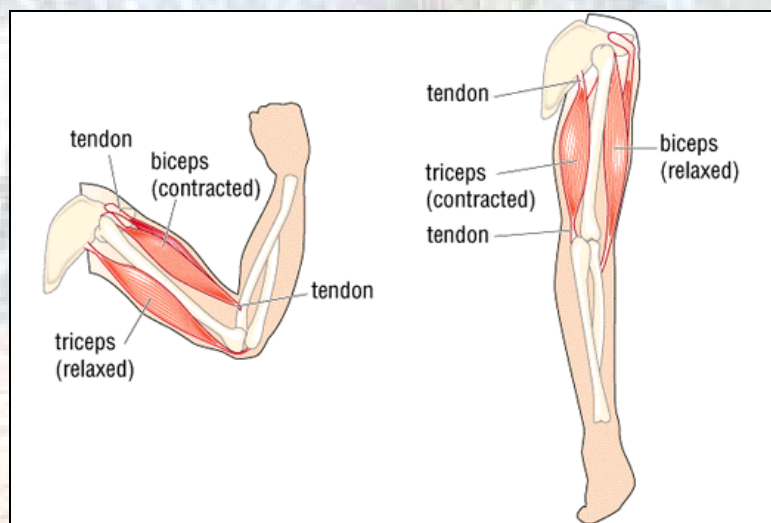

Fig. 11.7

Created by Bernard Brochez

The muscles are attached to the skeleton by **tendons** at their **insertion** (= the end of the muscle attached to the bone that moves) and **origin** (the end of the muscle attached to the less mobile bone).

In some other cases, the skeletal muscles are also attached directly to the skeleton.

Some other joints found in our skeleton are:

- **Fixed joints:** e.g. between bones of the skull (no movement)
- **Gliding joints:** where the bones glide over one another. E.g. Wrist bones, anklebones.
- **Pivot joint:** where one bone pivots on another. E.g. atlas and axis bone ---> head turns L. to R.

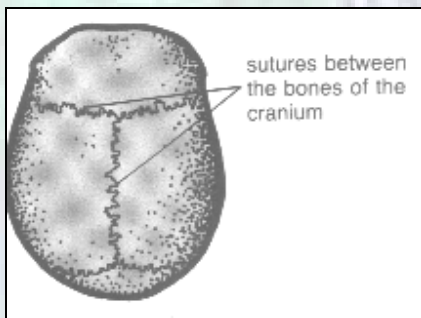

Fig. 11.8
Fixed joints in the skull



Fig. 11.9
Gliding joints in the wrist region

12. EXCRETION

Is the removal from the body of:

- waste products of chemical processes which take place in the body.
- substances taken in with the diet, in excess of the body's needs.
- potentially harmful substances taken in with the food or in the form of drugs.

The chief wastes produced by the body are CO_2 and H_2O from the breakdown of organic molecules, and nitrogenous wastes from breakdown of proteins.

CO_2 is excreted across the respiratory surfaces of the body.

Excretory organs (like kidneys) have TWO major functions:

- Removing nitrogenous wastes
- Regulating the body's salt and water contents.

In addition, excretory organs control the body's content of substances like spices, drugs and hormones, which occur in lesser amounts.

Onions, garlic and some other spices have volatile components that leave the body through the lungs. Other parts of the same spices are excreted through the kidneys. Penicillin and other drugs are removed from the system primarily via the kidneys. Kidneys, liver and lungs carry out detoxification, altering substances to forms that are not poisonous to the body.

TABLE 1.

<u>SUBSTANCE EXCRETED</u>	<u>EXCRETORY ORGAN(S)</u>
Nitrogenous wastes	Kidneys Skin (small amount in sweat)
Water	Kidneys Skin
Salts	Lungs Kidneys Skin (in sweat)
Carbon-dioxide	Lungs
Spices	Lungs Kidneys

Created by Bernard Brochez

NOTE: Undigested food from the gut is not in our list. Food that leaves the body through the anus is EGESTED, that is, it travels through and is expelled from the body without ever passing a plasma membrane, to become part of the body.

THE TERM EXCRETION IS CORRECTLY APPLIED ONLY TO SUBSTANCES THAT MUST CROSS PLASMA MEMBRANES TO LEAVE THE BODY.

A. How excretory organs work.

Any excretory organ does **THREE** things:

- It collects fluids from somewhere inside the body, usually from the blood or from spaces between organs.
- It modifies the composition of this fluid by resorbing substances the body needs to retain, or by active transport of waste substances into the excretory product.
- It provides some means of expelling the excretory product from the body.

We see these 3 features even in the contractile vacuoles of single-celled protozoan.

During excretion, an organism expends metabolic energy. First, it uses E in the breakdown of proteins and in the formation of urea or uric acid. Secondly, E is used in the active transport mechanisms.

About 10 % of the human body's E is spent just to move blood to the kidneys and to purify it.

B. Removal of CO₂ from the lungs.

See also the chapter Respiration.

When cells respire they produce CO₂. Through the extra-cellular fluid it passes into the blood stream, which takes it to the lungs. There it diffuses out into the alveoli and is finally taken out when the person is exhaling.

C. Removal of water from the body.

Water is produced by the cells when they respire

Glucose + Oxygen -----> Carbon-dioxide + Water + E

Water is also taken into the body with the food we eat.
Some of this water will have to be excreted.

The water gets into the bloodstream from respiring cells and from absorption from the large intestines. Part of that water reaches the alveoli with the blood and is exhaled as water vapour. Another part reaches the skin and is lost from the body by sweating. The biggest part of the water will eventually reach the kidneys. How much water subsequently will be excreted depends upon the concentration of the blood.

The body may detect a decrease in its water content in one of two ways:

- 1) Either as a reduction in blood volume (e.g. severe bleeding) or
- 2) as a decrease (greater negativity) in the osmotic potential of the blood due to the loss of water (e.g. from sweating)

(Osmotic potential = tendency to gain water.)

VASOPRESSIN (= **A.D.H.** = **Anti-Diuretic Hormone**) is a hormone released from the posterior pituitary gland in the brain. Its presence in the blood increases resorption of water from the urine (urine becomes more concentrated and is darker in colour)

- If the blood is too concentrated (this is measured in the hypothalamus), A.D.H. will be secreted. When this hormone reaches the kidneys, it causes the kidney tubules to absorb more water from the glomerular filtrate back into the blood. The urine becomes more concentrated.
- If the blood is too dilute, secretion of A.D.H. is suppressed and less water is absorbed from the filtrate.

D. How urea is removed .

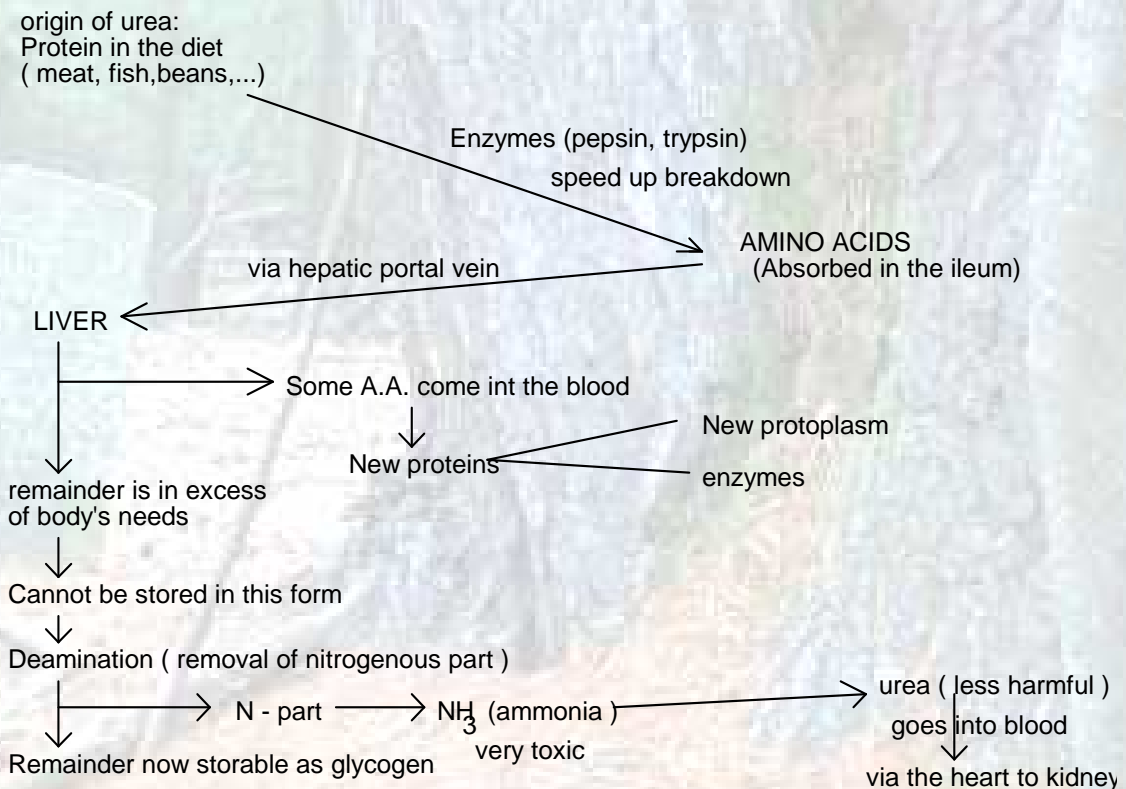

Fig. 12.1

Created by Bernard Brochez

E. Function of the different parts of the excretory system.

KIDNEYS: fairly solid organs, oval in shape.

- Are red-brown in a transparent membrane.
- Are attached to the back of the abdominal cavity.
- Blood is supplied by the renal artery, and the renal vein takes the deoxygenated blood away to the vena cava.

Function: to remove urea and excess water from the blood.

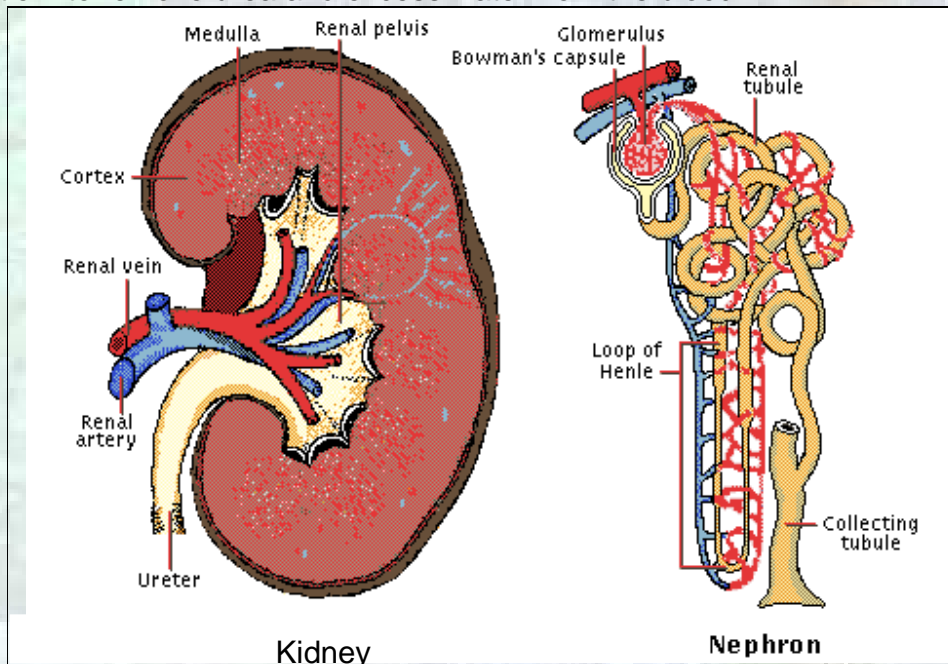

Fig. 12.2

URETERS: collecting ducts, starting from the kidneys.

Take away the urine from the kidneys and lead it into the urinary bladder.

URINARY BLADDER: extensible sac with elastic and muscular tissue in its walls.

It collects urine and stores it. Water may be resorbed from the bladder under appropriate hormonal conditions.

A sphincter muscle closes the outlet to the urethra.

When the sphincter relaxes, the bladder contracts, helped by the muscles of the abdomen.

URETHRA: A tube from which the urine is expelled from the body.

F. Dialysis in kidney machines.

When the kidneys are not functioning properly, waste products collecting in the blood would poison the body.

Created by Bernard Brochez

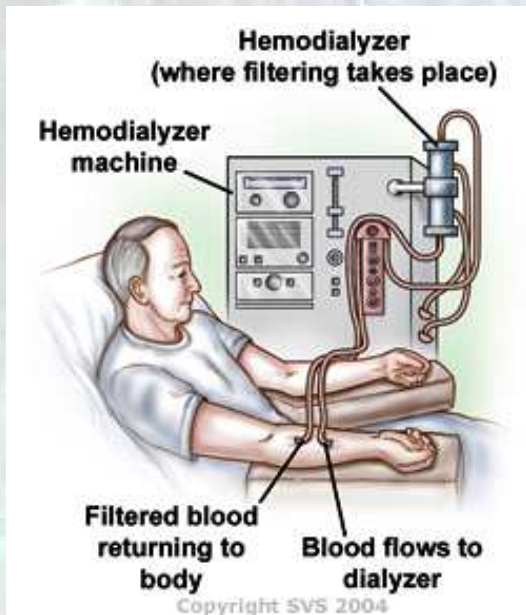

Two tubes are connected to the patient's arm: one is connected to an artery and it carries blood from the patient to the kidney machine; the other one is connected to a vein and carries "cleansed" blood from the machine back to the patient.

The kidney machine itself consists of pumps and mixing chambers to pump the blood and mix the dialysate bath (Bathing fluid) properly.

The dialyzer or artificial kidney consists of a semi-permeable membrane that permits diffusion of some substances across it (urea and creatinine) but not others (blood cells)

Fig. 12.3

The dialysate bath in the machine contains a solution of substances or chemicals normally found in the body: salts, calcium and magnesium as examples. The chemicals in the solution are in lower amounts than in the body.

The patient's blood circulates and chemicals move from the patient (high) through pores in the membrane and into the dialysate (low) and are then disposed of.

A kidney machine does not duplicate all of the normal kidney's functions!

Hemodialysis employs the process of diffusion across a semi-permeable membrane to remove unwanted substances from the blood, while adding desirable components.

A constant flow of blood on one side of the membrane and a cleansing solution on the other, allows removal of waste products in a fashion grossly similar to that of the glomerular filtration.



Fig. 12.4

Created by Bernard Brochez

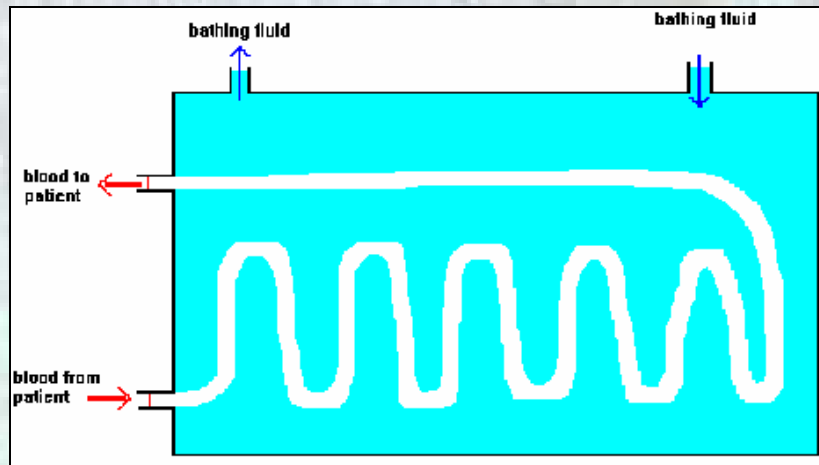

Fig. 12.5

By altering the composition of the dialysate, the method of exposure of blood and the dialysate; patients without renal function can be maintained in a relatively healthy state.

Most patients require between 10 and 15 hours of dialysis per week, divided into several sessions. The time depends upon body size, residual renal function, dietary intake, complicating illnesses....

13. HOMEOSTASIS

= The maintenance of conditions inside the body within the narrow limits required for life.

Homeostasis literally means “**Staying the same**”, which includes regulation of temperature, of pH, and of the amounts and proportions of salts and water.

Homeostasis is very important:

- People change their diets during daytime. One meal may include a large amount of sugar, with very little in the next meal. Yet, the amount of sugar in the blood is almost the same throughout the day.
- During heavy exercise, large amounts of oxygen are needed and plenty carbon-dioxide is released, and yet the oxygen and carbon-dioxide levels in our blood do not vary greatly.
- The temperature outside the body can change greatly, but our internal temperature stays constant: +/- 37 °C.

To control all this, many mechanisms have to be present. The **nervous system** and the **endocrine system** are the 2 systems most directly responsible for this control.

A. Temperature regulation in man.

Mammals have thermo-receptors consisting of free nerve endings. These are scattered over the surface of the body, particularly on the tongue. There are also internal thermo-receptors that detect internal body temperature in the hypothalamus of the brain. Information from internal and external thermo-receptors is integrated in the hypothalamus to produce appropriate behaviour (shivering, sweating...)

Mammals maintain high body temperature (35°C - 42°C). They do this by producing a great deal of metabolic heat and regulating the rate at which this heat is lost to the environment.

1. Temp. gets too high.

If the blood reaching the hypothalamus is a fraction of a degree higher than normal, a message (nerves) will be sent to the skin and the following will be the result:

- **Vasodilatation:** Arterioles will widen, so more blood will flow near the surface. Heat can be given off to the environment by convection and radiation.
- **Sweating:** Nerve impulses will be sent, to increase the rate of sweat production. Sweat glands are found in the dermis of the skin. A continuous layer of moisture will

Created by Bernard Brochez

be produced on the skin surface. Heat absorbed by the sweat will be lost since the sweat evaporates. Air movement over the skin helps in speeding up evaporation of sweat. In humid weather conditions, the air contains so much water vapour, which sweat may not evaporate rapidly enough. We get heat stagnation.

2. Temp. gets too low.

- **Vasoconstriction:** When the body is too cool, nervous and hormonal signals constrict the surface blood vessels and decrease the blood flow to the skin, reducing heat loss.

Extremities, such as ears, nose, and legs are often slim and streamlined with little insulating fat. We lose plenty of heat from the blood in these parts of the body. (E.g. legs of a bird fishing in an icy mountain stream).

- We cope with this difficulty by means of **counter-current-heat exchangers**, arrangements in which the blood vessels entering and leaving the ear or leg run next to each other. This allows blood traveling in the vessels to exchange heat with blood running in the opposite direction. Blood on its way to the limb gives up heat to blood returning to the body. By the time the outgoing blood reaches the limb it has been cooled, so that it has little heat left to lose to the environment. Its heat has been given up to the blood returning to the body. This blood has now been warmed almost to body core temperature.

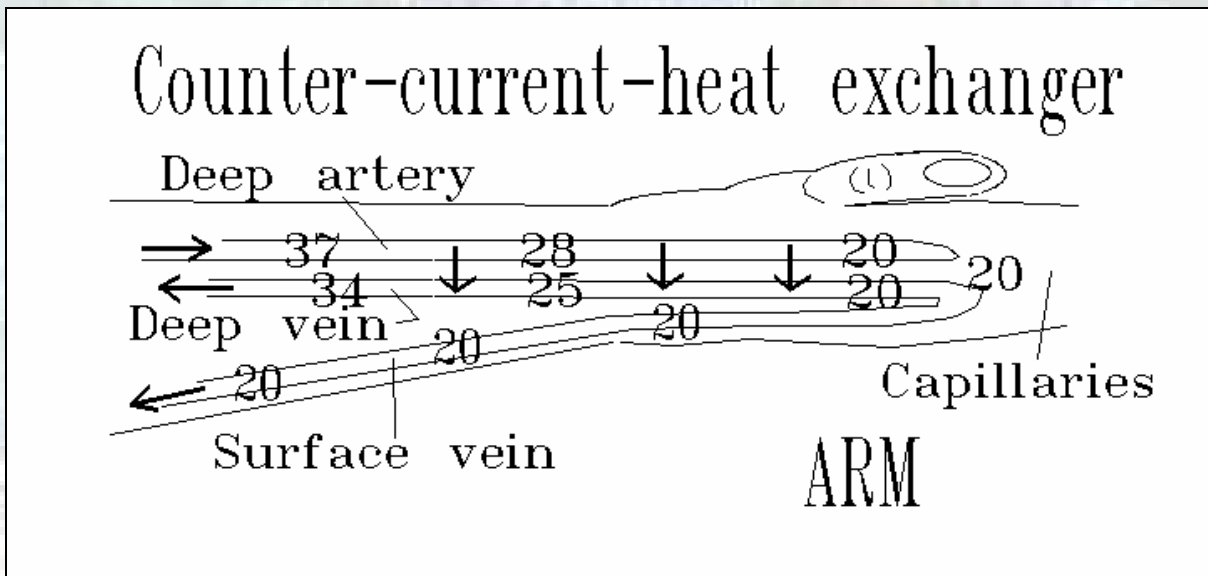

Fig. 13.1

When heat conservation is not needed, the heat exchanger can be bypassed, most of the blood will return via a surface vein.

The nervous system controls the degree of constriction of the 2 veins.

Created by Bernard Brochez

- **Shivering:** spasmodic contractions of muscles, which produce heat to help raise the body temp.
- **Metabolism** will increase: rate of chemical changes in the body is increased, particularly in the liver ---> releases more heat.

B. The skin.

There are two main layers in the skin, an outer epidermis and an inner dermis. The thickness of these two layers depends on which part of the body they are covering.

Epidermis:

- **Cornified layer:** consists of dead cells. It's the outermost layer.
- **Granular layer:** The cells produced by the Malpighian layer move through the granular layer and then die, so forming the cornified layer.
- **Malpighian layer:** The innermost layer of cells in the epidermis. These cells contain the pigment which gives the skin its colour and helps to absorb U.V. light from the sun. These cells keep on dividing.

Dermis:

Is a layer of connective tissue containing capillaries, sensory nerve endings, lymphatics, sweat glands and hair follicles.

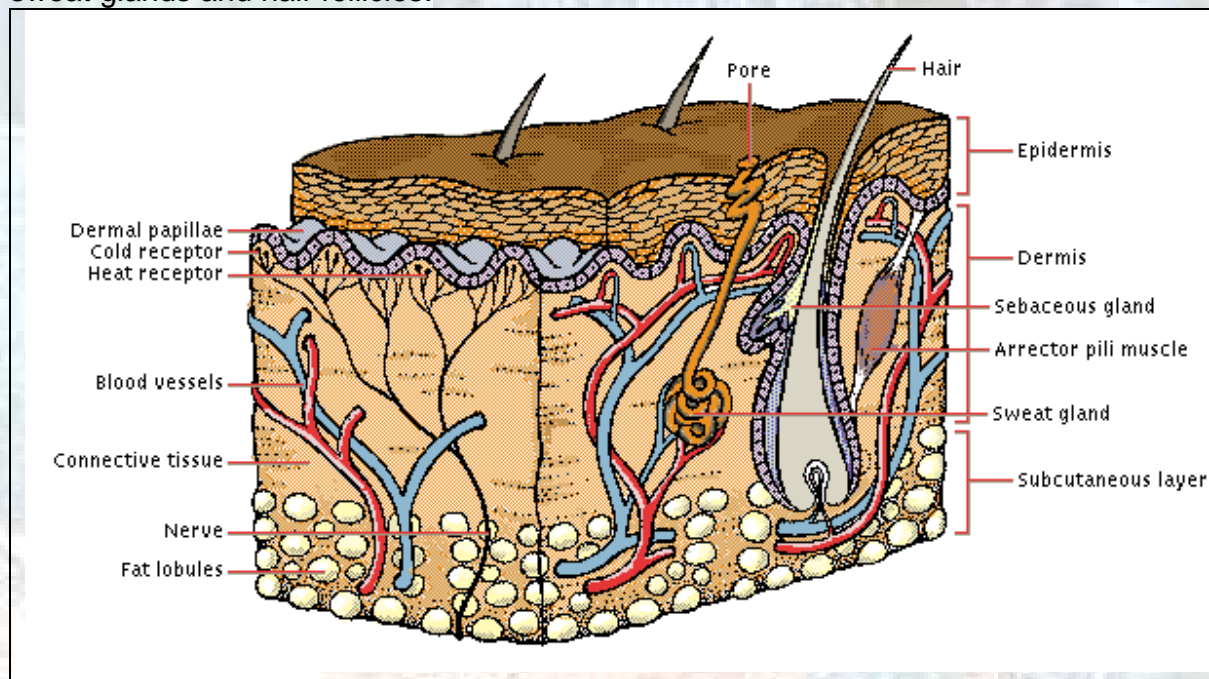

Fig.13.2

C. Negative feedback control.

See chapter Co-ordination and Responses: Subtitle Hormones.

14. CO-ORDINATION AND RESPONSES

When walking, the legs move alternately. During exercise, the breathing rate is increased and the heart beats faster, so more oxygen can go to the muscles. Many bodily functions come into action at just the right moment without unnecessary movements being made.

The linking together in time and space of these and other body activities = CO-ORDINATION.

A. RECEPTORS.

Are sense cells or organs that detect stimuli (= changes in the animal's external or internal environment) and convert it into nerve impulses.

- photo-receptors: transduce light - Energy using pigments.
- thermo-receptors: detect heat.
- chemo-receptors: detect smell, taste.

A.1. The eye.

What you can see when looking at a person's eye are:

- **Pupil:** a hole in the iris which admits light.
- **Iris:** controls amount of light entering the eye.
- **Sclera:** tough, white outer layer of eyeball.
- **Upper & lower eyelids:** moveable curtain pulling tear fluid across the eye when blinking. They also protect against physical damage and bright light.
- **Tear ducts:** drain away tear fluid.
- **Lachrymal glands:** under upper eyelid. Produce tear fluid containing salt and Na-bicarbonate to lubricate the eye surface and to wash away debris. It contains enzymes to destroy bacteria.

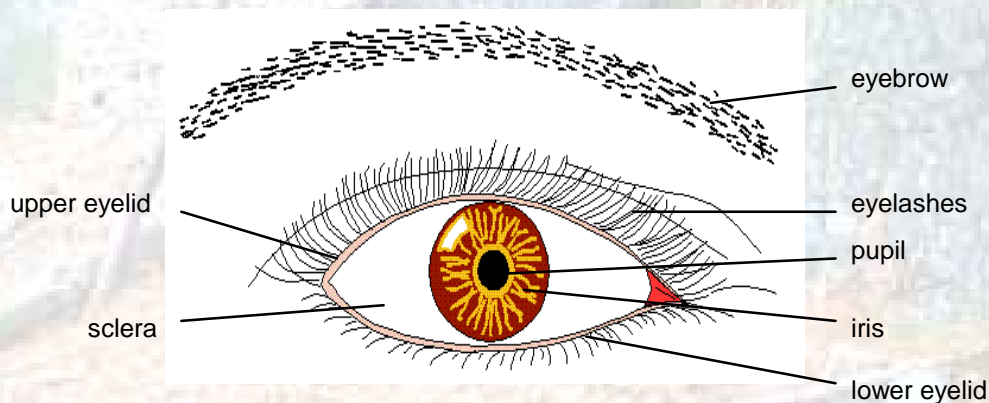

Fig. 14.1

Horizontal section.

- **Conjunctiva:** thin transparent layer to protect the cornea.
- **Cornea:** transparent front portion of sclera.
- **Sclera:** outer fibrous coat; a white opaque layer.
- **Iris:** pigmented front portion of choroid. It controls light entry.
- **Pupil:** admits light.
- **Lens:** refracts light rays; is covered with an elastic membrane; its shape alters to adjust focus.
- **Ciliary body:** thickened edge of choroid; it contains ciliary muscles. It secretes the aqueous humour.
- **Ciliary muscles:** initiate changes in lens shape.
- **Suspensory ligament:** holds lens in position.
- **Retina:** contains light receptor cells (rods and cones)
- **Fovea:** composed mainly of cones, the point of most accurate vision
- **Blind spot:** exit of nerve fibres from the eye. No rods and cones here.
- **Optic nerve:** conveys impulses to the brain.
- **Choroid:** thin, black layer to reduce reflection of light in the eye. It contains a network of blood vessels for oxygen and food supply for the eye.
- **Aqueous humour:** plasma-like fluid housing the iris and lens. It maintains the shape of the front part of the eye. It refracts light rays.
- **Vitreous humour:** plasma-like fluid containing protein, albumin, therefore it is jelly-like. It maintains the shape of the eyeball.

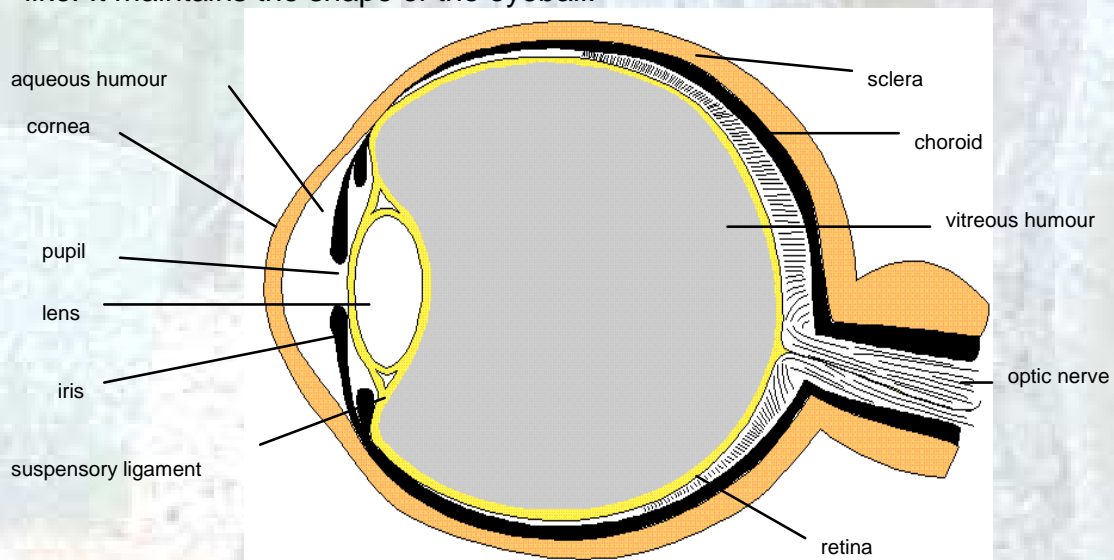

Fig. 14.2

The retina is the layer inside the eye on which an image will be formed. It contains cells sensitive to light. According to their shape, they are called cones and rods. Only cones are sensitive to coloured light but the rods are more responsive to light of low intensity.

Created by Bernard Brochez

A.2. Image formation and vision.

Light from an object enters the eye and gets refracted by the cornea, the lens and the humours and becomes focused so that "points" of light from the object produce points of light on the retina.

The image in the eye, on the retina is REAL, UPSIDE-DOWN and SMALLER than the object.

The cones and rods get stimulated by the light and send impulses in the nerve fibres. The impulses pass in the optic nerve to the brain where an impression is made of size, distance, nature and colour of the object.

The inverted image on the retina is corrected in the optical centre of the brain to give an upright impression.

How do we see all objects, no matter where they are (near, far) evenly sharp?? This happens, because our eyes can adjust their focal length of the lenses. This process is known as:

ACCOMMODATION.

Near-by object:

The ciliary muscles running round the ciliary body contract. The ciliary body holds the suspensory ligament which pulls on the lens. Since the ciliary muscles contract, the tension in the suspensory ligament is reduced and the lens shrinks and becomes thicker. A thicker lens has a shorter focal length so the object is seen sharp.

Distant object:

The eye is at rest, the lens has a long focal length and distant objects are seen.

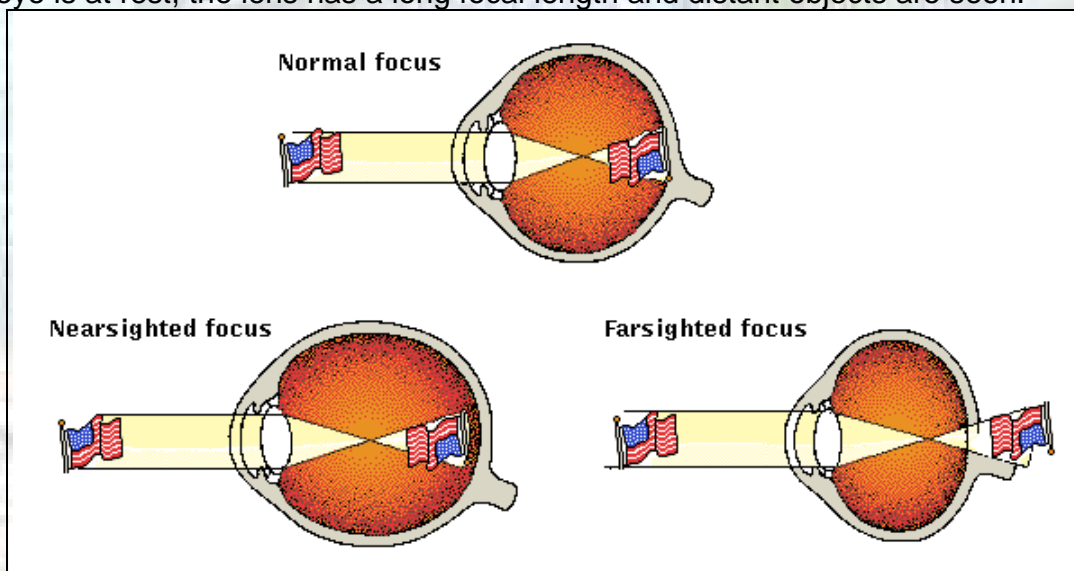

Fig. 14.3

Created by Bernard Brochez

Long sighted persons suffer from small eyeballs or "weak" lenses. Light from a distant object is brought to a focus on the retina, but from a close object, its focus is behind the retina.

Glasses will have converging lenses.

Short sighted persons suffer from large eyeballs. Light from a distant object is focused in front of the retina.

Glasses will have diverging lenses.

A.3. Pupil reflex in different light conditions.

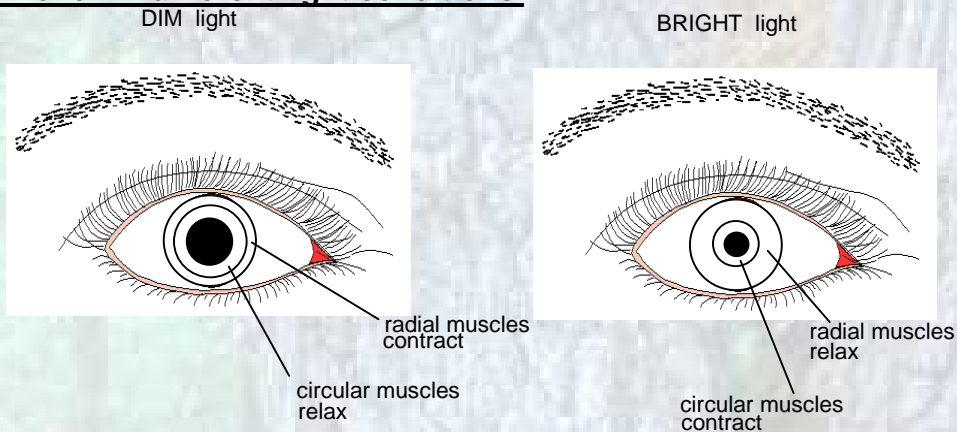

Fig. 14.4

B. THE BRAIN.

The C.N.S. (Central Nervous System). grows from a hollow tube during early embryonic development. As the embryo develops, the front part of the tube enlarges in a series of uneven bulges, until it's possible to pick out 3 main parts: FOREBRAIN, MIDBRAIN, and HINDBRAIN + the long straight SPINAL CORD.

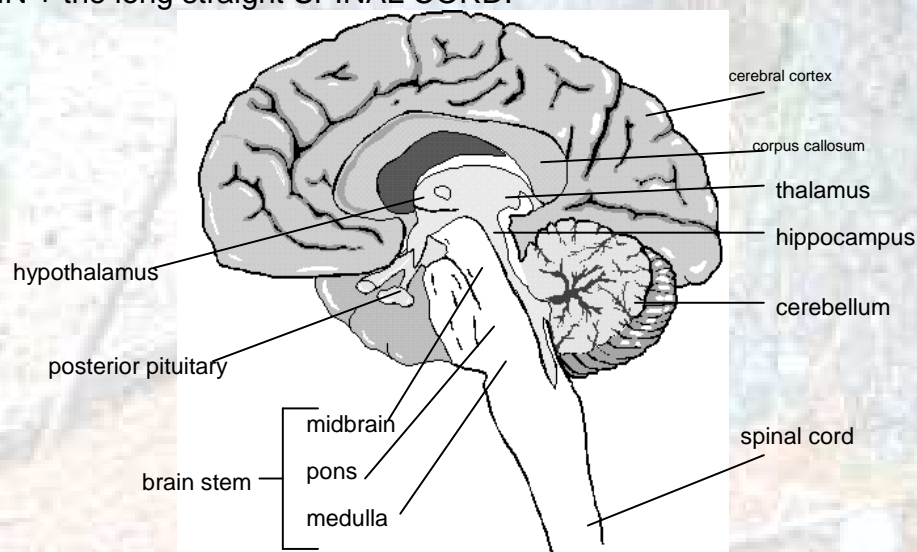

Fig. 14.5

Created by Bernard Brochez

B-1. HINDBRAIN.

- The most obvious part is the **MEDULLA**, the enlargement of the spinal cord as it enters the brain. Through it pass many of the sensory and almost all of the motor neurones on their way to or from higher centres (= centres which integrate a broad range of information).

It controls such automatic, or REFLEX, functions as breathing, swallowing, vomiting and constriction of blood vessels.

- The **CEREBELLUM** is an outgrowth of the medulla and during evolution it has acquired much of the central control of equilibrium (balance) and movement.

B-2. MIDBRAIN.

- In mammals it controls reflexes of the iris of the eye and the eyelids, and it analyses and relays information coming in from the ear via the auditory nerve.

B-3. FOREBRAIN.

Has 2 major parts:

The **Diencephalon** contains thalamus, hypothalamus and the posterior lobe of the pituitary gland.

The **Telencephalon** = anterior part of the forebrain.

The **Hypothalamus** is a vitally important area where the nervous and hormonal systems interact.

The **CEREBRUM** is divided by a fissure into the R. and L. **cerebral hemispheres**.

The deeper layers (**hippocampus**) of the hemispheres are important in regulating emotional state and probably short-term memory. Above these areas, the cerebral cortex lies like a cap of a wrinkled mushroom over the rest of the brain.

The cerebrum consists of grey matter (no white, fatty myelin sheath) and white matter (myelin).

E.g. corpus callosum: the largest myelinated tract connects the bases of the cerebral hemispheres, so the right half of the brain knows what the left half is doing.

The 2 cerebral hemispheres can operate as 2 different brains. Each half of the brain controls structures on the opposite side of the body; the nerve tracts cross over at the lower nervous centres.

The left side of the brain is usually dominant, and it seems to be this side that controls speech, writing, logical thought and mathematical ability.

Lateral view of the cerebral cortex showing functions assigned to different areas.

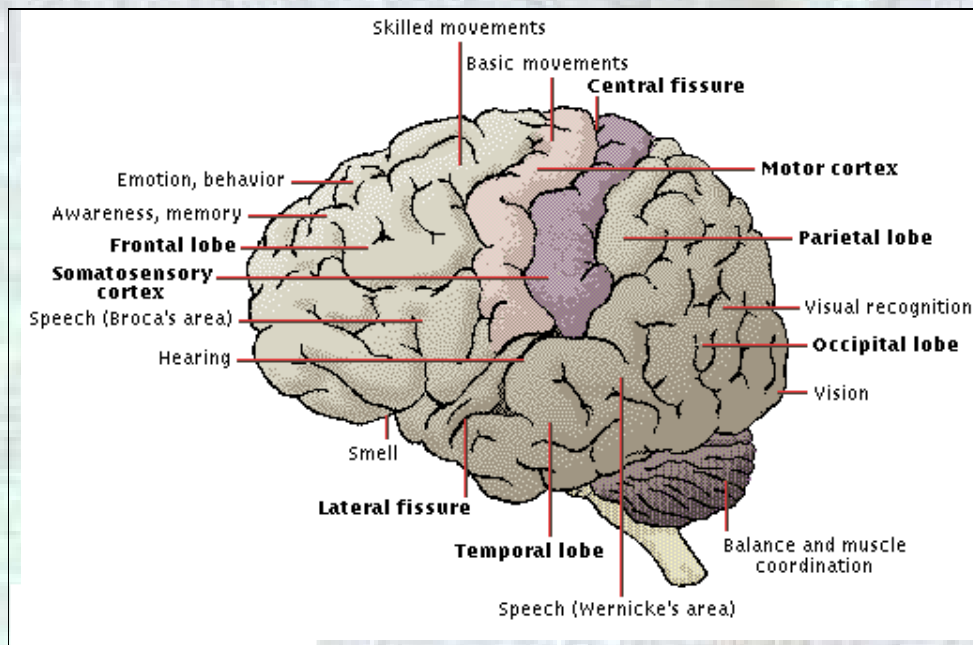

Fig. 14.6

B-4. SPINAL CORD.

Is a rope of nervous tissue that extends from the base of the hindbrain to the end of the vertebral column. Like the brain, it contains a central fluid filled cavity. The grey matter again consists of cell bodies; the surrounding white matter are bundles of myelinated axons carrying information to and from the brain and other parts of the spinal cord.

The spinal cord is a relay system carrying information between brain and the peripheral N.S. It is also the seat of the many spinal reflexes that allow the body to make quick responses.

C. NERVE CELLS (NEURONES)

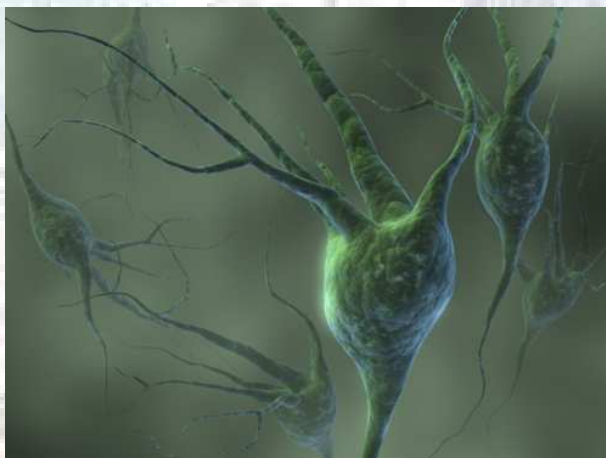

Make up the Nervous system. They are small masses of cytoplasm with a central nucleus. One or more branching, cytoplasmic filaments called **dendrites** conduct impulses **towards** the cell body, while a single long fibre called **axon** conducts impulses **away** from the cell body.

Fig. 14.7

[In a sensory neurone, the single elongated dendrite is called a dendron].
Dendrons and axons are nerve fibres,

Created by Bernard Brochez

they consist of fluid filled cytoplasmatic tubes. Sometimes they are surrounded by an insulating sheath of myelin (to make them transmit impulses faster).

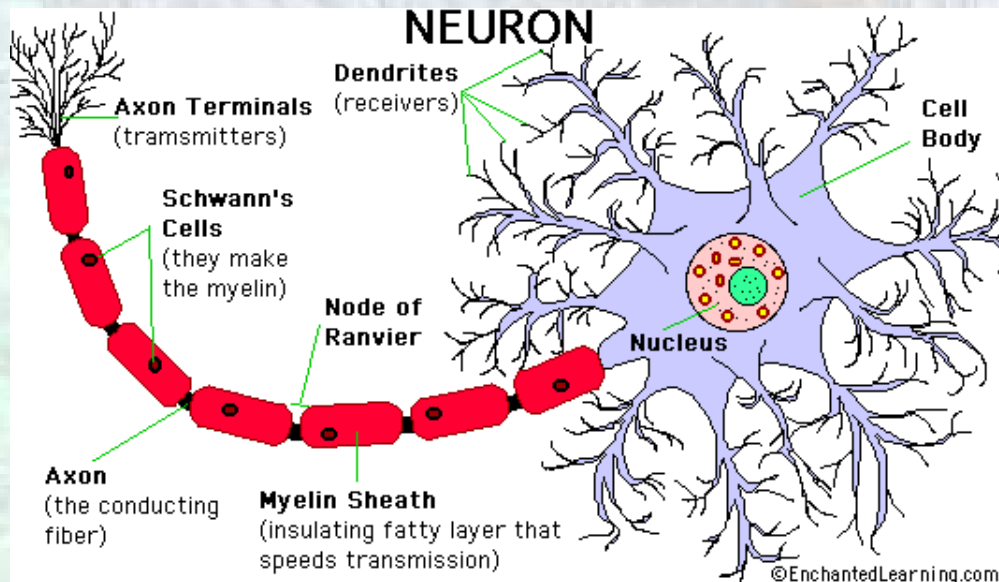

Fig. 14.8

Nerve fibres transmit electrical impulses very rapidly down their entire length and pass them on to the next nerve cell in line. The axon builds up within itself an electrical charge which is released when the nerve is stimulated (the charge has to be built up again before the next impulse can pass).

SENSORY NEURONES: carry information from receptors to the C.N.S. (brain and/or spinal cord).

MOTOR NEURONES: relay information to the body's effectors, the organs that carry out a response (most common effectors are glands, muscles)

INTERNEURONES: relay messages from one neurone to another.

Neurones pass information to one another across small spaces, or synapses, that separate 2 neurones. Each neurone may synapse with many others, and so a single neurone may receive information from, or send information to, many other parts of the body.

C-1 Reflex action.

This is a rapid, automatic response to a stimulus, controlled by a reflex arc, which consists of a sensory neurone, usually 1 or more interneurones, and 1 or more motor neurones.

(E.g. contraction of iris, blinking the eye, sneezing). We are aware of the action but we can't control it !!

Touching a hot plate.

Heat receptors in the skin are stimulated ----> they fire off impulses along the sensory neurones in a nerve of the arm. The impulses enter the spinal cord via the DORSAL ROOT. In the grey matter of the spinal cord, the impulses pass on to an interneurone across a synapse. Then another synapse sends the impulse to one or more motorneurones. These motorneurones leave the spinal cord via the VENTRAL ROOT and the impulse causes the muscles to contract. As a consequence, you will remove your hand from the hot object.

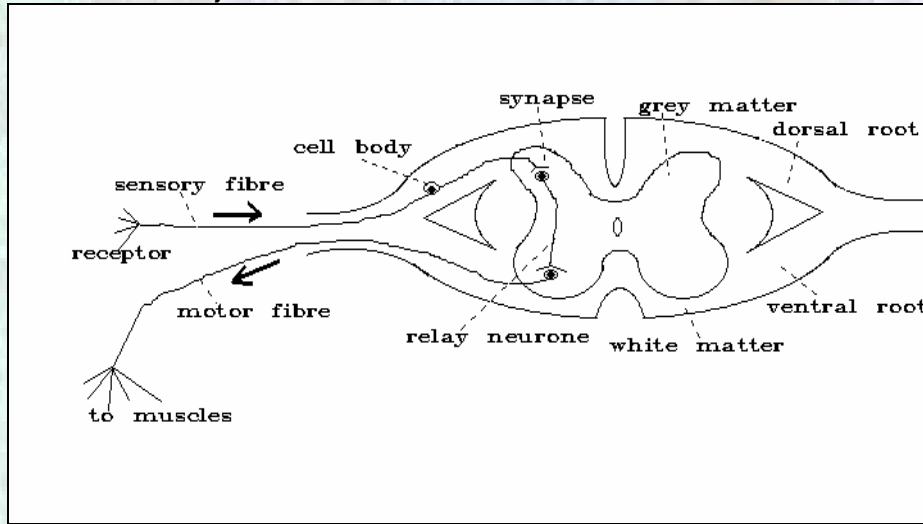

Fig.14.9

In a reflex action, there is little control from higher centres. This is to save time. The long trip with information to the brain and back to the arm is not made.

C-2 Conditioned reflex.

In most reflexes, the stimulus and response are related. E.g. chemical stimulus of food through smell ---> salivation will start.

It is possible for a different or irrelevant stimulus to produce the same response.

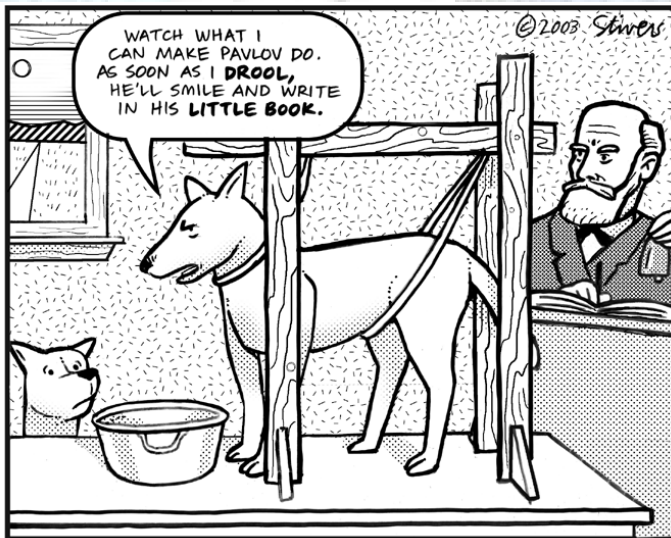

A Russian biologist Pavlov trained dogs for some weeks. He rang a bell when the dogs were fed. After some weeks, the dogs started salivating just with the sound of the bell. No food was present.

Many of our own actions (walking, riding a bicycle) are complicated sets of conditioned reflexes (by concentrating and practice).

Fig. 14.10

Created by Bernard Brochez

C-3 Plasticity in the nervous system.

Is the ability to learn. If a frog's eyes are surgically rotated 180° in their sockets, the frog thinks that the prey is in direction exactly opposite from where the prey really is. It will jump in the opposite (= wrong) direction.

A mammal which has more plasticity can compensate for such a shift in its visual world. You have made such a change in learning to comb your hair while looking in a mirror.

D. HORMONES

Are substances that are produced in one part of the body and specifically influence certain activities of cells in another part of the body.

Originally, hormones were defined as chemical messengers (e.g. testosterone and insulin), produced by ductless endocrine glands (like testis & pancreas), that travel through the blood and exert their effects some distance from where they were produced.

(Testosterone is produced in testis, but it causes an increase in the size of the muscles, among other effects).

We now know, however, that animals have dozens of chemical messengers in addition to those produced by endocrine glands.

We have:

- Hormones produced by endocrine glands.
- Hormones and transmitters produced by neurons (oxytocin: induces labour during childbirth)
- Local chemical messengers (histamine: immune response)
- Pheromones (e.g. in insects).

D-1. Hormones produced by endocrine glands.

The glands have no ducts or openings. The hormones enter the blood as it passes through the glands. They are circulated all over the body and when the hormone reaches its target (organ), it causes certain changes to take place.

Generally speaking, the actions of hormones are slower and more general than nerve action and they control rather long-term changes (rate of growth, sexual maturity...)

When the hormones pass through the liver, they are converted to relative inactive compounds which are excreted by the kidneys.

Created by Bernard Brochez

Thyroid gland

Found in the neck, in front of the windpipe. It produces thyroxin which stimulates growth and metabolism and metamorphosis in amphibians.

Reproductive organs.

Ovaries: Produce oestrogens (estradiol, estrone). They initiate and maintain sexual maturity in female mammals (affects uterus, vagina, mammary glands, skeleton, sexual behaviour, metabolism.....)

Testes: Produce testosterone which initiates and maintains sexual maturity in male mammals; necessary for sperm production. (affects voice, musculature, skeleton, sexual behaviour....)

Pancreas.

Produces insulin which takes care of a decrease in blood sugar. It determines how much glucose is converted into glycogen.

DIABETES MELLITUS: the person's insulin is not working properly. As a result, he will suffer from increased blood glucose levels. As diabetes progresses, this lack of sufficient insulin disturbs the metabolism of fats and proteins. The urine of the person will also contain glucose.

Signs:

- may drink large quantities of water.
- urinate frequently.
- may be hungry all the time.
- lose weight and strength.
- have dry skin.
- have pains in the legs.
- may have slow healing infections.

Treatment:

- administration of insulin. In former days, they used insulin isolated from pigs. Nowadays, biotechnology has provided people with human insulin, made by bacteria which were engineered.
- Taking care of diet and hygiene.

Pituitary gland.

Also called the Master Gland, since many of the pituitary hormones act upon and regulate the activity of other endocrine glands.

Created by Bernard Brochez

A.D.H. (Vasopressin) [Anti-Diuretic Hormone = opposing the tendency to excrete water.] Takes care of water resorption by nephron tubules.

Oxytocin (= neuro-hormone). Takes care of uterine contractions in mammals + milk production.

F.S.H. [Follicle Stimulating Hormone]. Production of gametes in both sexes.

L.H. [Luteinizing Hormone]. Secretion of sex hormones by gonads in both sexes + ovulation in females.

Prolactin. For mammary gland growth and lactation in mammals.

Adrenal glands: situated above the kidneys.

Cortex of adrenal gland makes cortisone which stimulates the metabolism of carbohydrate, proteins, fats.

The adrenal medulla (inner zone) produces adrenaline (Epinephrine). This hormone is excreted in stress situations. It causes the blood vessels in skin, and abdominal organs to constrict, decreasing blood supply to these organs.

It also causes local vasodilatation, or widening of the arterioles and capillaries in the muscles and heart, increasing the blood supply to these organs.

Adrenaline increases the breathing rate and the heart beat rate. It also increases the blood sugar (More E for muscles)

It is excreted in times of fear, anger, stress, shock...

Hormones carry out 2 basic kinds of regulation:

- They may contribute to the body's physiological homeostasis: a change in certain conditions within the body causes the release of hormones that reverse the change (e.g. negative feedback)
- Hormones play a role in adaptive reactions to events outside the body. E.g. Hormones ensure that an animal will be in reproductive condition when environmental conditions favour the survival of the young.

NEGATIVE FEEDBACK.

Mechanism whereby the change detected in some condition stimulates compensating physiological activity that brings the condition back within its normal range.

E.g. Thermostat: a drop in temperature makes the thermostat to turn the furnace on. When the set temperature is reached, the thermostat turns the furnace off.

BIOLOGICAL E.G.

1. A drop in the level of Ca in the blood causes secretion of parathyroid hormone by the parathyroid glands. This hormone stimulates the release of Ca from the bones, decreases the excretion of Ca by the kidneys and increases the absorption of Ca from the intestines.

Within a few hours, the level of Ca is back to normal.

The rise in Ca level, in turn, tends to decrease the secretion of parathyroid hormone.

This negative feedback loop is one of the control systems ensuring that the level of Ca in the blood remains constant.

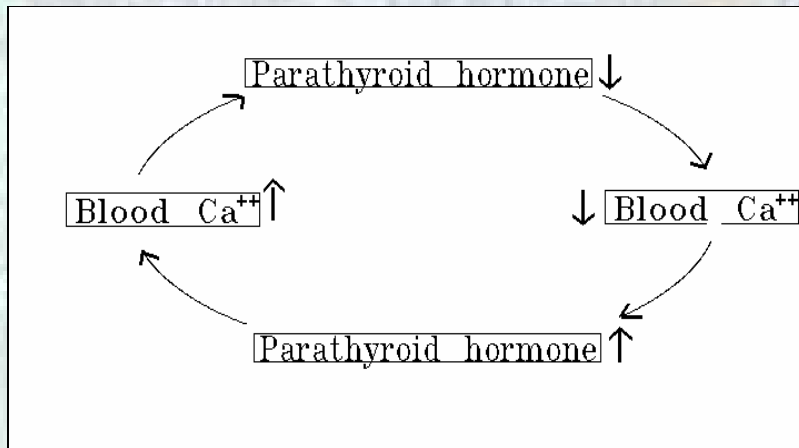

Fig .14.11

2. A male vertebrate must have the right levels of both testosterone and L.H. in the blood for the testes to produce sperm and function properly. L.H. stimulates testosterone secretion, but testosterone inhibits the secretion of L.H.

So if the conc. of testosterone in the blood rises, it inhibits the secretion of L.H., and less testosterone is produced until the level of testosterone falls low enough that the inhibition of L.H. is turned off. L.H. secretion then rises again stimulating the secretion of more testosterone.

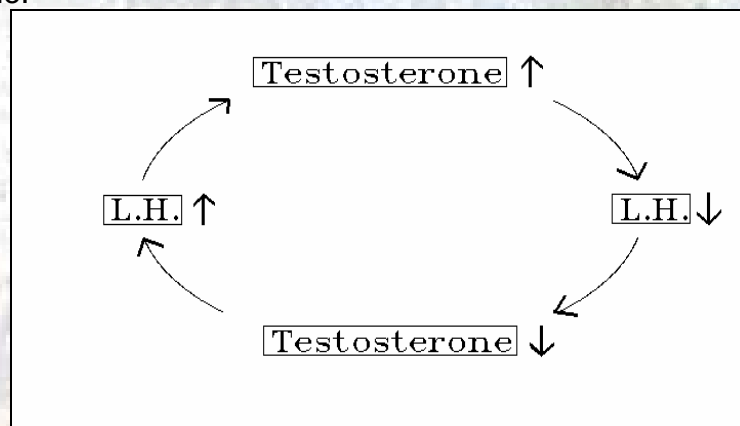

Fig. 14.12

Chemical control of plant growth.

Zinc is a micro-nutrient for plants, and it is needed in the production of the plant hormone AUXIN, which causes elongation or enlargement of cells during growth.

Auxin plays a role in phototropism: the directional growth of a plant in response to light. If a plant receives light from one side only (e.g. at a window), the stem's zone of elongation will curve and the shoot grows towards the light. If the light is all around, the plant will grow straight upward.

Study on oat seedlings:

The coleoptile (a sheath) covers the first leaves of the oat seedling, and other grasses and cereals. As long as the coleoptile is in darkness, it grows upwards (= negative geotropism). If it is exposed to light from one side, it shows positive phototropism and bends towards the light.

Charles Darwin studied this phototropic response by covering different parts of oat coleoptiles and subjecting them to light from one direction.

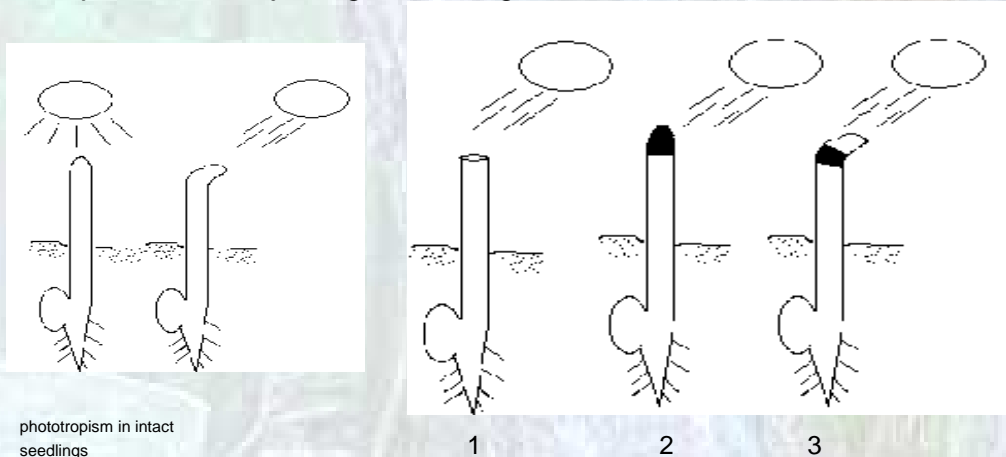

phototropism in intact seedlings

Fig. 14.13

1. Tip was removed -----> no more growth
2. Tip covered -----> further growth (straight up)

3. Tip exposed, zone of elongation covered -----> growth + phototropism

How can a coleoptile tip exert this control???

Animal study showed that response to the environment was due to:

- nerve impulses.
- hormone production.

In 1926 Fritz Went performed his experiments:

A: Agar block inserted between coleoptile tip and region of elongation.

B: Agar block allows auxin to pass through; phototropic response still occurs.

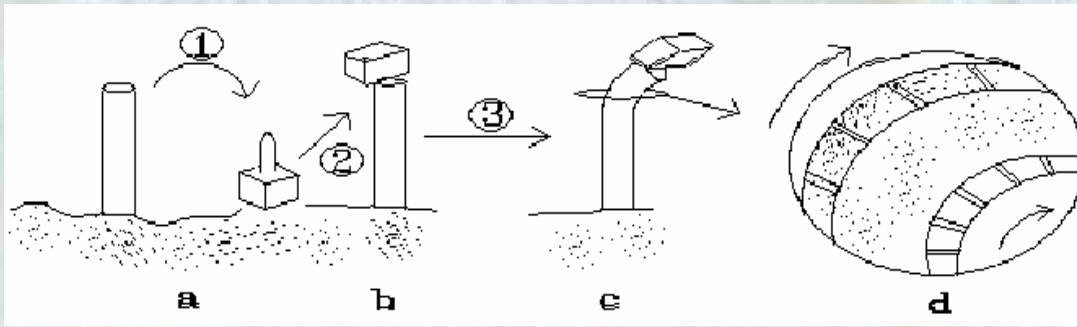

Fig. 14.14

- An agar block is placed under a severed tip.
- The tip is removed and the block is put on one side of a second coleoptile.
- the coleoptile bends away from the side of auxin application.
- The greater concentration of auxin on the left stimulates more elongation. Coleoptile bends towards the right.

Herbicides (weed killers)

Auxins are synthesised from the amino acid *tryptophan*

Fig. 14.15

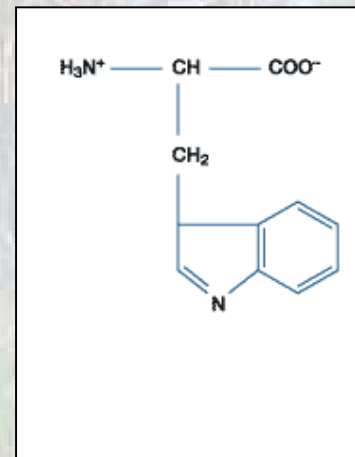

Synthetic auxins (e.g. 2, 4 - D = 2, 4 - Dichlorophenoxyacetic acid) are used as weed killers in lawns.

Dicots are more sensitive to low concentrations of auxins than are monocots. Since most "weeds" in lawns are dicots, and grasses are monocots, the application of a certain dosage of synthesised auxins causes the dicots literally to grow themselves to death. They grow abnormally, becoming grossly deformed before they finally die. Monocots are not visibly affected.

In the Vietnam War, airplanes were spraying "agent orange", a herbicide containing synthetic auxins on forests and crops. The forest trees lost their leaves, so the enemy was seen.

A contaminant in the spray (a dioxin) was found to cause malformations of developing foetuses. The substance was then found in the drinking water and fish (major source of protein in the Vietnamese diet), and the spraying was abandoned.

Scientists later found a way to reduce the amount of dioxin in the spray, but recent research showed that amounts of dioxin were found in beef fat and human milk. The herbicide is now banned.

Dioxin is a powerful carcinogen (= agent causing cancer).

Created by Bernard Brochez

Auxins are also used to counteract the effects of hormones that promote the dropping of fruit from trees. Spraying auxins on apple and pear trees makes the trees retain and ripen more of their fruits.

The major plant hormones are:

- Auxins
- Gibberellins
- Cytokinins (cell division + growth)
- Abscisic acid
- Ethylene

15. TROPISMS AND TACTIC RESPONSES

A. Tropisms.

Definition: The involuntary movement of an organism activated by an external stimulus wherein the organism is either attracted to or repelled from the outside stimulating influence. An example is heliotropism, the movement wherein plants turn toward the sun.

A plant must respond to stimuli in its physical environment. Growth responses to environmental gradients are known as **tropisms**.

Geotropism: the response of a plant to gravity. In most plants, the roots are **positively geotropic**, tending to grow downwards, while the shoot is **negatively geotropic**, growing away from the centre of the earth, or up.

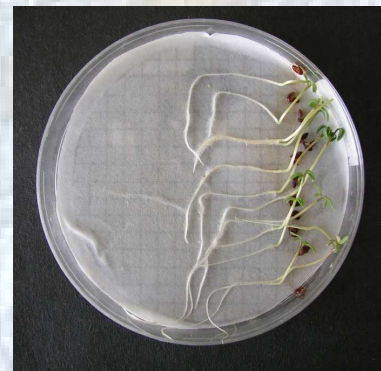

shoot
centre

Fig. 15.1

Phototropism: directional growth of a plant in response to light.



Fig. 15.2

Hydrotropism: directional growth of roots in response to water.

Geotropism and phototropism are due to differential growth which is regulated by auxins.

(You can read more about auxins in the chapter Co-ordination and responses.)

B. Tactic responses.

Invertebrates show very simple behaviour because they are simple organisms; they don't show as complex behaviour patterns, as mammals do. Mammals have emotions, show love, affection.....

Animals have simpler behaviour compared to humans. A zebra for instance only cares for her food and drink, her young one, her partner that she needs to mate....

Invertebrates are only concerned about their environment and some other things (partner during reproduction time) and will therefore move to an environment which suits them best. Earthworms will crawl to moist places. They have a definite preference to moisture. If they have the choice over light and dark, their preference is not so pronounced.

The responses of a species of small invertebrate animal, in two choice chambers, were investigated. Twenty animals were put in the middle of each dish, and their distribution observed after ten minutes. The exp. was repeated many times, and the average number in each chamber is noted as shown below.

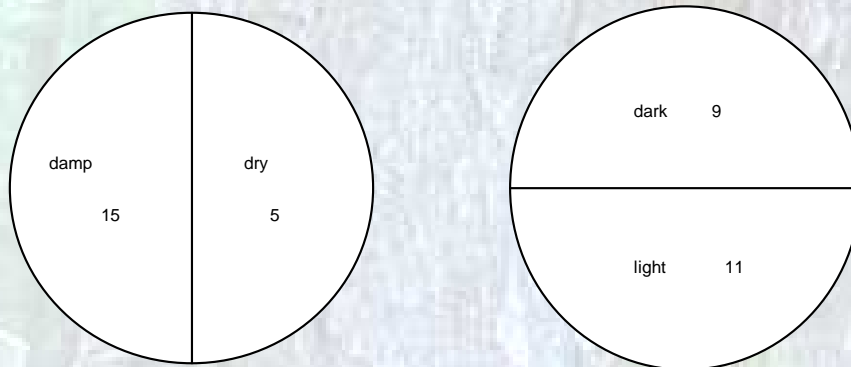

Fig. 15.3

If the animals were given the choice over 4 chambers, their distribution was as in the figure below. This is exactly as we would have expected it to be, knowing that they don't really care for dark or light. Their preference goes out to moist.

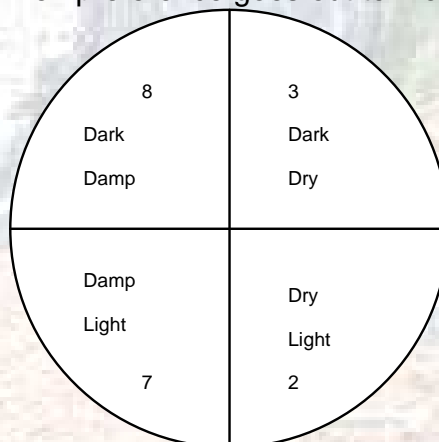

Fig. 15.4

16. USE AND ABUSE OF DRUGS.

Drugs are used to:

- relieve pain and discomfort
- cure or reduce the effects of disease
- promote physical well-being
- modify mood and behaviour.

Among the many substances commonly used are:

1. **ANALGESICS** (drugs that reduce pain. These drugs include aspirin, ibuprofen)
2. **ANTIBIOTICS** (Medicines created using microbes or fungi that are weakened and taken into the body to destroy harmful bacteria)
3. and **TRANQUILLISERS** (A sedative is a drug that depresses the central nervous system (CNS), which causes calmness, relaxation, reduction of anxiety, sleepiness, slowed breathing,...)

Used intelligently, the beneficial effects of many drugs can be realised with a minimal hazard to the individual or to society.

A drug is a chemical structure (substance) externally administered which modifies or affects chemical reactions in the body.

Most drugs are (were) used in medicine, since there is a need for substances to cure several diseases caused by viruses, bacteria, fungi....

E.g. *Penicillin*: = antibiotic (a substance that destroys or stops the growth of bacteria). Made by the ascomycete *Penicillium notatum*. The fungus makes it to reduce competition from bacteria, since they both compete for the same food sources.



Fig. 16.1

Created by Bernard Brochez

Humans use it for the same reasons. Nowadays penicillin becomes less and less used since many bacterial strains are resistant to it.

Antibiotics are also prescribed when you have a serious viral infection. This is not to cure you, but to prevent you from getting an extra bacterial infection, on top of your viral infection!!!!

e.g. **Aspirin**: = salicylic acid. It is a widely used painkiller. It inhibits inflammation, fever, and pain.



But: an overdose of aspirin may cause a high fever, damaged blood vessels, internal haemorrhages, difficulty in breathing, vomiting and coma.

Fig. 16.3

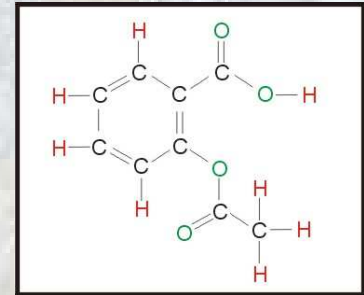

Fig. 16.2

Drugs, narcotics and hallucinogens are among the substances commonly misused in our society.

Drugs + narcotics can be depressants or stimulants.

DEPRESSANTS:

1. Work on the CNS.
2. Reduce functional body activity
3. Produce muscular relaxation

STIMULANTS:

1. Increase activities of the CNS
2. Produce excitement
3. Decrease the desire for sleep.

HALLUCINOGENS:

Are "mind-altering" substances that can produce changes in the state of consciousness of an individual.

ADDICTION refers to the user's:

1. Overpowering desire or need to continue taking the drug and to obtain it by any means.
2. Psychological and physical dependence on the effects of the drug.
3. Tendency to increase the amount of the drug.

HABITUATION refers to the user's:

1. Desire, but not compulsion to continue taking the drug.
2. Psychological dependence (NOT physical).
3. No need or desire to increase the amount.

A. HEROIN

- It is an opium derivate.
- Derived from morphine (= painkiller during W.W.II).
- A white crystalline powder which is bitter in taste.



Fig 16.4

Slang Terms:

China white, black tar junk, skag, horse, dope, H, body bag.

It is usually mixed with milk sugar, quinine, or even washing powder...

1 kg.(= 80 % pure) = several thousands of \$.

Dealers dilute it, adding more milk-sugar, so profits are higher. As a result, criminality arises, since many youngsters don't have the money.

The "cut" heroin that you buy on the streets contains 1 or 2 % heroin.

- It is usually injected intravenous (straight in the vein).
- It is also snorted (sniffed) or skin-popped (injected under the surface of the skin).

Persons using heroin get a pleasurable warm rush and a sense of well being. They feel larger than life itself and worries, frustrations... disappear. (EUPHORIA)

TO GET HOOKED: The amount needed to get the same results rises. You need more for the same excitement.

Heroin has the greatest addiction potential of all opiates!!

Addicts who do not get their shot on time suffer from withdrawal sickness: Vomiting, sweating, stomach cramps, diarrhea, headache...

They lose their job if they become sleepy, cranky and unreliable. They go to toilets or bathrooms to get their shot.

Created by Bernard Brochez

The use of non-sterile needles leads to abscesses; arms are completely pricked. As a result veins close up, also due to the effect of the heroin. So the addict will shoot into the veins of neck, ankles and back of the hands.

HEPATITIS + AIDS (syringes are used by more than one) result from non-sterile injections.



Why do youngsters get involved????

- Like to have pleasure and are thrill-seeking.
- To gain status with their group.
- Many are introduced to drugs by friends.
- Sniffing, skin-popping seem intriguing experiences.

B. ALCOHOL

Types:

- Fermented juices containing natural sugars (wine)
- Fermented malt beverages (beer)
- Distilled liquors (whisky, gin, rum, brandy...)

B-1. Factors influencing blood-alcohol levels.

1. THE GREATER THE BODY WEIGHT OF THE PERSON, THE LOWER WILL BE THE BLOOD-ALCOHOL LEVEL RESULTING FROM A GIVEN AMOUNT OF ALCOHOL.

e.g. 50 KG. Body + 1 ounce alcohol ----> 0.06 % alcohol in blood

100 KG. Body + 1 ounce alcohol ----> 0.03 % alcohol in blood
(Twice as much body fluid to dilute the alcohol.)

2. THE GREATER THE AMOUNT OF ALCOHOL BY VOLUME, THE MORE RAPIDLY THE ALCOHOL IS ABSORBED AND THE HIGHER THE BL.-ALCOHOL. LEVEL.

The highest bl. alc. levels result from distilled liquors.

3. THE GREATER THE AMOUNT OF NON-ALCOHOLIC CHEMICALS IN THE DRINK, THE MORE SLOWLY THE ALCOHOL IS ABSORBED.

Wines and beers contain greater amounts of non-alcoholic chemicals.

4. THE PRESENCE OF FOOD IN THE STOMACH AFFECTS ABSORPTION OF ALCOHOL.

If food is present in the stomach, the bl.-alc. level may be reduced by 50 %

5. THE MORE RAPIDLY THE DRINKS ARE DRUNK, THE HIGHER THE BL. ALC. LEVEL WILL BE.

B-2 . Effects upon the human body.

There is no guarantee of a "safe" level of drinking. There is always damage to groups of human cells.

Alcohol is absorbed from the stomach and small intestines and is passed into the blood stream.

Alcohol is a depressant to the C.N.S.:

- It reduces activities of the brain.
- There is reduction of attention.
- There is a minimum of discretion and control.
- There is distortion of judgment.
- Loss of equilibrium.
- It slows down responses of eyes, hands and feet.
- It interferes with muscular co-ordination.
- It delays reaction time:
 - No drinks: 1/5 of a second.
 - 3.5 glasses of whisky: 34 % slower.

When the conc. of alcohol in the blood reaches 0.30 % to 0.40 %, it acts as an anesthetic and causes unconsciousness. The cardiac and respiratory centres of the brain can get affected.

When the conc. exceeds 0.50 %: DEATH.

- In the heavy drinker, alcohol destroys brain cells by depriving them of O₂ (Millions of cells will be lost), and braincells are irreplaceable!!!!



- Alcohol stops the liver from burning its normal fuel (fat). It will now burn alcohol. The fats will accumulate in the liver, creating a fatty liver. **CHOLESTOSIS** (stoppage of the flow of bile) may develop.

Fig. 16.5

Created by Bernard Brochez

LIVER CIRRHOSIS = a severe scarring of the liver may arise. Eventually the liver stops its work.

This is one of the most disabling and fatal complications of alcoholism.



Fig. 16.6

- Alcohol affects also the heart by progressively weakening the heart muscles.
- After a night of heavy drinking you will have a **HANGOVER**:
 - A severe thirst
 - a headache
 - fatigue.

This is because of dehydration: water from the cells has to go extracellular, to dilute the blood.

B-3. Social effects.

- Motor vehicle deaths (kill other people)
- Violent + antisocial behaviour (murder, assaults, rape)
- Family life is difficult, unhappy marriages, divorce, broken homes, and impoverished families since salary is spent on beer.
- 1/4 of all suicides are linked to alcohol.
- Women start drinking more and more (pregnancy is in danger)

C. SMOKING.

- The risk of developing lung cancer is 7.6 to 14.2 times greater.
- To get chronic bronchitis, emphysema, chances are about 18 times greater.
- Inhaled cigarette smoke consists of 1 to 5 % CO.
- In smoking mothers, the CO decreases the birth weight of the baby.
- Nicotine + CO are important factors in the mechanism that causes coronary heart disease. (For smokers: 70 % more chance of getting it).

C-1. Smoking + its effects.

- Tobacco contains **NICOTINE**, one of the most powerful of all poisons. 60 mg. is enough to kill, if placed directly into the circ. system.

Created by Bernard Brochez

- Nicotine stimulates an increase in the heart beat rate of as many as 20 beats/minute. This increase lasts at least for about 20 minutes after smoking.
- Nicotine causes constriction of blood vessels, so the temp. of fingers and toes drops.
- Blood pressure, stroke volume of the heart increase.

WHY DOES THE SMOKER SURVIVE THE NICOTINE?

- 25% of the nicotine is destroyed at the lighted end.
- 30% is absorbed by the cigarette.
- 30% escapes into the air.
- 15% goes into the mouth.

Tobacco smoke is a complex mixture of gases, particles and liquids. It consists of hundreds of chem. compounds and hundreds more compounds are created when it burns:

e.g. CO, NO₂, Ammonia, benzene, hydrogen sulphide, arsenic and phenols.

C-2 Chronic bronchitis.

Smoking is the most important cause!!

A fluid (mucus) is excreted by glands along the lining of the bronchial tubes. The cells which line the tubes have cilia which are waving back and forth, propelling the mucus upward and outward. Irritating particles are trapped in the mucus and go out the same way. Irritants in the cigarette smoke can destroy the cilia and the ejection of mucus stops.

In **chronic bronchitis**, the linings of these tubes are inflamed and infected. The cilia are paralysed, then destroyed. Excessive mucus is produced. The air flow from and to the lungs is obstructed. Coughing forces up the mucus. If the tubes become blocked, the person will suffer from **shortage of breath**.

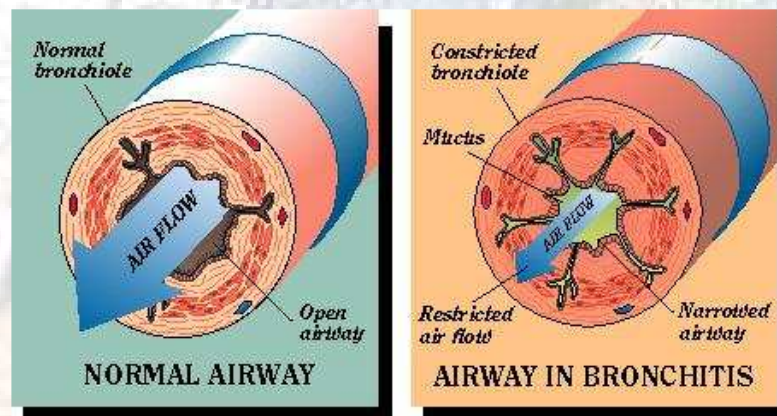

Fig 16.7

Created by Bernard Brochez

C-3. Emphysema.

The air sacs of the lungs (alveoli) are gradually destroyed. The bronchial tubes divide, forming tiny bronchioles which lead into air sacs. These have elastic properties, so they expand or contract as the person breathes.

The air sacs explode, forming bigger sacs. Air can get trapped (balloon out). The elastic properties disappear.

As a result, there will be less contact between blood and oxygen. The oxygen is not exchanged for the carbon-dioxide, so the latter accumulates. The heart has to work harder to pump the oxygen-poor blood to the body tissues.

- With emphysema: 25-30 breaths per minute.
- Without " " : 16 breaths a minute.

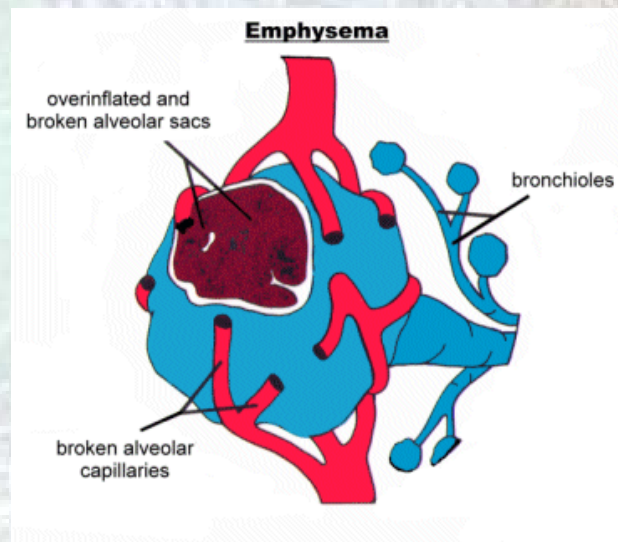

Fig 16.8

C-4. Lung cancer.

Cancer = uncontrollable growth and cell division of one or more cells resulting in a tumour.

Lung cancer is caused when some of the cells forming the tissues of the lungs grow abnormally and form a malignant tumor. The tumor can start in different parts of the lungs. There are two primary types: SMALL CELL or OAT CELL LUNG CANCER. The first spreads rapidly. The second type grows more slowly, and luckily, about 80% of lung cancers are of this type.

Cigarette smoke has various irritating substances in it. Lung cancer starts. Since many human cells have cancer-genes (genes that tell the cells to start dividing uncontrollably) Cigarette smoke induces those genes to become expressed. A cancer develops.

Created by Bernard Brochez

C-5. Coronary heart disease.

CO and nicotine affect the heart and blood vessels. CO reduces the oxygen carrying capacity of the blood. Blood will now have to be circulated more rapidly.

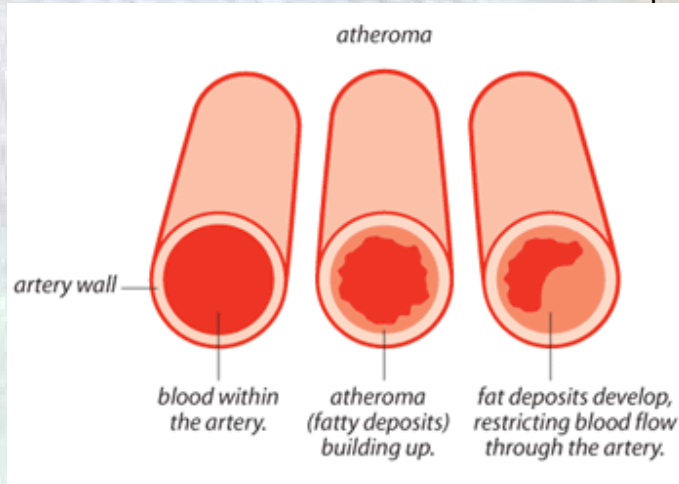

Fig 16.9

The heart pounds an extra 15-25 beats per minute. Blood pressure is elevated 10 - 20 points.

Nicotine increases the heart rate, blood pressure, cardiac output and stroke volume.

C-6. Smoking during pregnancy.

The placenta which nourishes the foetus CAN NOT filter out the nicotine, CO, and cancer producing compounds.

Pregnant women who smoke 2 packs a day block off 40 % of the fetus's oxygen.

The nicotine influences the child's heart rate and blood pressure. It also narrows the placental blood vessels and diminishes the supply of nourishment for the child. The baby will weigh less when born.

Smoking also increases the risk of a premature birth.

Smoking is no longer a "social event". In USA and Europe you are looked at as foolish, stupid and you can risk a penalty if you smoke in public places. Since 1993 there is a tendency to ban smoking!!!



Created by Bernard Brochez

A golden advice (from a smoker) : DON'T EVER START!!!!!!!
Then you will never have to worry about how you are going to quit.

Do not follow the advice of this American advertisement!!!!



Unless you look like me, you could stand to lose a few pounds. Let's face it: slightly chubby but cute in the face is no way to go through life. Smoking can help with that. You smoke now? Good. Don't quit or the weight will just pile on and you'll be helpless to stop it. Helpless. Take care of yourself or you may find someone who does look like me taking care of your man.

VIRGINIA SLIMS

You've come a long way, baby.
Just not as far as me.

**SURGEON GENERAL'S WARNING:
Cigarette Smoke Contains Carbon
Monoxide.**

Fig. 16.10

Commercial billboard for the cigarette brand 'Virginia Slims'.

Pretty stupid...no?

17. DIVERSITY OF ORGANISMS.

A. Bacteria.

Are: very small organisms
Consisting of single cells (1 μm)
Reproducing by cell division
Can form chains of individuals, clumps or films over the surface of static water.

Individuals may be spherical, rod shaped or spiral.
Some have flagella which move the bacterium about; others have pilli with which they attach themselves.

Some need oxygen to respire (aerobic respiration) others are anaerobic (no oxygen is needed to break down compounds)

Some can form spores (a resting stage) with a thick wall. This is used to survive severe conditions (e.g. high temp., drought...)

Bacteria are found everywhere: air, soil, water, food, humans...

Some are pathogenic (causing disease) but most of them are NEEDED in nature: e.g. to break down natural waste products, nitrogen cycle, to produce oxygen in ponds...

Fig. 17.1

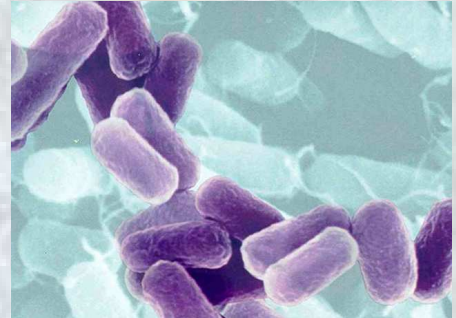

E. Coli bacteria

A-1. Bacteria and food production.

all foods contain bacteria. E.g. milk is sterile when it leaves a healthy cow. By the time it reaches the table, it contains several types of bacteria:

<i>Streptococcus lactis:</i>	}	Ferment the milk sugar (lactose) and produce lactic acid.
<i>Lactobacillus:</i>		

Therefore the pH of the milk goes down, and the milk proteins coagulate.
Pasteurisation retards spoilage by reducing the bacteria population.

S. lactis is however needed to produce many cheeses.
Species of *Lactobacillus* are needed to make yoghurt.

Vinegar is produced by allowing *Acetobacter aceti* to oxidise ethylalcohol in apple cider or wine to acetic acid (vinegar)

Food poisoning comes from toxins produced by bacteria growing in food:

E.g. *Clostridium botulinum*: causes botulism (fig 17.2)

Created by Bernard Brochez

The toxins produced interfere with nerve activity, so paralysis results, and if the breathing muscles are paralysed, it can lead to death.

It grows under strictly anaerobic conditions (= they don't support any oxygen present.) so fresh foods and frozen foods are safe. Canned foods however provide the ideal environment.



Fig 17.2

The toxin can be destroyed by heat, but the endospores must be heated for a long time.

E.g. *Salmonella paratyphi* is found in pork, poultry, eggs.

Main symptoms of the disease are diarrhoea.

A-2. Bacteria and decomposition.

Autotrophs can make their own food from inorganic compounds (CO_2 , mineral ions, and water)

Heterotrophs must absorb organic food molecules produced by other organisms.

Saprobies live on dead organic material, such as dead animals, plants, faeces, dead leaves or bark. They secrete hydrolytic enzymes into the surrounding food source and absorb the resulting small organic molecules and inorganic ions for their own use.

Some convert organic compounds to organic substances (ammonia) which can be absorbed by other bacteria and oxidised further to nitrates.... (See Nitrogen cycle)

Anaerobic bacteria are used in sewage works. They act on the organic solids and release organic compounds from them. Then this mixture is agitated by paddles to

Created by Bernard Brochez

oxygenate it sufficiently for aerobic bacteria to flourish and convert the organic soluble compounds into inorganic salts such as nitrates and phosphates.

B. Fungi.

Eukaryotic, multicellular organisms

Fungi are saprobes or parasitic.

Secrete digestive enzymes which hydrolyse the organic matter.

A fungus disperses itself by spores, usually floating through the air. The spore falls on a suitable food source and germinates. It absorbs food and grows into a thread-like hypha.

The hypha grows rapidly and branches until it resembles a tangled mass of threads.

The body of a fungus, made up of many hyphae, is called a mycelium, which is well suited for absorbing food. A hypha releases chemicals that cause other hyphae to grow away from it. As a result, the fungus spreads out through its food source.

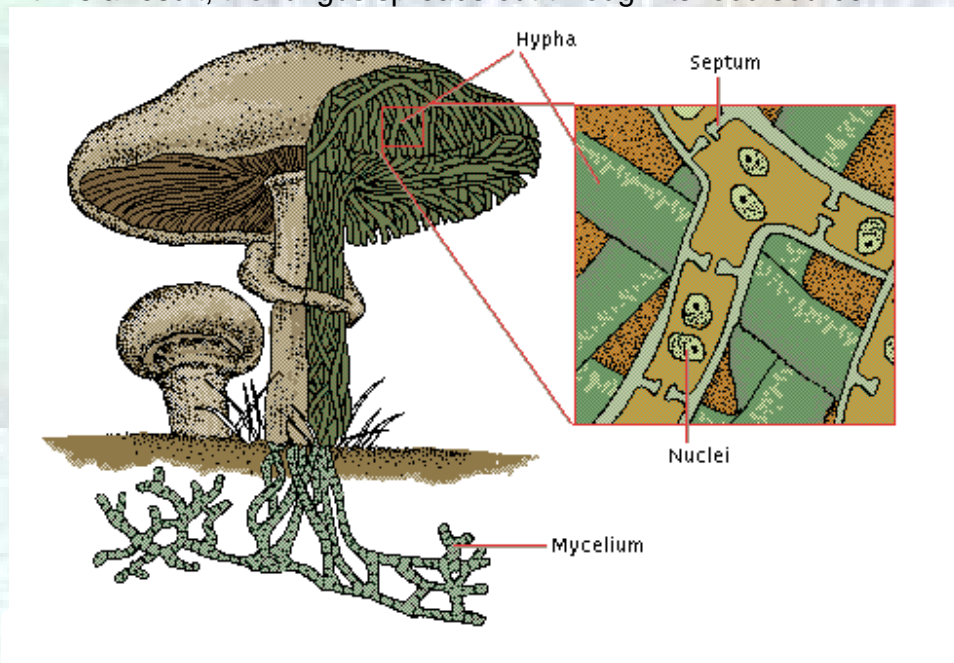

Fig. 17.3

Parasitic fungi absorb nutrients from the body fluids of the host, and parasites of plants may produce specialised hyphae called haustoria, that penetrate a plant's cell wall and lie against the plasma membrane where food can be absorbed.

Some hyphae are COENOCYTIC (= with many nuclei lying in the same cytoplasm). Others are divided by septa (septum) into compartments containing one or more nuclei.

Fungi have rigid cell walls composed of fibrils of either cellulose (plant) or chitin (arthropods).

Created by Bernard Brochez

B-1. Fungi and food production.

Fermented foods keep better than the food from which they are made.

The yeast *Saccharomyces cerevisiae* makes alcohol in the production of wine and beer. (Glucose \rightarrow carbon-dioxide + ethanol + 118 KJ.)

A different strain of this yeast is used in bread making. Here, under aerobic conditions, it doesn't produce alcohol. Instead its respiration gives off Carbon-dioxide which is trapped in the dough as bubbles \rightarrow bread has a light texture.

Several cheeses get their flavours from specific ascomycetes.

Modern soy sauce is produced by hydrolysing soybeans with hydrochloric acid.

The best soy sauce is still made by fermenting boiled soy beans and wheat with the ascomycete *Aspergillus oryzae* for about one year.

Some fungi produce diseases in plants, but are greatly valued in food production.

E.g. *Botrytis* causes spear rot in Asparagus, but is used in wine production.

B-2. Fungi and decomposition.

Fungi are heterotrophic = must obtain their food molecules from outside sources.

They break down organic matter: dead animals and plants, animal wastes, fallen leaves...

Fungi and bacteria are the most important decomposers.

Fungi can grow in relatively high conc. of salts and sugars. (Bacteria would get killed).

Many tolerate extreme acidity (bacteria can't): jams are safe from bacteria but not from fungi.

They can absorb water from the damp air, so they can live in places where there is no liquid water (bacteria can't)

They can survive under anaerobic conditions using fermentation, but they can't grow and reproduce without oxygen.

Bacteria and fungi are the main organisms which keep nature clean.

B-3. NITROGEN CYCLE.

Nitrogen is an essential constituent of many organic compounds especially proteins, nucleic acids...

Molecular nitrogen gas (N_2) making up 78 % of the atmosphere is more abundant than carbon-dioxide.

It is a macro-nutrient for plants along with phosphorus and potassium.

Created by Bernard Brochez

Few kinds of organisms can use molecular nitrogen. Only certain species of bacteria can fix molecular nitrogen by reducing it to ammonia, which is washed away into the soil where it forms ammonium compounds.

NITRIFYING BACTERIA.

Nitrite bacteria: oxidise the ammonium compounds to nitrites (NO_2^-)

Nitrate bacteria: oxidise nitrites to nitrates (NO_3^-) and these can be taken up in solution by plants.

Faeces of animals are rich in nitrogenous waste products → ammonia →
Nitrite → nitrate.

NITROGEN FIXING BACTERIA.

Since green plants can not absorb the nitrogen in the air, some plants have developed some sort of Symbiosis with bacteria which can. These bacteria combine it with other elements making nitrogen compounds. These bacteria can be found in the soil as free living organisms, or they live in root nodules or swellings (e.g. Clover).

DENITRIFYING BACTERIA.

Live in the soil and obtain their energy by breaking down compounds of nitrogen to gaseous nitrogen which escapes into the atmosphere.

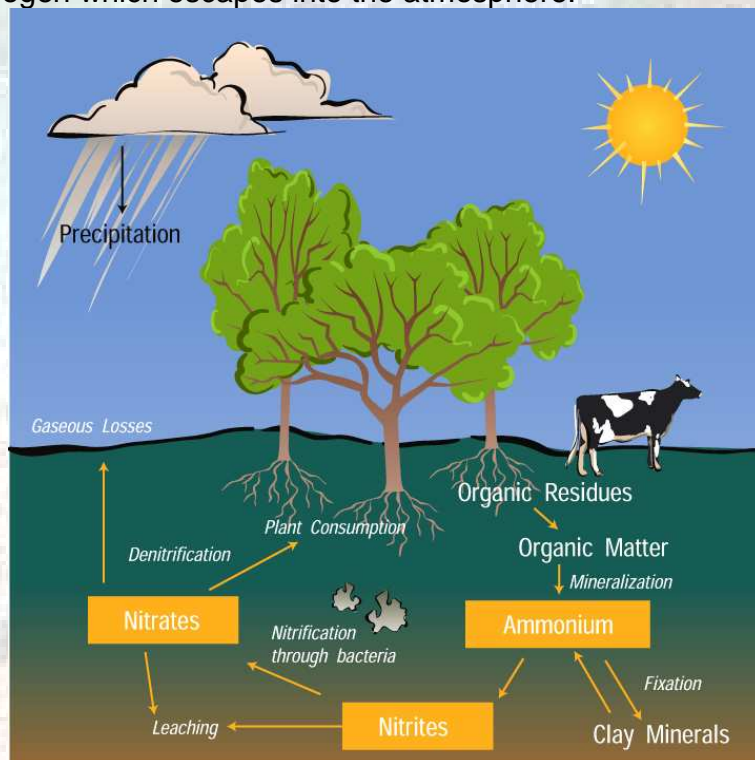

Fig 17.4

Created by Bernard Brochez

C. VIRUSES.

Are very small, ranging from about 15 to a few hundred nm. in diameter.

The "basic" virus particle consists of a nucleic acid molecule (with all the information), surrounded by a protein coat, the CAPSID. Some have in addition an outer envelope of glyco-proteins or lipids covering the capsid. Most of these enveloped viruses infect animals.

Virus particles may also contain one or a few enzymes (needed for them to invade a cell or for replication of the viral nucleic acid).

Most viruses are either helical or polyhedral, or a combination of the two. A more complex structure occurs in the bacteriophages T2, T4, T6 (T-even phages), which infect *E. coli*.

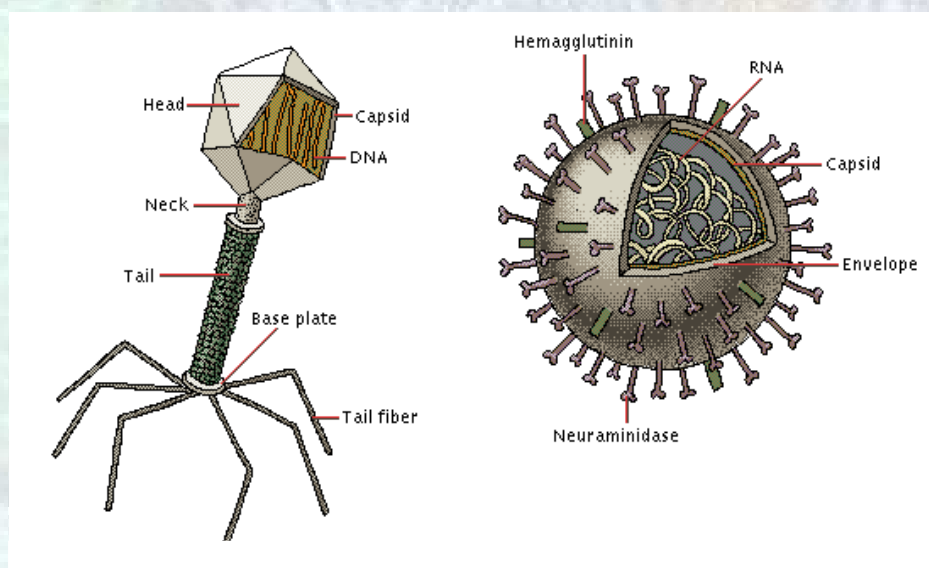

Fig 17.5

C-1. Reproduction

Lytic cycle: A virus invades a cell and injects its DNA. The cell reproduces the virus which get dispersed when the cell breaks or **lyses**

e.g. T-even phage.

Viruses with this life cycle are called VIRULENT (extremely damaging)

Lysogenic cycle: The phage DNA is injected and is joined to that of the host cell. It gets replicated with it over many generations. The cell with such viral DNA is called a lysogenic cell. An external stimulus causes the lysogenic cell's DNA to enter the lytic cycle, releasing intact phages

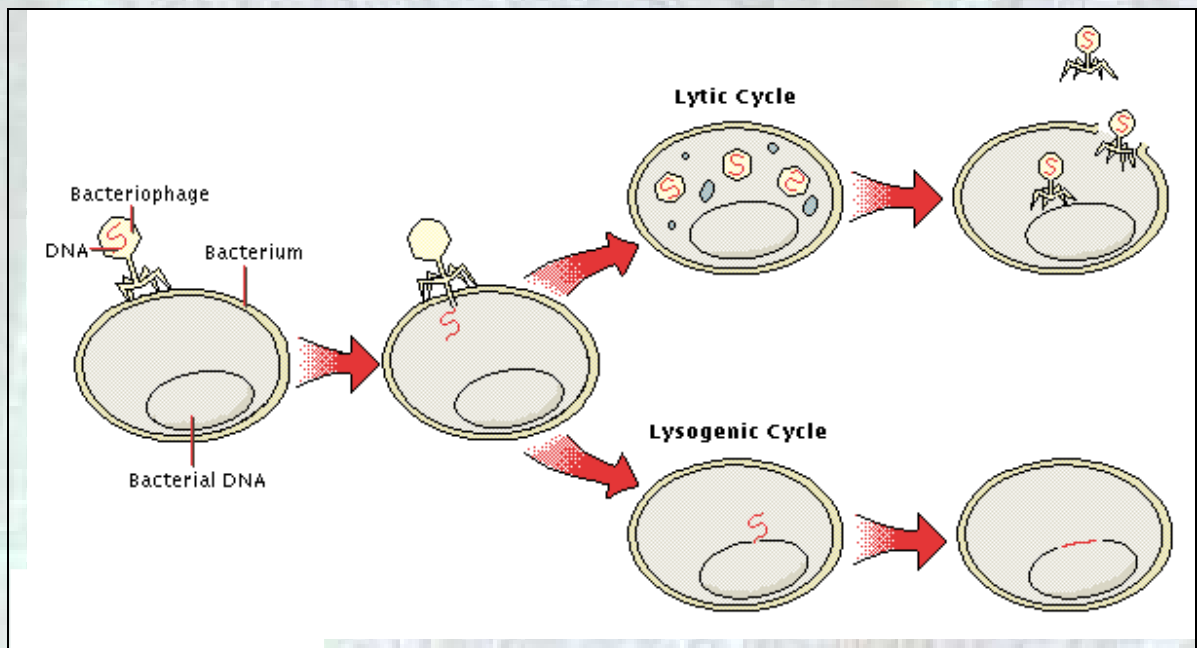

Fig 17.6

Viruses infect plants and animals (humans)

In plants they are spread by the wind or insects. Usually it is impossible to cure viral infections in plants.

E.g. Tobacco mosaic virus, Tobacco necrosis virus.

In animals: Rabies, chickenpox, polio, colds, influenza...

Viruses usually kill their host cells (lysis) except for the ones causing cancer.

e.g. Herpes (STD): signs: a rash or minor itching in the genital region. Then a cluster of blister-like lesions forms, breaks open and ulcerates. The lesions are painful with pain radiating unto the legs.

Cause: Sexual intercourse.

D. INSECTS.

Most abundant group of animals. Many species are still undiscovered.

Have a body in 3 parts: HEAD - THORAX - ABDOMEN.

They have 6 legs and 1 or 2 sets of wings.

Are the most widely spread group of animals: From North to South Pole.

Created by Bernard Brochez

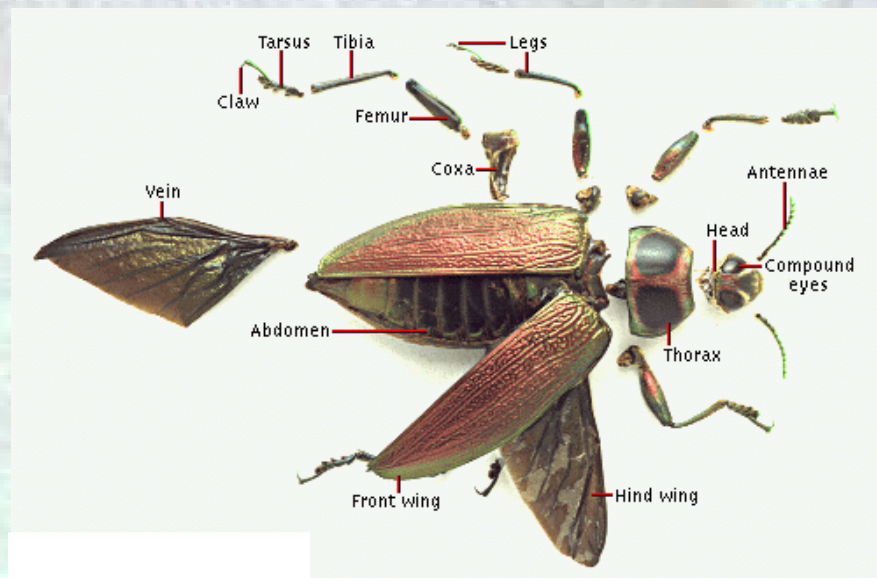

Fig 17.7

D-1. HUMANS AND INSECTS.

Without insects, many flowering plants would never be pollinated. Numerous beetles, ants and fleas are important decomposers.

Insects attack humans directly with stings and bites. Blood sucking insects transmit many diseases: Malaria, river blindness and sleeping disease kill millions of people. Many insects compete with humans for food and crops. Crops in tropical climates suffer more, since insects grow and reproduce faster in the tropics (Locust swarms.)

Insects do a fine job in pollinating trees and flowers. Bees produce honey; the silk moth produces silk.... However: many transfer diseases.

D-2. HOUSEFLY.

The entire body is covered with pathogenic bacteria. Most of the bacteria however are not spread this way. This happens when the fly is eating. A fly cannot eat solid foods, so it has to vomit upon its meals to dissolve them and lick them. Many bacteria enter the food this way.

---> Typhoid fever, diarrhea....

Fig 17.8



D-3. COCKROACHES



Wherever food is stored, cooked or served they are there. They secrete an oily liquid with an offensive odour that contaminates the food that they do not eat. (They move round)
They are potential carriers of several diseases.
e.g. food contamination and dysentery (signs vary: abdominal discomfort, periodic attacks of diarrhea...)

Fleas, lice, mosquitoes are other insects which spread diseases.

Fig 17.9

E. DICOTYLEDONS.

- Group of flowering plants whose embryos have 2 cotyledons (or seed leaves). They form new wood between the bark and the old wood (exogenous growth) Are often called dicots
- Net-like leaf venation.
- Flower parts in five's.
- Main root stays.

Cotyledons (seed leaves) are part of the embryo, they are large and they have absorbed the food supply for the growing bean seedling.

F. MONOCOTYLEDONS.

- Group of flowering plants whose embryos have only one cotyledon.
- Absence of consecutive layers of wood in the stem (endogenous growth)
- Leaves with parallel venation (banana)
- flower parts in multiples of three (lilies)
- Main root dies.
- Endosperm is separate from the embryo.

Besides the apical meristems, monocots have INTERCALARY MERISTEMS, which produce new cells at the bases of the leaves. A leaf can grow after its tip has been damaged, and it can repair the damage in some extent. (Grass grows even after mowing.)

This mode of growth keeps the developing cells that need most nutrients close to the roots that supply some of these needs.

The young succulent cells are protected by their position, from being eaten by grazing animals.

Monocots are mostly herbaceous (soft bodied, non-woody) annuals or perennials with leaves that die back to the ground after each growing season.

[Perennial = is a plant that produces flowers and seeds more than one time in its lifespan, and therefore lives for more than one year.] E.g. Grasses, cereals, iris.....

18. RELATIONSHIPS OF ORGANISMS WITH ONE ANOTHER AND WITH THE ENVIRONMENT.

A. Energy flow.

The sun is the principle source of energy input to biological systems.

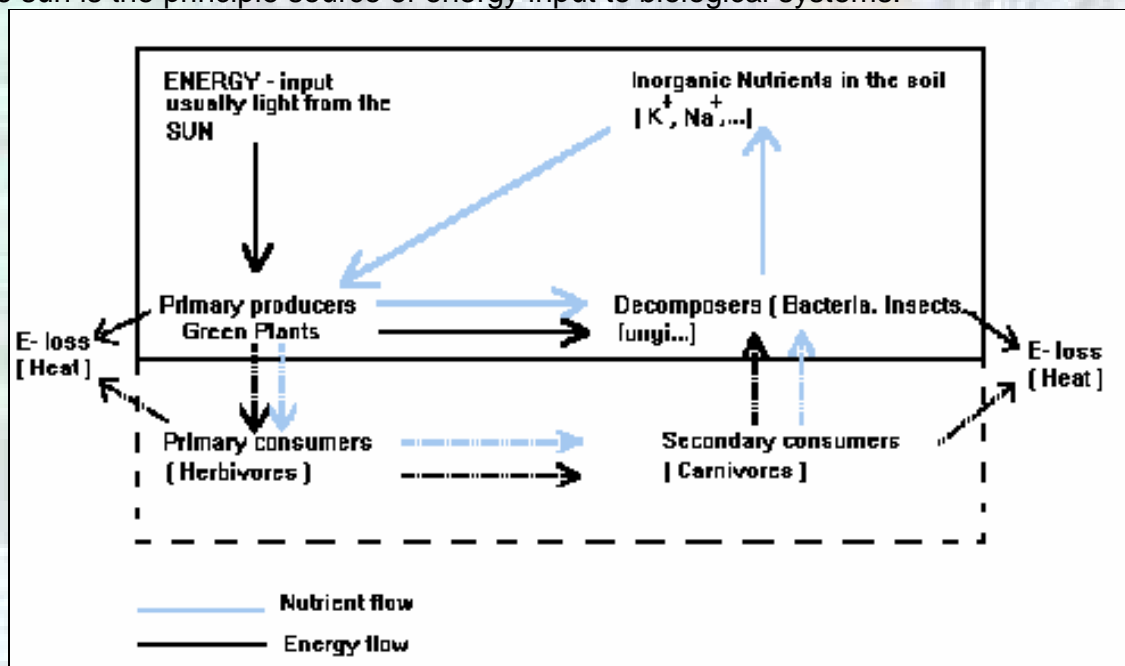

Fig.18.1

Solid box = the basic ecosystem

Solid box + Dotted box = an ecosystem

- Nutrients are cycled through the ecosystem and may be used again and again.
- Energy, by contrast, is not cycled but is continuously lost from an ecosystem. Most organisms would soon die if the sun's energy were cut off.

B. Some definitions.

ECOSYSTEM: all of the organisms (plants, animals, and microbes) present in a particular area, together with their physical and chemical environment. (E.g. Luangwa Park, school grounds, garden, tree...)

FOOD CHAIN: a series of organisms, each of which provides the food supply for the next in line. (E.g. leaves --->caterpillars ---> sparrow ---> hawk)

Created by Bernard Brochez

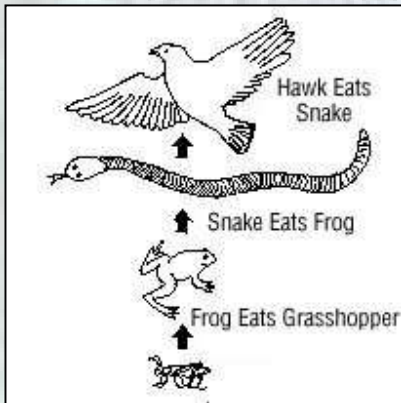

Fig. 18.2

Are rarely isolated sequences, they are usually interconnected with one another, and the overall pattern is a FOOD WEB (may be complex).

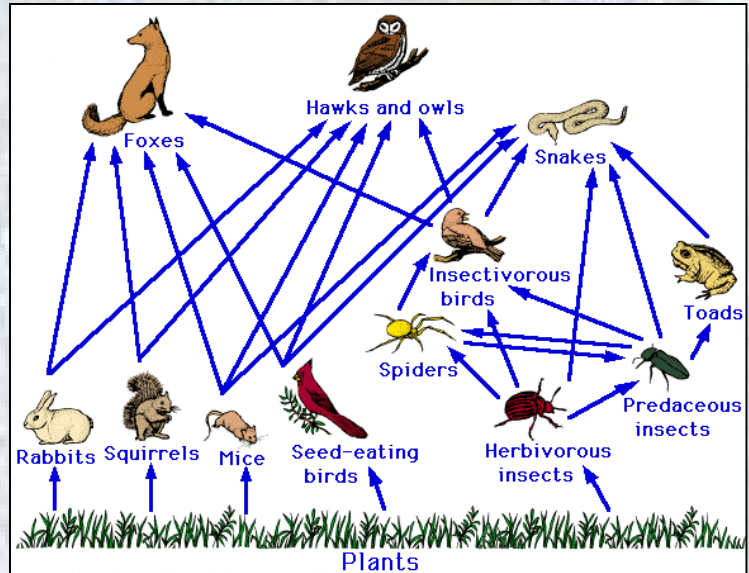

Fig 18.3

PRODUCERS: Photosynthetic and chemosynthetic organisms = autotrophs = make their own food.

(Chemosynthetic organisms use the oxidation of ammonia, sulphides, or iron instead of light as E- source for the synthesis of their organic compounds.)

CONSUMER: organism that eats another organism.

DECOMPOSERS: Organisms that acquire their food molecules from non-living organic material.

TROPHIC LEVEL (T.L.) to which an organism belongs is an indication of how far it is removed from plants in the food chain.

- T.L. 1: Green plants (producer)
- T.L. 2: Prim. consumer (herbivore)
- T.L. 3: Sec. consumer (carnivore)
- T.L. 4: Tert. consumers (carnivores)

It is difficult to give each animal a trophic level. A tadpole for instance eats vegetable material, whilst the adult frog is carnivorous. Plenty animals are omnivores!!

The longer the food chain, the more energy is lost, since there is E-loss (heat) between each trophic level.

There are seldom more than 5 trophic levels in an ecosystem.

Created by Bernard Brochez

C. Pyramids

Because energy is lost at each step (food chain), there are seldom more than five trophic levels in an ecosystem.

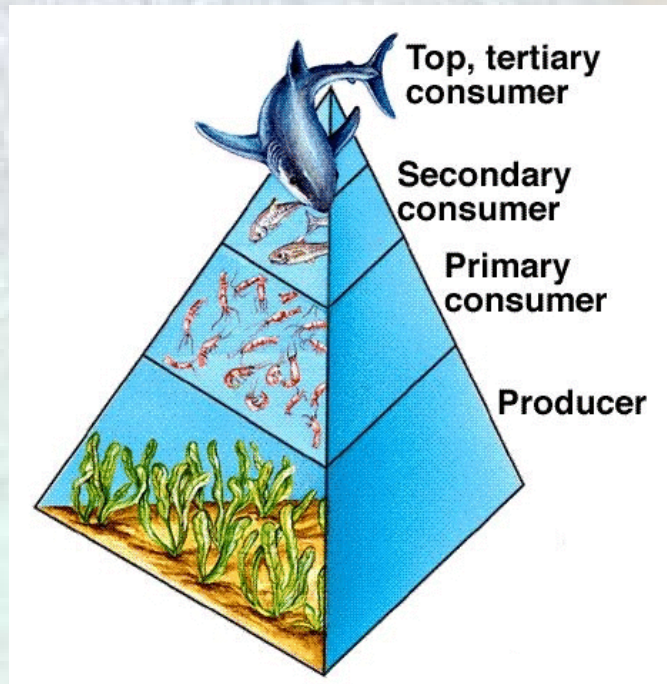

Fig.18.4

A **pyramid of numbers** can be used to depict the progressively smaller numbers of organisms at successive trophic levels.

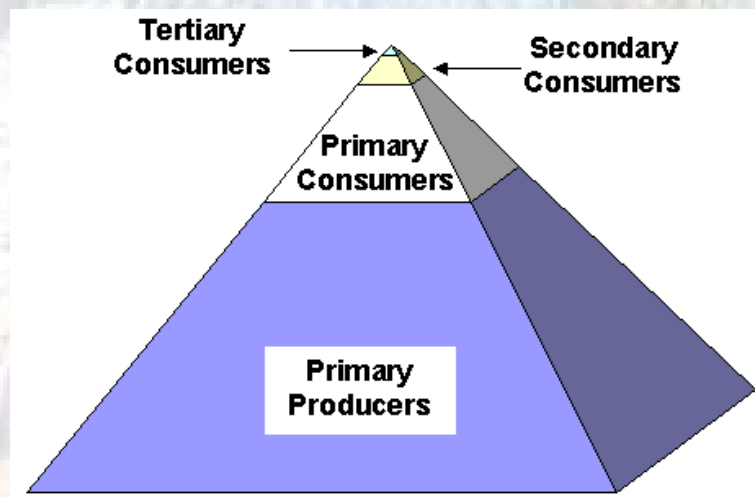

Fig.18.5

Created by Bernard Brochez

Sometimes these pyramids are inverted, for example, when a single tree is attacked by many individual insects.

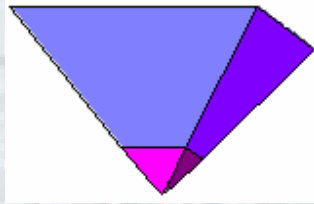

Fig.18.6

C-1. Pyramids of energy.

The flow of energy through an ecosystem can be represented in the form of a **pyramid of energy**, which shows the total amount of incoming energy for successive trophic levels. Unlike pyramids of numbers or biomass, however, pyramids of energy must always be "right side up", because some energy is always lost as heat in going from one trophic level to the next.

In a mature ecosystem, one that is not increasing in biomass, the storage of solar energy in food during photosynthesis approximately equals total community respiration. The rate of energy loss is the same as the rate of energy storage, though lost energy is in a more degraded and therefore less useful form (infrared heat rather than visible light).

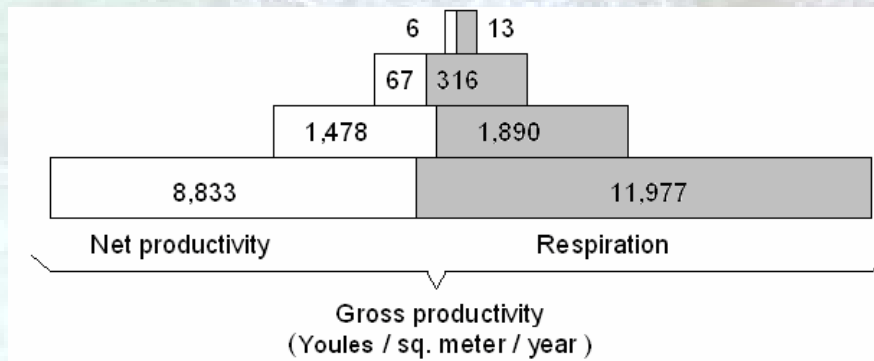

Fig.18.5 River ecosystem

This pyramid of energy shows the total energy input at each trophic level (gross productivity) and its division into net energy gain (net productivity) and energy lost by way of respiration.

D. Energy- loss in an ecosystem.

- Sunlight is used to perform photosynthesis. There is E- build up. That same sun however is also responsible for respiration, which is E-loss.
- Not all the food eaten is actually useful. Herbivores, for instance, need nitrogen to grow. If plants are grown on nitrogen-poor soil, the herbivores will eat more plants and therefore "waste" large amounts of E-rich plant material to extract the nitrogen they need.

Created by Bernard Brochez

- An animal has to feed, look for food. It has to excrete its waste. Metabolism (maintenance and repair of body tissues).

All these activities cost Energy.

Because of the E-loss between the trophic levels, there is not enough E left to support the higher trophic levels.

A wolf for instance has to travel 30 km/day to find enough food. A tiger has a home range of 250 km².

Conclusion:

In terms of Energy, it is better to eat green plants (crops) than instead feed the animals with those crops, and then eat the animals.

E. The Carbon cycle.

Food chains and food webs are but one link in the constant use and re-use of the Earth's chemical resources.

- Green plants perform **photosynthesis**, so the carbon-dioxide is removed from the atmosphere or water in which they grow. The carbon is incorporated into the carbohydrates (sugar, starch) and proteins and pigments. When the plants get eaten by animals, the organic matter will be digested and will become incorporated into animal tissue.
- **Respiration:** Plants and animals get their E by oxidising the carbohydrates to CO₂ and H₂O. This gets excreted and the carbon-dioxide escapes back into the atmosphere.
- **Decay:** Bacteria and fungi use the organic matter of dead animals and plants as a source of E. In the process, CO₂ is produced.
- **Combustion:** Burning C- containing fuels (wood, coal, petroleum..) oxidises the C to CO₂.

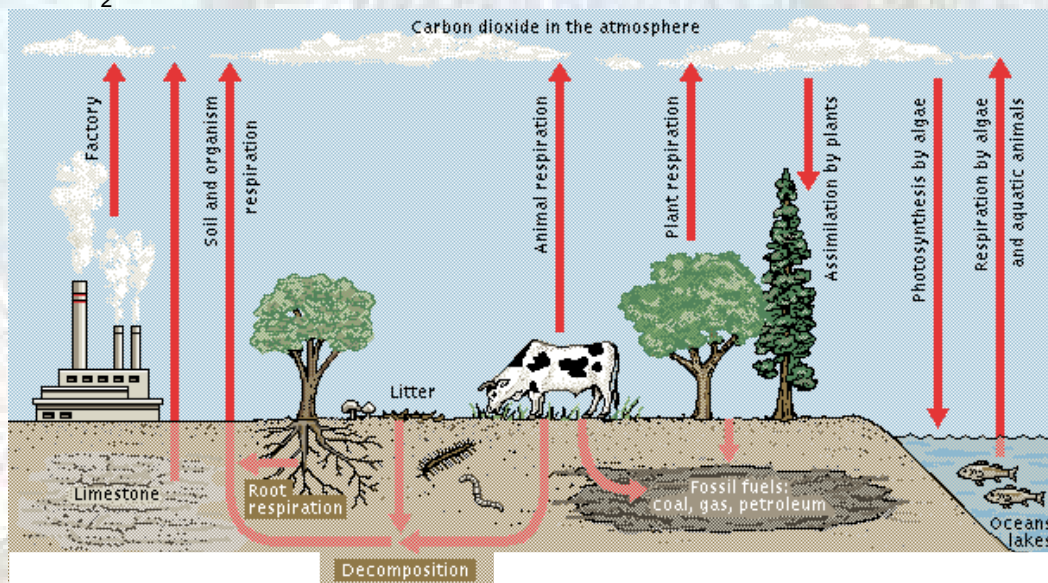
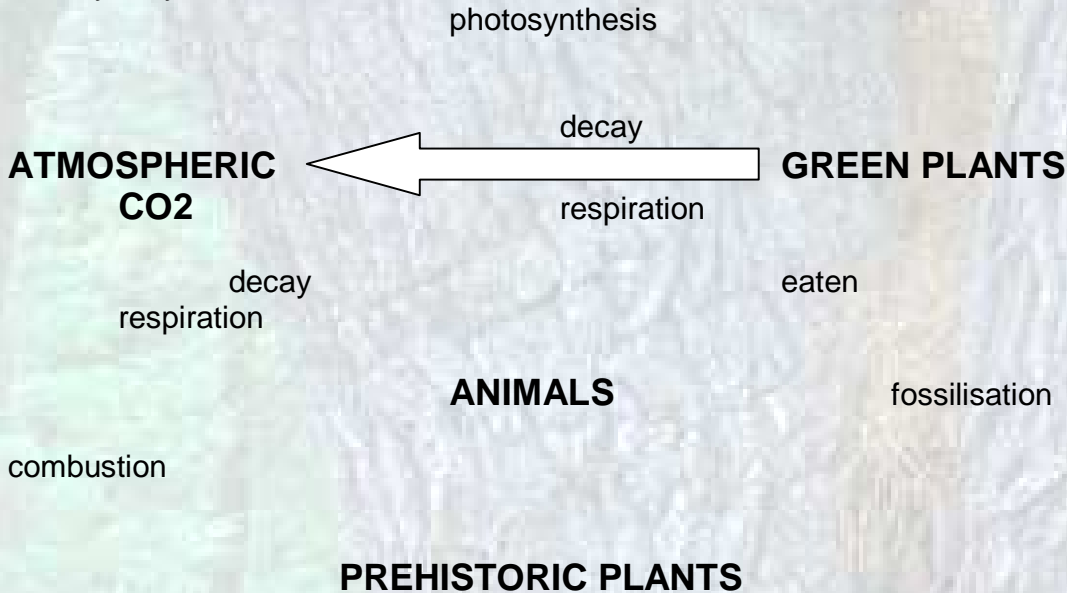

Fig.18.6

Created by Bernard Brochez

Exercise: With the information from the diagram above, complete the simplified diagram of the carbon cycle below by adding arrows. One arrow (decay- respiration) is drawn already for you.



So, if we consider 1 C -atom:

- Today it might be in a molecule of CO₂.
- Tomorrow it can become incorporated into plant tissue.
- If the plant gets eaten, the carbon atom gets incorporated into animal tissue or it is exhaled.
- If not exhaled, the animal will eventually die and fungi and bacteria will start decomposing it.
- Finally the CO₂ will escape into the atmosphere again.

F. The water cycle.

- Animals lose water by evaporation (sweat), defecation, urination, and exhalation.
- They gain water from their food and drink. Plants take up water from the soil and lose it by transpiration. Millions of tonnes of water is transpired, but only a tiny fraction of it has taken part in the reactions of respiration and photosynthesis.

Fig. 18.7



- The great proportion of water is recycled without the intervention of animals or plants:

Created by Bernard Brochez

- The sun shining and the wind blowing over the oceans evaporate water from their vast, exposed surfaces.
- The water vapour enters the atmosphere and forms clouds. Water from these clouds will be lost as rain or snow (precipitation).
- The rain collects in streams and rivers and finds its way back to the oceans.
- Some of this water is used by man for drinking, washing, cooking, irrigation, hydro-electric schemes and industrial processes before it is allowed to go back to the oceans.

(See also your geography notes)

G. Parasitism.

A parasite is an organism that feeds on another living organism without killing it. The animal housing the parasite is referred to as HOST.

- Ectoparasites: attached to the outside of the host (ticks and fleas).
- Endoparasite: lives inside the host's body (hookworm, Roundworms...)

An endoparasite has to have special modifications if it is willing to survive inside the host's body.

In the case of parasitic worms: Since many of those worms live in the host's intestines, they have a protective cuticle which protects them from being digested. They don't even have a mouth or an alimentary canal. The already digested food from man is directly absorbed through their body wall. Some of these worms have suckers with which they attach themselves to the intestine wall. Others have hooks.

Parasite-Host relation.

Normally, the host has no big difficulties in housing its parasite. Sometimes however, there can be damage by the hooks of some parasitic worms or some parasites spread diseases. e.g. Ticks only suck blood from dogs, but they can spread the tick fever.

The parasite is unsuccessful if it does too much damage to the host. For the parasite it is best that the host keeps on living until after the parasite has reproduced many times. Parasitic worms are hermaphroditic: they have both male and female reproductive organs.

In nature, there is a strong selection for those parasites that do not kill their hosts.

The life cycle of the fluke. (just as an example)

Created by Bernard Brochez

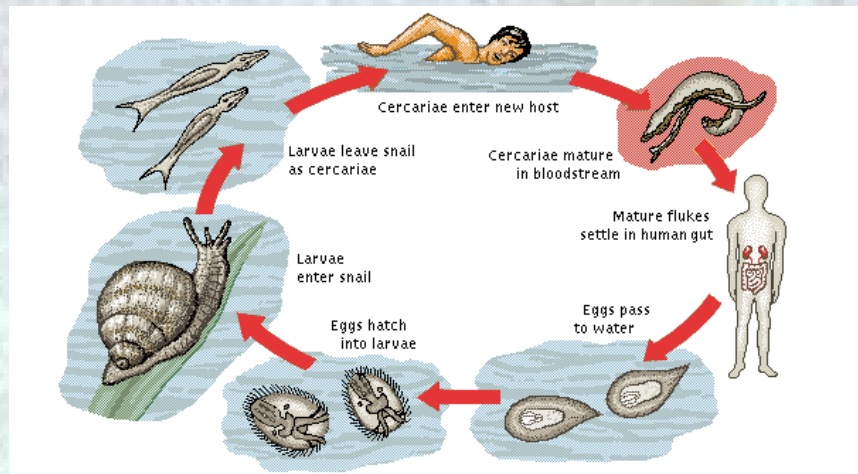

Fig.18.8

G-1. MALARIA.

Is caused by four species of the genus *Plasmodium*.

The two best known are *Plasmodium falciparum* and *Plasmodium vivax*. They are PROTOZOANS

The malaria parasites require 2 different hosts to complete their life cycle.

- Female mosquito of the genus *Anopheles* which transmits the disease, and which is therefore called a VECTOR.
- Human being.



Fig.18.9

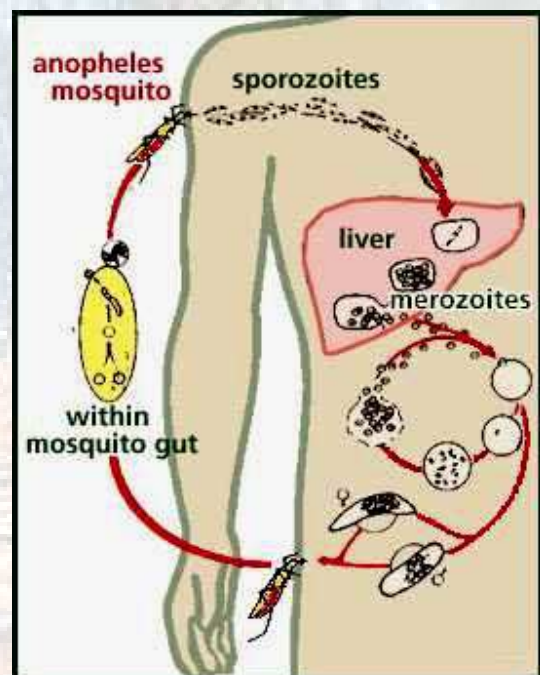

Fig 18.10

The life cycle of Plasmodium

- The mosquito injects saliva + **sporozoites** into the human bloodstream. The female mosquito needs some blood proteins to let her eggs ripen. In the saliva there are enzymes which prevent your blood from clotting.

Created by Bernard Brochez

- The sporozoites migrate to the human liver-cells, where they grow and divide into **schizonts**. The schizonts rupture and release 20,000 or more **merozoites** for each original sporozoite. This period is the *incubation period*.
- Each merozoite invades a R.B.C. and as a result, each invaded R.B.C. sticks to the inner surface of a blood vessel. Since the R.B.C. do not circulate anymore, this protects the parasites from being destroyed in the spleen.
- The parasite repeats the sequence of development into schizonts and merozoites.
- When the R.B.C ruptures, the merozoites invade a new R.B.C. This gives rise to the *typical symptoms of malaria: periodical bouts of fever, shaking, chills and sweating*.
- Some of the parasites in the R.B.C. develop into sexual forms: the **gametocytes**. A mosquito can take them up with a blood meal. Fertilisation will occur in the mosquito's gut. The resulting zygote develops into a cyst in the gut wall and starts growing. After 12-13 days, each cyst releases many sporozoites that will migrate to the salivary glands.

The cycle can now begin all over again.

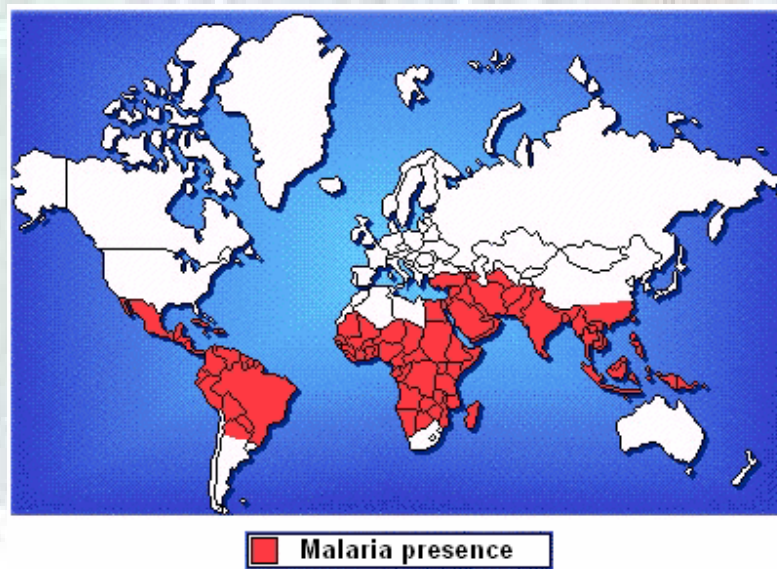

Fig. 18.11

19. EFFECTS OF MAN ON THE ECOSYSTEM.

A. AGRICULTURE.

Definition: Agriculture is the process of producing food, feed, fiber and other desired products by the cultivation of certain plants and the raising of domesticated animals (livestock). The practice of agriculture is also known as farming, while scientists, inventors and others devoted to improving farming methods and implements are also said to be engaged in agriculture

The changeover from hunting and gathering to agriculture has had such a dramatic impact on human societies that it is often known as the AGRICULTURAL REVOLUTION.

The advantages of agriculture are not immediately obvious. For instance, hunters-gatherers do not face the constant battle with pests, droughts and famines that beset all agricultural communities.

The population explosion, which worries us so much today, is a direct result of agriculture.

DEFORESTATION - FOREST and SAVANNAFIRES.

Man has discovered fire a long time ago. Many types of vegetation (savanna...) are set on fire, in order to cultivate the land. This method has advantages as disadvantages. Especially the time on which it is done is very important.

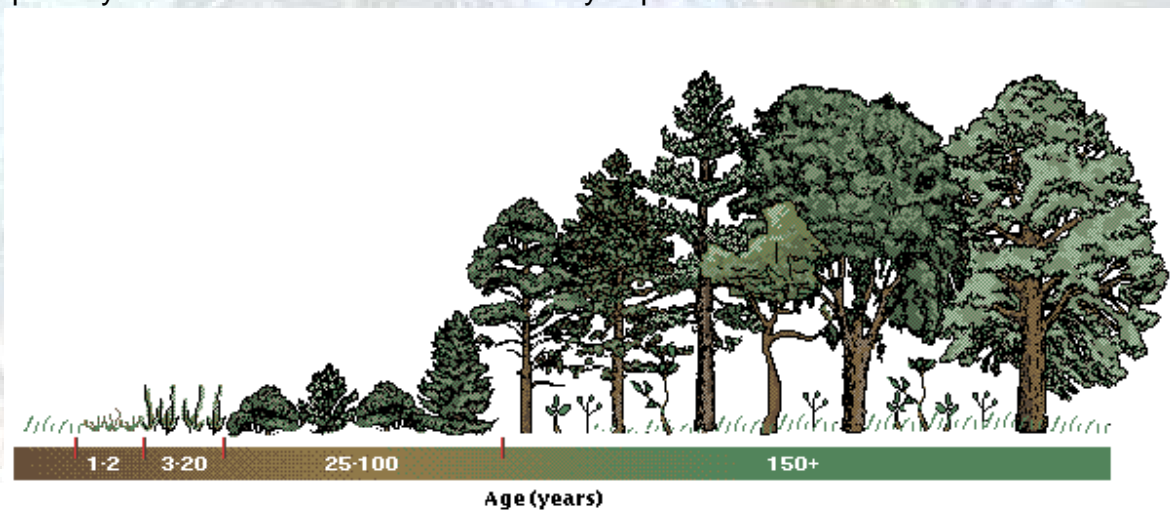
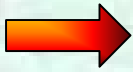

Fig. 19.1 Succession in the Plant Community

Created by Bernard Brochez

A field devastated by fire or cleared for industrial or agricultural use will recover its vegetation relatively quickly in the absence of erosion. In the first years of recovery, bare earth becomes grassland, populated by opportunistic species that can tolerate the bleak environmental conditions. Soon, shrubs and other more competitive plants intermingle and dominate. Tree seedlings crop up, and by the end of the first century a coniferous forest occupies what was an overgrazed or blackened stretch of dirt. The shady forest forms a new environment in which, after another half-century, the seedlings of other kinds of trees may outcompete the initial residents. In this example, the climax community is dominated by deciduous trees. Ecological succession, driven by major environmental change, is an endless and recursive process.

Savanna fires have no natural cause, but they have a strong selective result. Only trees with a thick bark are able to survive.



In the beginning of the dry season it is not so dangerous for the vegetation.



At the end of the dry season, the temperature is much higher, so all life is killed. Only some seeds and underground parts stay alive.

Forest fires are not so selective, since in a forest there are plenty different species present. After the fire, new life can start since plenty species will have survived the fire.

Deforestation



Fig 19.2

Developing or 3-world countries with little export capacity, export their only good: Timber (E.g. Brazil).

Created by Bernard Brochez

The tropical rainforest is being cut at a rate of two football-fields/minute.

A tropical rainforest is considered as the lung of the world. They produce a lot of oxygen and a lot of rain, since the transpiration rate is extremely high.

Plenty rainfall causes the top layer of the soil to be washed away. Rivers look brown from the soil particles and plants in the rivers die (no light, no photosynthesis) Eventually all life in the rivers dies.



Fig. 19.3
The brown colour of the Amazon River

Climates can also change since less rain will be made. Evaporation from seas = 367 mm. Evapotranspiration = 394 mm.
(See water cycle)

Soil stability vanishes since the useful top layer is gone.

In Zambia there has been an uncontrolled business in making charcoal. Since 1990, more and more people are cutting down the trees in order to get some income from the charcoal-business. Whole parts of Southern province already look devastated and soon will become deserted by the people, since there won't be any more possibility to farm.

Scientists note that the overall average temp. on Earth is rising from deforestation and the use of fossil fuels. As a result the conc. of carbon dioxide rises and the ozone layer diminishes. Earth cannot get rid of its heat. Ice on the north and South Pole can melt so areas 5 m. above sea level can get flooded.

We need the ozone layer desperately since it blocks the U.V. rays from the sun. U.V. light is the main cause for skin cancer.

Without a forest and nature, people are forced to migrate towards towns ---> increasing population ---> more cars ---> more garbage ---> more carbon dioxide ---> temp. rises.

Created by Bernard Brochez

Hygienic problems: drinking water, sewage, pollution
(Smokey mountain in Manila (Filippines): rubbish dump which is kept burning to get rid of the dirt.)



Fig. 19.4 Smokey Mountain

EFFECTS ON A GENE POOL (total of all genes present in all members of a population)

Adaptation to an environment is a **MUST**. Some plants and animals will get so adapted to the new conditions that the genetic material will also change. Since environmental factors act as selective pressures, the phenotypic characters that are best adapted to such pressures will also vary in a gradient.

(See also chapter Genetics, selection)

B. POLLUTION

Broadly defined, pollution is any undesirable change in the physical, chemical or biological characteristics of an ecosystem.

All organisms expel their waste products into the environment around them (e.g. carbon dioxide, dead leaves, faeces, inedible parts of plants and animals).

In a balanced ecosystem, one organism's wastes are another's food and drink, so the waste does not accumulate.

Pollution results when human waste products are not destroyed as fast as they are produced and so accumulate, making the environment less hospitable to human and other life.

B-1. WATER POLLUTION.

Most sewage is dumped in rivers, lakes and oceans and it provides nutrients for microscopic green algae as well as bacteria, fungi and protozoa. The algae are particularly useful to man in open "oxidation ponds", which are used in tropical and subtropical countries. The ponds are 1m.-1.5 m. deep and receive raw sewage. The oxygen provided by the algal photosynthesis is vital for the aerobic bacteria that utilise the sewage.



Fig. 19.5

Under certain conditions (warm temp., high availability of nutrients) the algae produce "blooms" = dense masses of material because of rapid increase in population.

There is an explosive growth of primary producers (algae) ---> far more than usual die before being eaten ---> algae decompose, using up the oxygen in the water and resulting in the death of fish.

If blooms happen in reservoirs, they block the filters and the drinking water can have an unpleasant taste

Most blooms occur because we pollute water with phosphates from detergents, nitrates from industry and run-off of excess fertilizers on farmland.



Fig. 19.6

Thermal pollution of water.

This happens because of addition of excessive amounts of heat to a lake.

The production of organic matter in the limnetic zone (upper zone) of a lake depends on the temperature of the water in this zone during summer and on the duration of the warm season.

If extra heat is added (e.g. from power station cooling plant) organic production is increased. Greater production of organic matter means more work for the aerobic decomposers in the hypolimnion (lower zone). A lengthening of the time between the spring and fall overturns may even cause the hypolimnion to use up all of its oxygen before the fall overturn replenishes the supply. The result is the same as above.

Created by Bernard Brochez

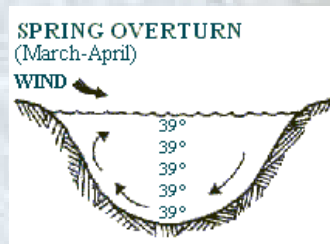

Fig. 19.7

B-2. AIR POLLUTION.

Polluted air is air that damages the health of people who breathe it.

Up to 1950; most air pollution was caused by burning coal. Fogs were a mixture of S, CO₂, CO...

Modern smogs are products of combusting gasoline (cars).

ACID RAIN: is formed when gases such as sulphur dioxide or nitrogen dioxide combine with water vapour.

In each case an acid is formed which falls to the ground in rain. Sulphur dioxide is a waste product of a number of industrial processes (e.g. smelting of ore in mining industry).

Acid rain has become one of the greatest environmental problems of our time. It harms wildlife and damages crops, forests and buildings.

It is an international problem since winds blow the gas clouds way over the national frontiers.

B-3. POLLUTION FROM INSECTICIDES.

People (farmers) are using too much herbicides and insecticides which are not biodegradable to battle pests.

E.g. D.D.T. (Di-chloro-Di-phenyl-Tri-chloro-ethane).

It kills body lice and mosquitoes so it has saved thousands of lives (malaria and typhoid)

The used conc. seemed harmless to man and other animals. In higher conc. it was known to be poisonous to fish.

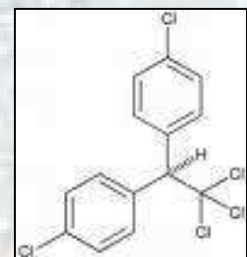

If DDT is taken in with food or water, it is not all eliminated from the body. A proportion is kept and accumulated in the fat deposits of the body. Animals at the end of the food chain are most vulnerable.

Created by Bernard Brochez

At a conc. of 0.015 ppm. in lake water the fish were unharmed, but after 5 yrs. they started to die.

Although the water only contained 0.015 PPM., the plankton had accumulated it up to 5 ppm. Small plankton eating fish had up to 10 ppm. Predatory fish had even higher conc. The fish eagle is affected most since DDT in its body makes the females to lay eggs with thinner shells. When the birds land on the nest, the eggs break.
(ppm = parts per million)

C. FAMINE.

The population explosion (every year there are 50 million more people), deforestation, the unequal distribution of food, pollution, droughts (Studies have shown that the rainfall in Ethiopia, Sudan and Chad has been declining for the last 200 years) and floods as a result of the changing climates all contribute to the problem of famine. Famine strikes many developing countries every year, and many people (children) die of starvation and diseases.

Some developing countries use their best quality land to grow cash crops like coffee and tea. These crops have no food value, but are exported to earn foreign currency.

D. CONSERVATION.

There is a desperate need for new environmental policies. Instead of destroying nature we have to conserve and treasure it.

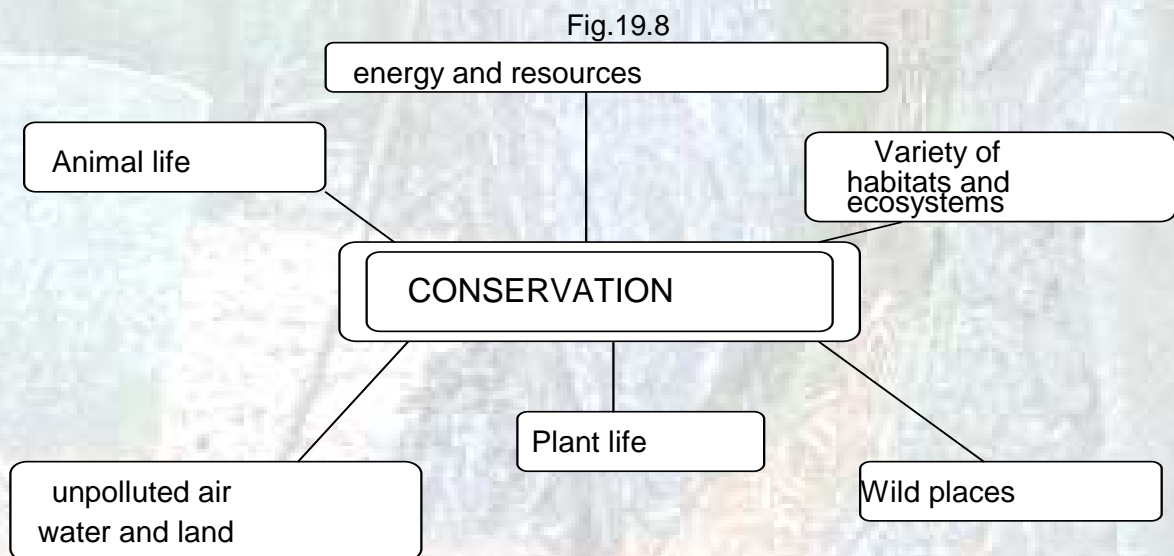

We have to get more knowledge about nature:

- Several plants are used to get extracts from which many drugs are made.
- Peyote cactus = source of mescaline.
- Seeds of the Morning Glory have hallucinogenic effects.

Created by Bernard Brochez

- Many people by tradition know how to use herbs for curing some diseases, cleaning wounds, break fever... (umunsokansoka)
- Many plants are used to dye fabrics...
- Trees supply enough timber for furniture, paper,...
- Several oils are secreted by plants which find their use in several fields (e.g. perfume...)
- Rubber trees produce rubber (tyres)

Many species have not been studied yet. Plants as well as animals. Who knows what hidden secrets (cures) some of them may house? For example: genetic tests have proven that crossing a wild grass with a strain of wheat produced an improved variety.

Today some 25 000 plant species are threatened with extinction. This could lead to a devastating loss of hereditary material (genes) and a reduction of about 10 % in the genes available for crop improvement.

“Gene banks” have been put up, but these are vulnerable to accidents, human error...

Some steps in the right direction come from organisations such as W.W.F. (World Wide Fund for Nature), Greenpeace, IWC (International Whaling Commission) and new laws like CITES (Convention on International Trade in Endangered Species).

E. Treatment of sewage

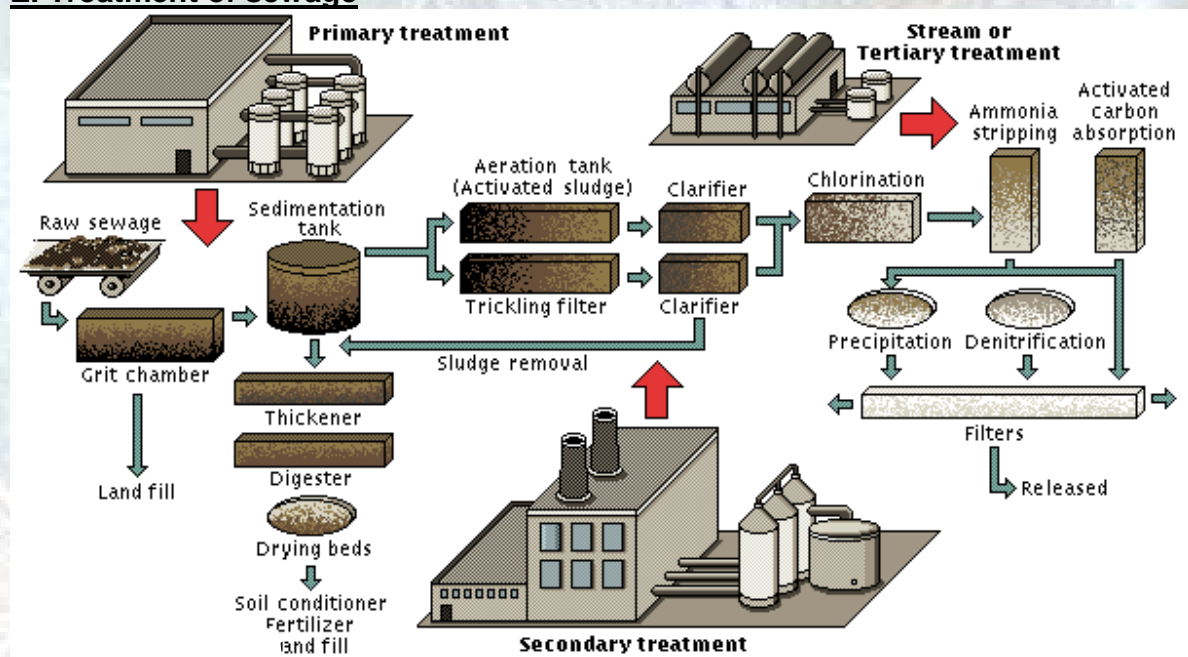

Fig. 19.9 Wastewater Treatment

Created by Bernard Brochez

Raw sewage includes waterborne waste from sinks, toilets, and industrial processes. Treatment of the sewage is required before it can be safely buried, used, or released back into local water systems. In a treatment plant, the waste is passed through a series of screens, chambers, and chemical processes to reduce its bulk and toxicity. The three general phases of treatment are primary, secondary, and tertiary. During primary treatment, a large percentage of the suspended solids and inorganic material is removed from the sewage. The focus of secondary treatment is reducing organic material by accelerating natural biological processes. Tertiary treatment is necessary when the water will be reused; 99 percent of solids are removed and various chemical processes are used to ensure the water is as free from impurity as possible.

F. RECYCLING.

Recycling is the re-using of materials from which products are made (Newspapers, beer cans...) or the re-use of the products themselves (glass bottles...)

Below in the table you can see how much household waste is produced per country and the equivalent amount per person.



COUNTRY	ANNUAL DOMESTIC WASTE (tons)	EQUIVALENT PER PERSON (kilograms)
Australia	10,000,000	680
Belgium	3,082,000	313
Canada	12,600,000	525
Denmark	2,046,000	399
Finland	1,200,000	399
France	15,500,000	288
Great Britain	15,816,000	282
Italy	14,041,000	246
Japan	40,225,000	288
Netherlands	5,400,000	381
New Zealand	1,528,000	488
Norway	1,700,000	415
Spain	8,028,000	214
Sweden	2,500,000	300
Switzerland	2,146,000	336
United States	200,000,000	875
West Germany	20,780,000	337

Fig. 19.10

F-1. Water.

Water from the tap has been purified to make it fit for consumption.

- It has been filtered through beds of sand to remove suspended solids and to allow bacteria, living in the sand, to remove harmful impurities.
- It will have had chlorine added to it. This oxidizes other impurities that might give bad tastes and smells and disinfects the water by killing any bacteria.

Created by Bernard Brochez

Other possibilities:

- It may be passed through activated carbon to remove org. compounds that give the water taste, colour and smell
- and
- It may have had oxygen bubbled through it to oxidize other impurities.
- People shouldn't take water just for granted. Take a shower instead of a bath. You'll save up to 100 l.

A leaking tap spills 200 l. a day!!!!

Food for thought:

Imagine Shopping Malls like Manda Hill and Arcades having underground water storage facilities. Do you know how much rainwater could be stored during the rainy season in Zambia?

Let us have a look at Manda Hill and Arcades from above.



Fig. 19.11 Manda Hill



Fig. 19.12

Adjacent you see College

Arcades

the FTJ. Chiluba

A rough estimation of the measurements of those two massive shopping malls gives us total roof surface areas:

Created by Bernard Brochez

For Manda Hill about 6,5000 m²
For Arcades about 3,500 m²

Knowing that the average rainy season in Lusaka yields about 750 mm,
(Source: <http://www.zambiatourism.com/travel/hisgeopeop/geograph.htm#Rainfall>) we can easily calculate how much water could be stored.

$$6,500 + 3,500 = 10,000 \text{ m}^2 \times 750 \text{ l/m}^2 = 7,500,000.00 \text{ liters.}$$

Agreed, this water is not treated nor purified and therefore not potable. It can be used however to bathe, flush toilets, water flowers, laundry,...)



Fig. 19.13

F-2. Paper

Newspapers and magazines can be used again and again, if only people allow it.

- The used paper is soaked and washed to remove the ink. The ink is collected in a separator.
- The soaked and cleaned mass is then dried and is pressed to make large sheets.
- Recycled paper is greyish or at least darker in colour. If it has to be white, the papermass is washed in chlorine solutions to extract the colours of the cellulose-fibres. This process of course gives new pollution since the chlorine compounds remain in the washing water.

Created by Bernard Brochez



Fig. 19.14

F-3. Material.

If it is worthwhile to collect and recycle a particular material remains an economic decision, and what is uneconomic today may become economic within 5 years when the material becomes very expensive.

Sometimes the cost of collection is more than the saving by recycling:

E.g. Glass. Glass is made up of silicates, and the raw material is plentiful. It needs less energy to melt glass to use again than to make new glass. However, collection and transport cost more than the company can save.

In the western world, consumers are encouraged to bring their glass to central places where there are glass containers.

- Metal objects containing 2 or more metals cannot be easily recycled, as the metals must be separated. Beer and soft drink cans are mostly made up of 3 metals.

Some metals are, when used, so finely spread over the Earth that their recycling is impossible (e.g. Lead in petrol)

20. ASEQUAL REPRODUCTION.

= Any means of multiplying that does not involve both eggs and sperm.

Many unicellular organisms reproduce asexual simply by dividing into 2 identical smaller cells (e.g. bacteria)

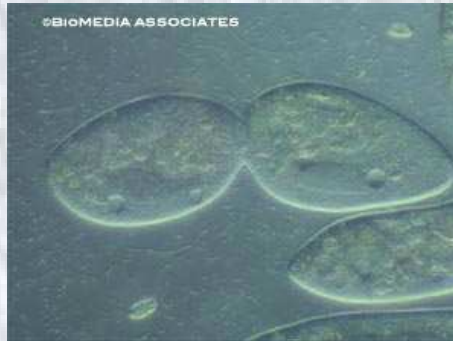

Fig. 20.1
Paramecium dividing in two

Many plants can reproduce without gametes, pollination and fertilisation. This form of asexual reproduction is also called **vegetative reproduction**.

Asexual reproduction in some lower invertebrates occurs by **BUDDING OFF** of smaller individuals, which eventually detach from the parent (e.g. Hydra = freshwater anemone)

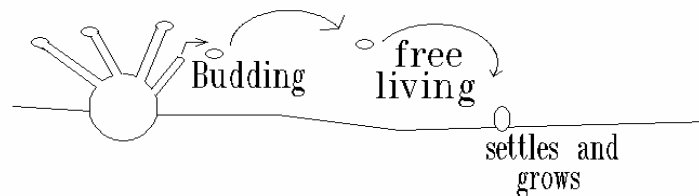

Fig. 20.2

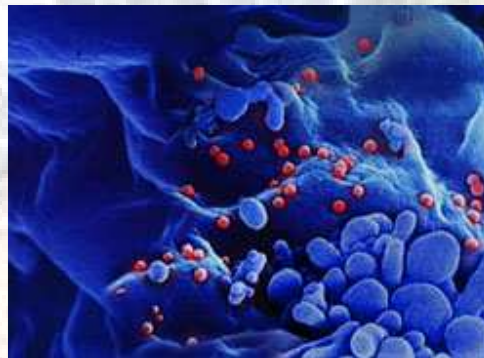

Fig. 20.2
HIV virus particles budding off from the surface of an infected immune system cell

Created by Bernard Brochez

Many plants also form new individuals attached to the parent plant that break off and start life on their own when they have become large enough (e.g. strawberry makes stolons).

Stolon = runner, an outgrowth of a lateral bud.

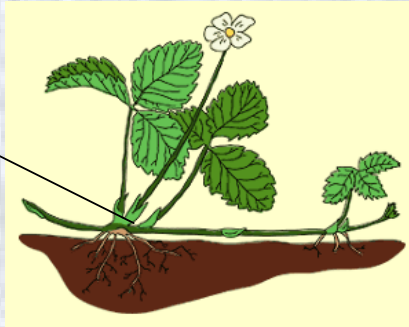

Fig. 20.4

In some organisms, unfertilised eggs give rise to new individuals. In animals this is called **parthenogenesis** (parthenos = virgin), in plants it is called **agamospermy** (a = without; gamos = marriage; sperma = seed, hence: seed without marriage).



e.g. of parthenogenesis:

Aphids = sap sucking insects.

In summer many unfertilised eggs develop in the mother's body and are born as miniature versions of her. Overcrowding for example can cause the laying of eggs, which develop into winged males and females that disperse to new locations.

Fig. 20.5

Plants can make underground, horizontal stems, **rhizomes**. At the nodes of the rhizome are buds, which may produce shoots above the ground (e.g. grasses)

Daffodils make bulbs, very short shoots. The stem is only a few mm. long and the leaves, which encircle the stem, are thick and fleshy with stored food. In spring, the stored food is used by a rapidly growing terminal bud which produces a flowering stalk and a number of leaves. In the growing season, food made in the leaves is sent to the leaf bases and stored. The leaf bases swell and form a new bulb, ready to grow next year.



Fig. 20.6

Created by Bernard Brochez

Why is asexual reproduction still so successful?

- It saves a lot of energy. There is no need to spend energy to look for partners, to make a lot of gametes...
- A plant reproducing vegetatively is, itself, already in a situation favourable for growth. So the offspring should do fine also.

Commercial importance.

Daughter plants produced vegetatively, are all genetically identical with each other and their parent, i.e. they form **clones**. There will be no variation between individuals. In agriculture and horticulture, this has the advantage that all the good characteristics of a crop plant, such as potato, can be preserved from generation to generation.

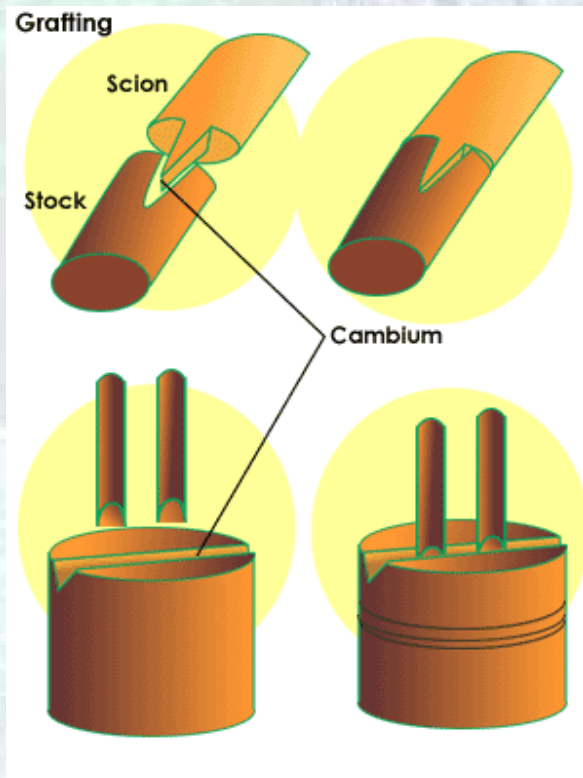

Cuttings: produce new individuals from the cut end of a shoot.

The cut end is put in water or moist soil. Roots will start growing from the base of the stem (treat with "rooting hormone").

Grafting: A bud or shoot from one plant is inserted under the bark on the stem of another, closely related, variety. The rooted portion is called the **stock**; the bud or shoot being grafted is the **scion**

Fig. 20.7

BIOTECHNOLOGY: Some plants make their own insecticide. We can now take that gene out of the plant and insert it into a, for us people, more interesting plant (tomato, cabbage...)

Once you have engineered a plant to, let's say, make its own insecticide. You can use that same plant to grow many more individuals, all of which will have the same characteristics, including the gene for the production of its own insecticide.

21. SEXUAL REPRODUCTION IN PLANTS

A. Typical flower structure.

Sepals:

- usually green; if not green, they have a colour different from the petal colour.
- usually small; they protect the flower parts before the flower opens.
- sometimes they drop (e.g. poppy)
- can be single or connected to each other.

Petals:

- usually bright coloured (insect attraction).
- can be single or connected to each other.

Stamen:

- consists of filament and anther.
- are the male structures of the flower.
- the anthers produce pollen.

Carpels:

- are modified leaves that contain the ovules.
- are the female structures of the flower

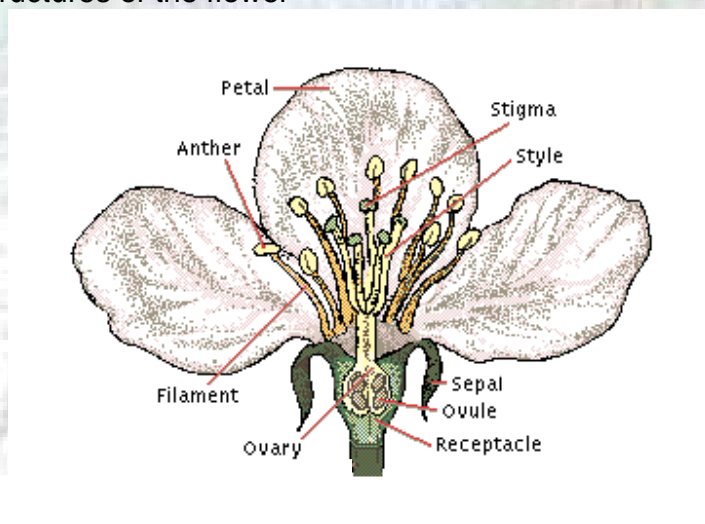

Fig. 21.1

- consist of three parts:
 - stigma: often covered with a sticky substance (to which pollen grains adhere).
 - style
 - ovary: encloses one or more ovules in which the tiny female gametophyte develops.

Created by Bernard Brochez

[In plants, meiosis gives rise to spores, rather than gametes, which are the products of meiosis in animals. The haploid spores grow into haploid gametophytes, which in turn produce the gametes that take part in fertilisation.]

[gametophyte = haploid plant that produces haploid gametes by mitosis. Land plants are often called embryophytes because the zygote remains within the parent plant as it develops into an embryo].

B. Pollination and fertilisation.

Pollen grains are put on the stigma by wind or an insect. The pollen grain produces a pollen tube which grows down the style and into the ovary, where it releases **two haploid sperm nuclei**.

These two nuclei take part in a **double fertilisation** (unique to flowering plants).

- One sperm nucleus fertilises the egg nucleus to give rise to a 2 N (diploid) zygote.
- The other sperm nucleus fertilises the polar nuclei, which results in a 3 N endosperm nucleus, which then rapidly divides giving rise to a triploid nutritive tissue: **the endosperm**.

As the zygote develops into an embryo, the endosperm absorbs food from the parent sporophyte, and the layers of the **ovule wall** develop into the **seed coat**. The **ovary wall** develops into the **fruit**.

[Sporophyte = Diploid plant that produces haploid spores following meiosis].

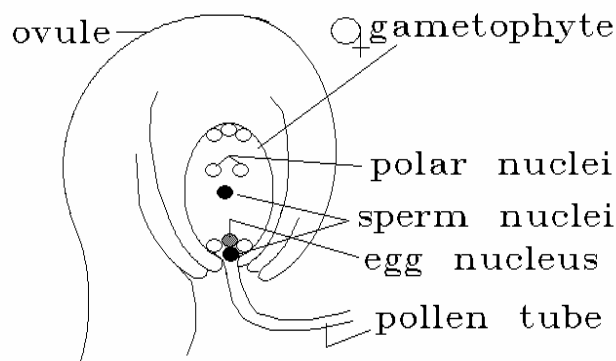

Fig. 21.2

Pollination = the deposition of pollen on or near the female parts of a flower.

Pollen may simply fall from the anther onto the stigma of the same flower, resulting in **self-pollination**. (E.g. peas have modified petals to ensure self-pollination).

Created by Bernard Brochez

Although many types of flowers do self-pollinate, it is often genetically desirable for plants to be **cross-pollinated**, that is, to receive pollen from another individual of the same species.

Many plants have adaptations that ensure cross-pollination:

- a flower's carpels may mature only after its anthers have shed their pollen.
- the existence of separate male and female plants or flowers is probably due to selective pressure for cross-pollination.

Pollen cannot move on its own power; plants rely on **wind or animals** as agents of pollination. From a plant's point of view, pollination by animals may have advantages over pollination by wind.

- Wind pollination is wasteful because much of the pollen may never reach another flower. A plant may save energy on pollen production if it is pollinated by animals.
- Wind pollination is very inefficient for a plant that does not live in dense populations. By contrast, an animal which only visits one type of plant will carry pollen directly from one individual to another of the same species.

Some plants or flowers have therefore developed structures such that only one species of animal can pollinate them.

Animal pollinators are attracted by some type of reward, usually a **sweet nectar** -- and second, by an advertisement, such as **odour, shape or colour of a flower** (preferably all three) -- that catch the animal's attention.

The reward of course is so located that the animal cannot reach it without at the same time acquiring a load of pollen.

All this of course has a cost: the animal-pollinated flower must invest energy in making its nectar and its large, showy petals.

Animals that serve as pollinators include insects (bees, butterflies, moths, wasps, flies and beetles) and vertebrates such as birds, bats, and even a South African mouse.

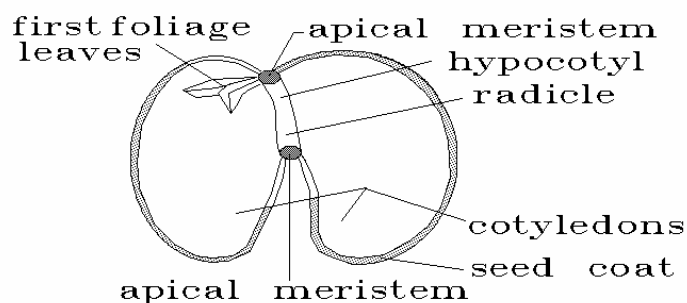

Fig.21.3

Created by Bernard Brochez

C. Seeds.

Non-endospermic seed.

C-1. Embryo:

Radicle:

Is the embryonic root which grows and develops into the root system of the plant.

Plumule:

Is the leafy part of the embryonic shoot. Leaves are attached to the embryonic stem: part of the stem above the attachment of the cotyledons = EPICOTYL. Below the attachment = HYPOCOTYL.

Cotyledons:

are modified leaves attached to the epicotyl and hypocotyl by short stalks.

They often contain food reserves (used in early stage of germination).

They fall off, normally after the first foliage leaves are formed. These leaves are completely different from the cotyledons.

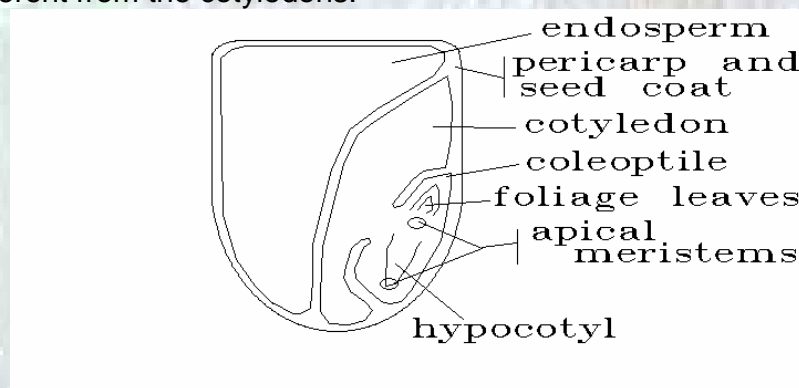

Fig. 21.4

C-2. Testa or seed coat:

The integuments round the ovule form the testa, a tough hard coat which protects the seed from fungi, bacteria and insects.

It splits open by the radicle and germination can proceed.

The seed + seed coat are protected by the pericarp. The pericarp is a part of the fruit which is closely attached to the seed coat, so that the two peel off together as the "skin" of a kernel of corn.

FRUIT: structure formed from the ovary of a flower around one or more seeds.

D. Dispersal of seeds and fruits.

Once seeds mature, they are ready for dispersal.

Created by Bernard Brochez

- Small lightweight seeds and dandelion fruits have parachute-like tufts of fibre that enable them to float on the breezes for dispersal through the air.
- Some exotic plants make hang-gliders for their seeds to float on the slightest breeze.
- Larger seeds have a distinct competitive advantage because they contain more food to supply the embryo's needs until it becomes established. These seeds have to be dispersed by animals, which may carry them over a considerable distance.
- Plenty plants put in a lot of energy to protect their seeds. Most common investment is the indigestible seed coat. Seeds are surrounded by a tasty, nutritious fruit that an animal will eat. The seeds pass unharmed through its gut and are deposited with a small pile of organic fertiliser.
- Some seeds cannot germinate, until after they have been partially broken down by the animal's digestive enzymes.
- When fruits are not ripe, they taste sour and sometimes even have toxic chemicals. The colour and taste change when the fruit ripens ----> animal attraction.
- Some seed and fruits have hook-like extensions that attach to feathers, fur or clothing, which give the seed a free ride.
- Some seeds can survive for many years. E.g. The coconut of the Seychelles can float on ocean currents, until it washes ashore.

By all these characteristics, plants are able to colonise new areas, and survive as a species.

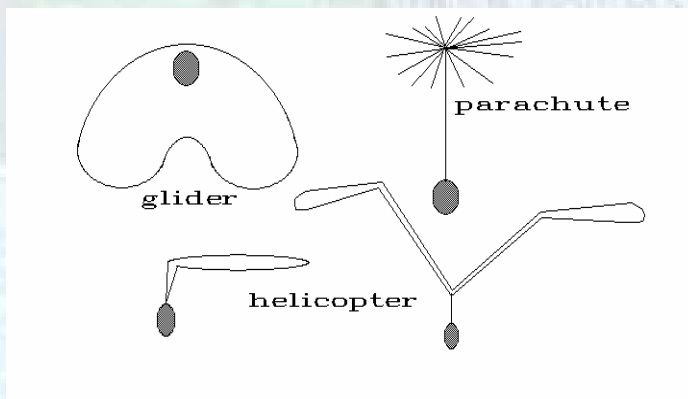

Fig.21.5 Different seed shapes

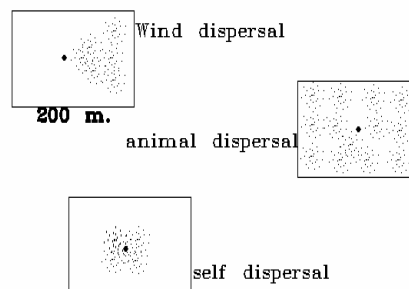

Fig.21. 6 Ways of dispersal

Created by Bernard Brochez

E. Germination of seeds.

In order to germinate, or begin growing into a new plant, seeds must be supplied with **water**. However, the seed coat is often so thick or impermeable that its contents cannot absorb water until the seed has had some special treatment. The seed coat may need to be partially digested by animals or decomposer organisms before water can enter.

Most seeds also require **oxygen** and many require **particular temperature and light conditions** before they will germinate.

Furthermore, germination requirements may vary not only from species to species, but also from individual to individual.

Germination may be spread over months or years, and at least some seeds are likely to find conditions that favour their survival.

(See also: Chapter Enzymes: Enzymes and germination of seeds)

22. SEXUAL REPRODUCTION IN MAN.

The crucial event is **FERTILISATION**, the union of 2 haploid reproductive cells, the **GAMETES**, to form a diploid **ZYGOTE**.

In animals, the gametes are always different from each other:

Female gamete: large, non-motile egg cell (or ovum) (swollen with food + other molecules needed to support embryonic development) An ovum is hundreds of times bigger than a sperm-cell, and they appear in smaller numbers. (ranging from 1 to 10)

Male gamete: a motile sperm, which actively moves towards the egg. To do so, it is using its tail. Are produced in bigger numbers (millions).

In mammals, the ovum produces a chemical which attracts the sperm-cells.

After fertilisation, the zygote undergoes a period of embryonic development before it is born or hatched.

EXTERNAL FERTILISATION: The female lays eggs, and the male fertilises them with his sperm. This happens outside the body.
(e.g. fish, amphibians).

INTERNAL FERTILISATION: The ova (plural of ovum) are fertilised inside the female's body.

- **Reptiles, birds:** as soon as the ova are fertilised, eggs are laid without further development.
- **Mammals:** the ova are fertilised and remain in the body for further development.

HERMAPHRODITIC ANIMALS:

These have both male and female reproductive organs. 2 individuals line up and while transferring their sperm, their ova get fertilised from the partner. (e.g. earthworms, snails). Some individuals change their sex during their lifetime. First they are males, later on they become females (e.g. Blueheads = type of fish)

Internal fertilisation has many advantages: The female reprod. tract provides a protected space where sperm and ovum can fuse without danger of being eaten or being washed away. The sperm can find the ovum quite well (chemical attraction)

The embryo gets enough moisture and all the right chemical conditions. For mammals, the embryo gets warmth as well.

HUMAN REPRODUCTIVE ORGANS

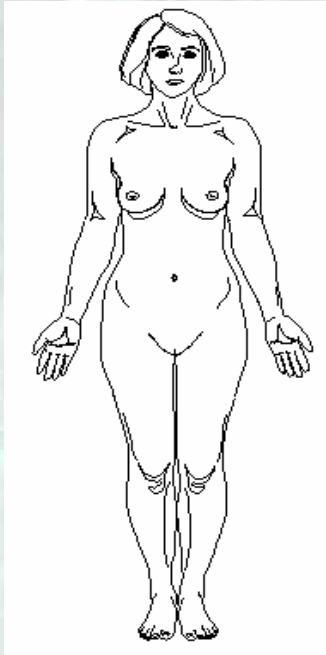

Fig. 22.1

NOTE: opening of urethra (urinary tract) and of the vagina (reprod. tract), are separate (only with females of the higher mammals.)

A. FEMALE REPRODUCTIVE ORGANS.

A-1. External sex organs (= vulva)

- **Labia majora and minora** (= major and minor lips). They cover and protect the urinary and genital openings and the surrounding tissue.
- Girls are born with a membrane: the **hymen**, covering the vaginal orifice. One or more slits in the hymen allow the menstrual flow to pass.
- **Clitoris**: Develops from the same structure that develops into the penis in a male embryo. Its only function is to give a pleasurable sensation when it is stimulated by touch.
- **Mons Veneris** (= "Mountain of Venus"). A fatty pad over the pubic bones.

A-2. Internal reproductive organs

Consist of the ovaries and oviducts (fallopian tubes), uterus and vagina.

- The **2 OVARIES** are the female GONADS (= gamete-producing organs) which produce the ova.
 - Girls are born with all the (immature) ova they will ever have. (approx. 1,000,000 at birth).
 - Approx. 700,000 die before puberty, and most others die during the next decades. Only 400 to 500 are ovulated before the woman's reproductive life ends at the menopause.
- The ovary contains many follicles (= immature ovum, surrounded by nutritive follicle cells).
- Ovulation: a mature follicle ruptures and the ovum pops out into the coelom (inner space or cavity of the body). The finger-like endings of the **oviduct** reach and grasp the ovum.
- Cilia draw the ovum into the oviduct and on towards the uterus.
- Fertilisation usually occurs halfway the oviduct.

Created by Bernard Brochez

- **UTERUS:** a highly elastic organ. Its main function is to hold a developing embryo and expel it during childbirth. The non-pregnant uterus has the size and shape of a pear.
- The external opening of the uterus = **CERVIX**, made up of the biggest, most powerful sphincter muscle in the body. It is capable of holding 6-7 kg. of foetus and fluid in the uterus against gravity.
- **VAGINA:** receptacle for the penis during copulation (sexual intercourse), and the pathway to the exterior for the baby during birth. It has extremely elastic walls.

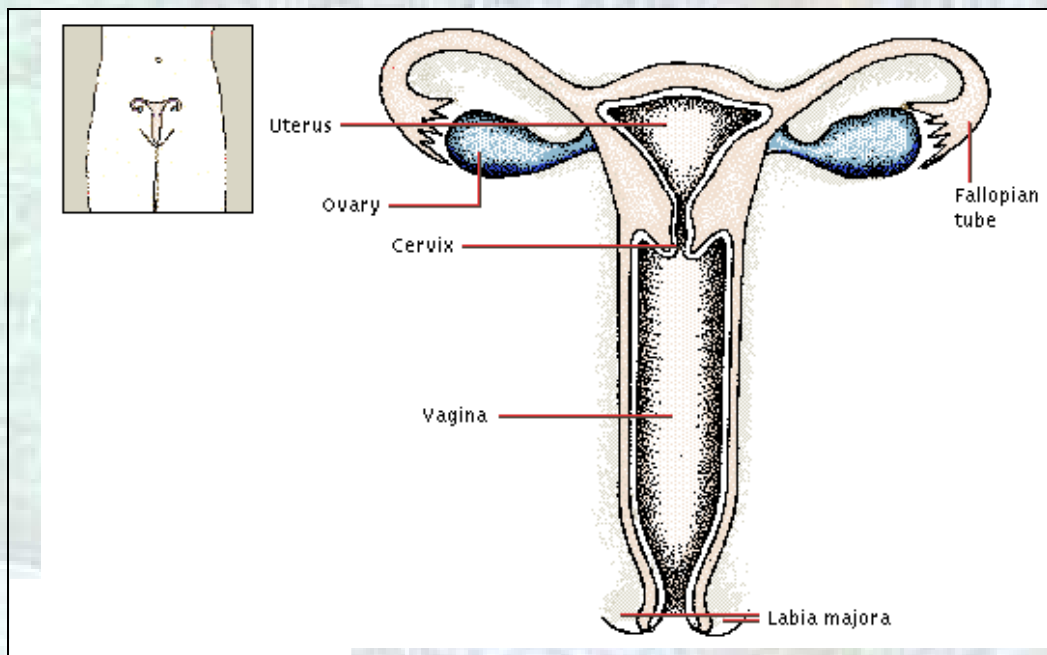

Fig. 22.2

B. MALE REPRODUCTIVE ORGANS.

- The gonads of a male are the **TESTES** (sing. testis). They produce spermatozoa (sperm), from the time of sexual maturity (puberty) until death.
- Sperm production in mammals requires a lower temp. The testes therefore lie in the cooler **SCROTUM**, a sac outside the body cavity.
- Sperms are produced from cells lining the seminiferous tubules in the testes. An immature sperm is carried to the **EPIDIDYMIS**, where they are stored for final maturation.
- During sexual stimulation, sperm move through the **vas deferens** (vasa deferentia) by contractions of its walls. The sperm reaches the **seminal vesicles**.

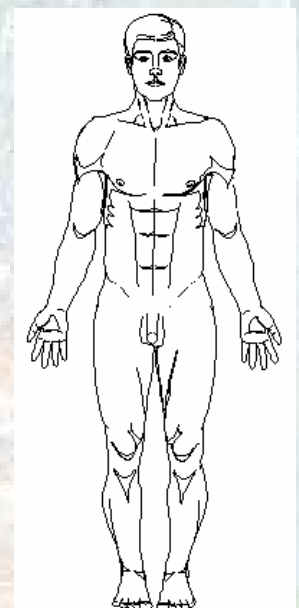

Fig. 22.3

Created by Bernard Brochez

Sperm now moves into the urethra, and are joined by secretions from the seminal vesicles and **prostate and Cowper's glands**.

Sperm + secretions = **SEMEN**. It leaves the penis via the urethra.

The penis is the external sex organ that introduces semen into the vagina during intercourse. (Urine leaves the body by the same route, but the 2 fluids cannot pass at the same time).

The penis consists of erectile tissue. Erection occurs when the blood spaces are filled with blood.

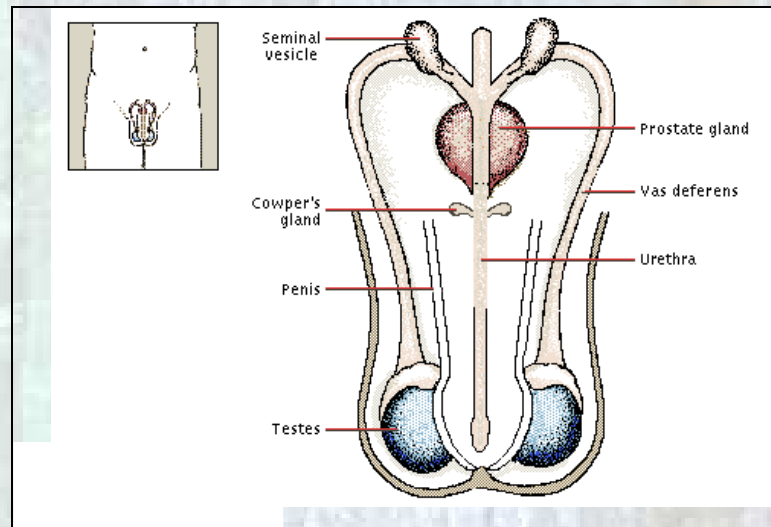

Fig. 22.4

C. PHYSIOLOGY OF SEXUAL INTERCOURSE.

During sexual intercourse, the penis introduces sperm into the body of the female. Before entering the vagina, the penis must become at least partly erect by sexual stimulation (Mostly touch.....)

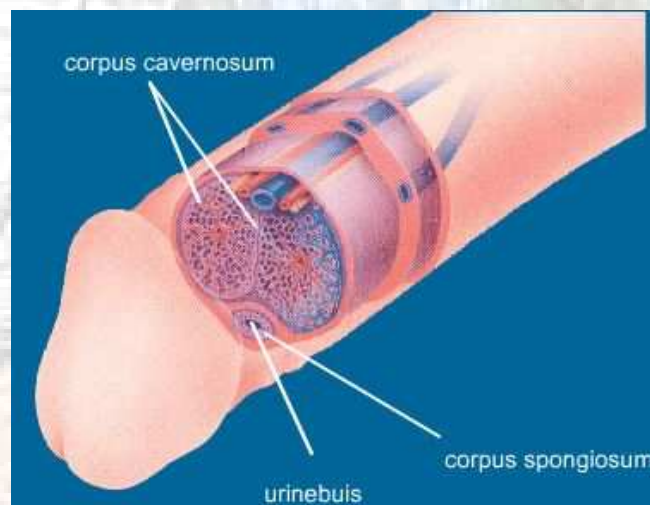

Fig. 22.5

Created by Bernard Brochez

The penis consists of three cylinders of spongy tissue that extend into the body. Cells within the cylinders contain many hollow bodies, usually empty and collapsed. During sexual stimulation +/- 10 times the normal volume of blood is carried from the arteries into these hollow bodies. The blood filling the spaces presses against the outside of the veins, narrowing them so that the blood flow leaving the penis is restricted. The penis enlarges and becomes rigid.

Muscular contractions, moving the sperm, increase also.

In a sexually aroused woman, the vulva becomes swollen because of increased blood supply, and the walls of the vagina secrete fluid (lubricant for entrance of penis). This lubrication is caused by contraction of muscles around the blood vessels in the wall of the vagina, forcing fluid out of the enlarged vessels.

When the penis is inserted into the vagina, stimulation by the movement of the genitals against each other may result in an

orgasm

- Increase in heart rate + blood pressure.
- Engorging of various tissues with blood.
- Faster and deeper breathing

Finally: an explosive burst of involuntary muscular contractions.

In men: accompanied by ejaculation (forceful ejection of semen) propelled by peristaltic waves of contraction of the muscles in the sperm ducts.

In women: rhythmic spasms of the muscles surrounding the vagina.

No orgasm is needed for fertilisation to occur. Often a small amount of semen is released before ejaculation, and this may contain enough sperm to fertilise an ovum !!!!

D. THE MENSTRUAL CYCLE.

At puberty (10-14 years of age), the pituitary gland (forehead) starts a series of hormonal cycles that periodically render a woman fertile (= capable of becoming pregnant) until the cycles cease at the menopause (30-40 years later).

Hormonal changes + effects they produce = MENSTRUAL CYCLES.

Human menstrual cycles are very variable but the "model" cycle lasts 28 days. The days are numbered from the first day of the menstrual period.

- The pituitary gland secretes more and more **F.S.H.** which causes an ovarian follicle to mature and produce the hormone **oestrogen**.
- A surge of oestrogen from the follicle stimulates an increase in secretion of **Luteinizing hormone (L.H.)** by the pituitary gland.

Created by Bernard Brochez

- L.H. + F.S.H. bring about the final maturation of the follicle, culminating in ovulation. The follicle ruptures and releases a mature ovum.

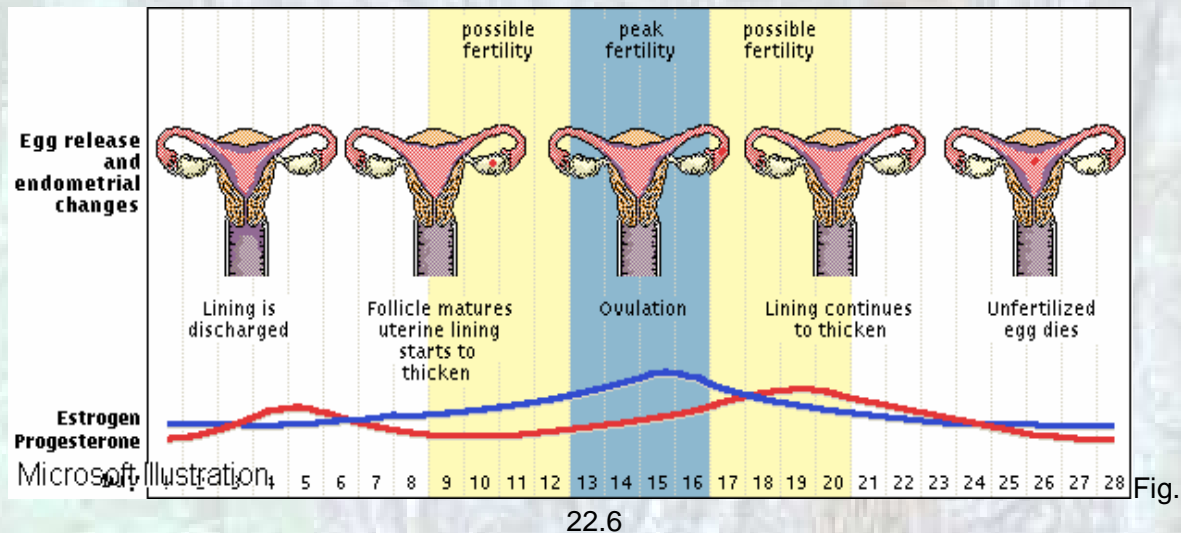

- Ovulation = approx. Day 14 of the model cycle.
 - **If you are a female student: In YOUR cycle, ovulation is 14 days before your next periods. For example: YOUR bleedings are thirty days apart: YOUR ovulation is on day 16 of YOUR menstrual cycle!!!!!!!!!!**
- Under influence of L.H., the cells of the ruptured follicle grow and form a **CORPUS LUTEUM**, which secretes more oestrogen and another hormone **progesterone**. It then degenerates.
- Progesterone + oestrogen stimulate the **endometrium** (lining of the uterus) to thicken and to secrete nourishing fluid, in preparation to receive the fertilised ovum.

If there is no fertilisation, the levels of hormones drop, the corpus luteum degenerates and the endometrium dies and goes out as menstrual fluid.

Proliferative phase: uterine wall thickens ----> developing long narrow glands and rich blood supply.

Secretory phase: endometrium continues thickening, glands become wide and twisted, secreting a glycogen-rich nutritive material.

- Some women are bad-tempered just before menstrual period starts. Probably as a result of the high levels of progesterone and oestrogen in the blood.
- Others experience pains (cramps) during menstrual periods and, occasionally, at time of ovulation.
- Menstrual cramps are thought to be due to the accumulation of local lipid hormones. Prostaglandines = a group of +/- 20 fatty acid derivates in the uterus.

Created by Bernard Brochez

The fertile phase in the cycle is when ovulation has occurred.

Meaning: intercourse between day 10-11-----15-16 may result in fertilisation.

Infertile periods are just after or just before menstruation fluid is expelled.

The menstrual cycle is variable in length! Emotional state (worries, problems) and diet of a woman also play an important role!!!!

E. FERTILISATION AND IMPLANTATION

- Sperm released into the vagina during ejaculation, swim through the cervix and uterus into the oviduct, where fertilisation usually occurs.
- An ovum can be fertilised +/- 36 h. after being released during ovulation.
- A sperm can fertilise the ovum: +/- 2 days after ejaculation.

When a sperm penetrates the ovum membrane, a rapid electrical reaction, followed by a slower chemical change, runs through the membrane. After this, the ovum cannot be penetrated anymore by another sperm.

Fig. 22.7

The fertilised ovum moves slowly down into the uterus; it is already a MORULA undergoing the cell divisions of cleavage. About a week after fertilisation, the embryo starts to implant in the endometrium of the uterus. An intimate anatomical and physical link between mother and embryo is established. Between fertilisation and implantation the embryo is free-living.

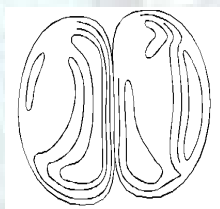
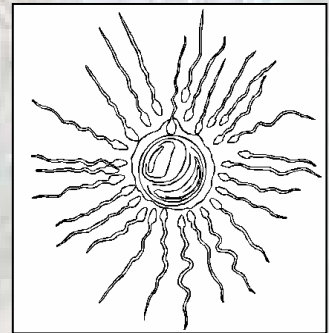

first cleavage

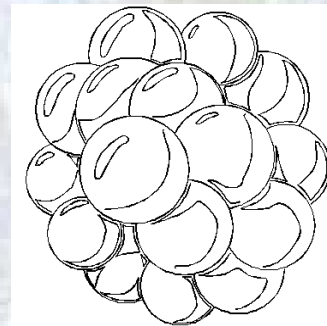

morula

Fig. 22. 8

When the morula reaches the wall of the uterus, it consists of a little ball of cells which develop into the embryo and a sphere of cells surrounding the future embryo. Some of these outer cells invade the wall of the uterus (to anchor the embryo) and it develops into the most important organ of pregnancy: the **placenta**.

Created by Bernard Brochez

Other cells in this outer sphere give rise to:

- amnion
 - chorion
 - allantois
- } 3 extra embryonic membranes

At first the placenta is tiny, but at birth (9 months later) it will be an organ looking like a raw hamburger (the size of +/- 4 dinner plates.)

The membranes joining the embryo to the placenta develop into a cord, the **Umbilicus**, which grows thicker and longer.

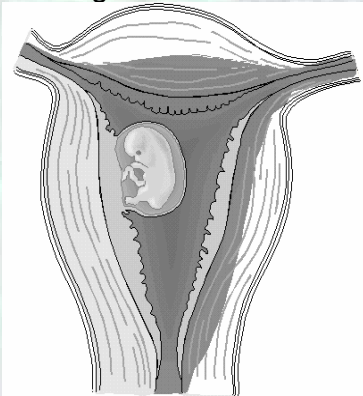

Fig. 22.9

Through this cord blood from the foetus goes to the placenta and back. In the placenta, blood capillaries of mother and foetus lie intermingled and maternal and foetal bloodstreams exchange substances by way of the surrounding extracellular fluid. Foetal blood picks up oxygen and food, and gives off wastes. Other substances like nicotine and alcohol can pass!!!!

The **amnion** is a fluid-filled sac around the embryo cushioning it against bumps. This sac bursts when “the waters break” during birth. The amniotic fluid contains cells sloughed from the embryo.

Amniocentesis = drawing fluid from the womb by a doctor to check for chromosomal defects in the embryo.

Allantois = a sac connected to the embryo's gut.

In reptiles and birds it stores embryo's wastes.

In humans it makes up most of the embryonic side of the placenta.

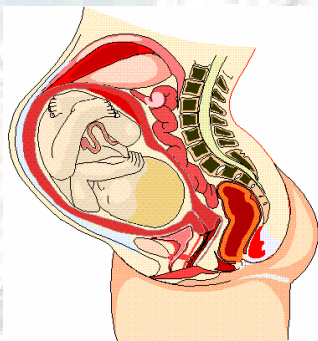

Chorion (third membrane) surrounds the foetus outside the amnion. It is also a part of the placenta. It secretes a progesterone-like hormone that maintains pregnancy.

Fig. 22.10

Created by Bernard Brochez

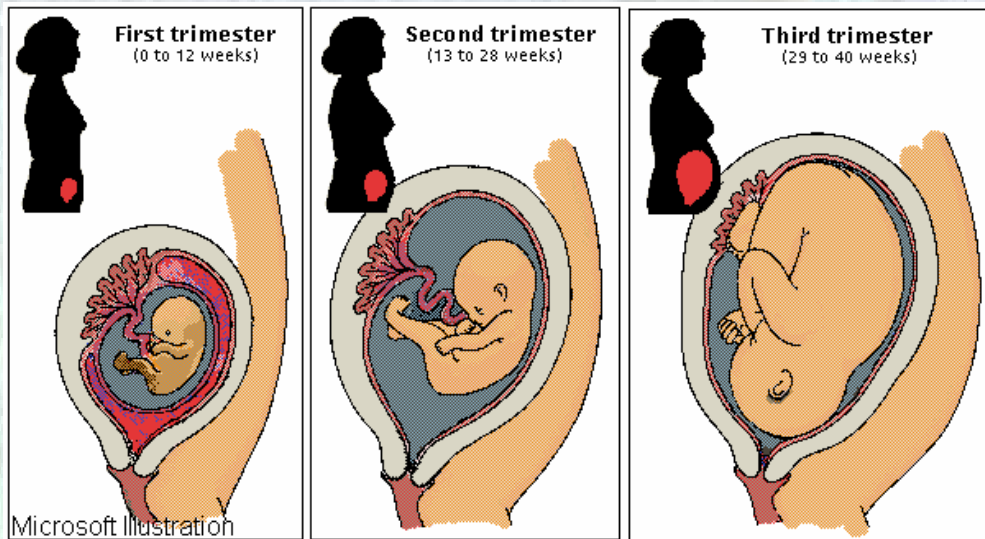

Fig. 22.11

F. BIRTH.

In humans, birth is approx. 270 days after conception.

Some time before giving birth the baby is going to make a turn in the womb, so as to put its head in front of the cervix.

The process in which uterine contractions expel the baby and placenta is called **LABOUR.**

There are three main stages:

- **Dilation:** (2-20 hours). It ends with the cervix being fully open or dilated.
- **Expulsion:** (2-100 minutes) begins with full crowning = appearance of the baby's head in the cervix. The baby is being born
- **Placental stage:** begins when the baby is born. The uterus continues contracting and 5-45 minutes after birth the placenta is expelled. Umbilical cord can now be severed and the baby starts its independent life.

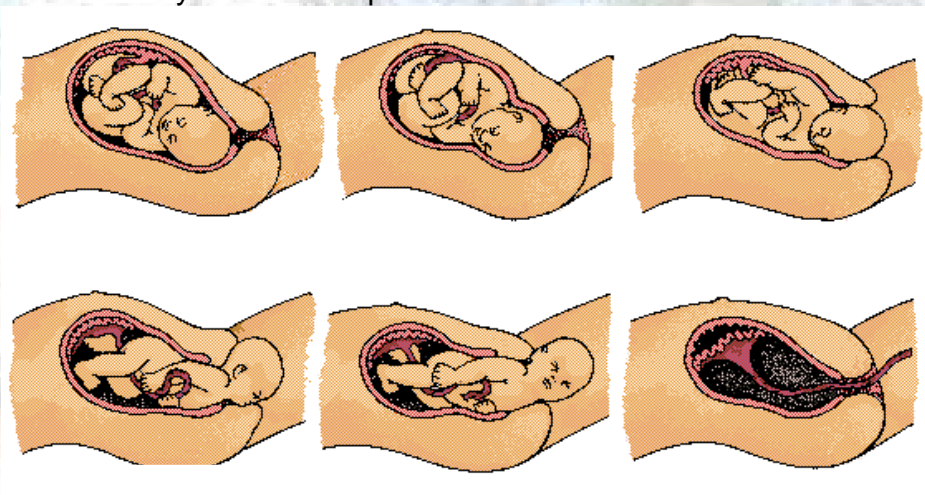

Fig.22.12

Created by Bernard Brochez

G. DIET DURING PREGNANCY.

A pregnant woman who has an adequate diet needs to take in no extra food. Her body's metabolism will adapt to the demands of the growing baby. If her diet however is deficient in protein, calcium, iron or Vit. D, she needs to increase her intake of these substances.

The physician will indicate a diet based on the essential four food groups (carbohydrates, fats, proteins, water soluble vitamins.)

The woman eats those foods with large amounts of calcium, phosphorous, iron, protein and vitamins which are recommended by her doctor.

The biggest problem is keeping the weight gain within the physician's allowance. Too much weight can cause discomfort. An extra 10 kg. however is not unusual.

H. BREASTMILK compared to BOTTLE MILK

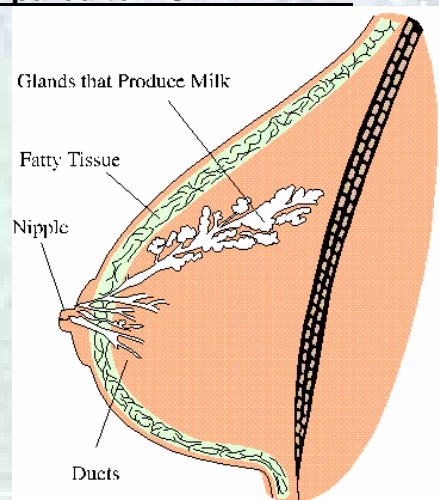

Fig 22.13

Breastmilk is made by the mammary glands. Once this has occurred, milk production is on a supply-and-demand basis. The baby's suckling is a stimulus for secretion of more **prolactin, a hormone that induces the mammary glands.**

The breastmilk contains all the food, vitamins and salts required by the baby. No iron is present in the milk. Haemoglobin isn't manufactured. Fe is stored in the body of the foetus during gestation.

Easy: You always have the right amount, the right T°...

Breastmilk

- Cheap
- Contains antibodies
- Never indigestion (+/-)
- Less overweight for the baby
- Bond of affection
- uterus returns to normal faster
- periods stay out longer

Bottlemilk

- more expensive
- no antibodies
- baby puts on weight
- easier
- mum can go out (work)

I. BIRTH CONTROL AND FAMILY PLANNING.

Family planning is one of the most discussed topics nowadays. Ecologists fear that with an increase of the world population as it is now, there will be too many people for the Earth's resources to keep up with the demands. In simple words: In thirty years there won't be enough food for all the people.

Therefore the W.A.O. urges people to do family planning. There shouldn't be more than 3 children per couple.

Contraception refers to birth control methods that prevent fertilisation. Methods which are a 100 % reliable are **abstention and sterilisation**. Another very reliable way is taking birth control pills.

I-1. MEANS AT OUR DISPOSAL.

I-1.1. Devices:

- **The pill** (hormonal): it contains synthetic oestrogen and progesterone. A woman takes the pill for 3 weeks and then stops for 1 week. The resulting decrease in hormone level causes menstruation. The given dosage of hormones prevents ovulation.
- **Rubber diaphragm**, which is smeared with a **spermicidal jelly** or cream each time it is used. The woman inserts it into the vagina so that it covers the cervix. Sperms cannot reach the egg. The diaphragm should be the right size, so consult a doctor.
 - **New device**: foam sponge, impregnated with spermicide === one size fits all.
- **Condom** (used by men) is rolled onto the erect penis shortly before intercourse. It catches the semen, so no sperms enter the vagina. The woman can use spermicidal foam inserted into the vagina. A combination of the two gives you a 100% reliable method.
 - Advantage of a condom: it reduces or prevents the spread of STD's.
- **Rhythm method**: = avoiding intercourse during the woman's fertile period. Not reliable at all, since ovulation can occur at any time during the menstrual cycle.
- **Mucus method**: Around ovulation time, there is a different discharge from the vagina. By feeling that mucus between your fingers, you can know if you are fertile.
- **Coitus interruptus**. The man withdraws his penis just before ejaculation. Unsafe, since a little semen is lost before ejaculation. It can contain enough sperms to fertilise.
- **Intra-uterine devices (IUD's)**: small plastic or metal objects inserted into the uterus by a doctor.

Created by Bernard Brochez

- Are not really contraceptives: they somehow act on the uterine lining so that the already developing embryo cannot implant.
- Disadvantage: they can become deeply imbedded in the uterus wall, and can cause abdominal infections. They then need to be surgically removed, and a possible infertility can result.

I-1.2. Sterilisation. = +/- a permanent change.

- **Man: Vasectomy**: severing and tying of the vasa deferentia. Sperms are still produced but are reabsorbed in the body. The fluid ejaculated is secretions of various glands. The volume is little less than with sperm.
 - **Future**: valve in sperm duct which can be turned open or closed.
 - **Sperm banks**: before a man decides to undergo a vasectomy, he can freeze in and store some of his sperm.
- **Woman: Tubal ligation**: = cutting and tying off of the fallopian tubes.

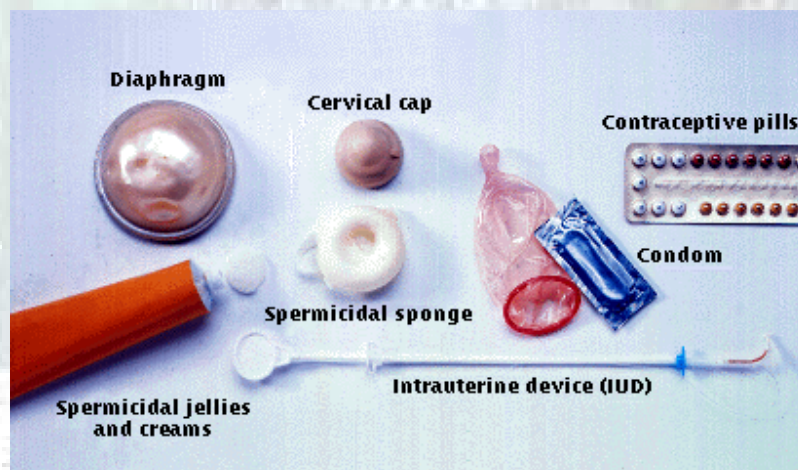

Fig. 22.14

I-1.3. Abortion: it is probably the oldest human birth control method known.

23. SEXUALLY TRANSMITTED DISEASES. (STD's)

A. GONORRHOEA.



Caused by *Neisseria gonorrhoea* (gonococci), which are spread by sexual intercourse. Pus discharges of the infected reproductive organs contain the gonococci.

Fig. 23.1

If not treated, the gonococci work their way along the passages of the reproductive organs. The gonococci may destroy the delicate structures of the male testicles. In females, they travel into the uterus.

Signs

- 2-9 days after exposure: man has burning pain during urination + discharge of pus. ---> if so: immediate medical treatment is necessary.
- No early signs of infection in women. However, months after exposure (gonococci have passed into uterus) the infected woman will have pain in the lower abdomen and a vaginal discharge. (Samples of secretions from cervix, vagina and urethra tell if gonococci are present)
- Blood tests do not reveal the presence of the disease. All gonococci should be destroyed before any further sexual activity. No immunity is acquired, so you can get infected many times.
- If untreated: sterility can occur (both in male and female) Gonococci can attack the joints upon which you develop gonorrhoeal arthritis.
- In a mother to be: gonococci can infect the baby's eyeballs at birth.

Treatment.

Antibiotics are very effective. If started soon enough, complete treatment is achieved within several days.

After treatment: stay under a physician's care.

Created by Bernard Brochez

B. SYPHILIS.

- caused by *Treponema pallidum*, spread by sexual inter-course or kissing an infected person with sores on her/his lips.

Once Treponema is outside the human body, it is killed in seconds, so toilet-seats, doorknobs ...are safe.

- There are four stages: primary, secondary, latent, late.

Once the spirochetes are beneath the surface of the skin or mucous membrane, they enter the lymph channels and go to the nearest lymph gland to multiply and grow. Later on, they go to the circulatory system by which they get spread throughout the body. They burrow deep into the bone marrow.

a) primary syph.: destruction of tissues, bones and organs

Some three weeks after entering the body a **CHANCRE** (sore) appears at the place of entry. This is mostly on or near the genital organs but it can also be on lips, breast, or hidden deep inside the body. This sore lasts about 4-6 weeks.

(Chancre = open sore or blister or pimple, but usually it is a round ulcerous lump with sharp raised edges.)

Fig. 23.2

After some time it disappears, but this is not a sign that you are cured!!!!



b) secondary syph.: 6 weeks - 1 year. Signs of syphilis appear:

There may be fever, swollen lymph glands, white sores in mouth and about genital organs, sore throat...

Huge patches of hair come out with combing, and skin may become dry and scaly. **SIGNS CAN BE MILD AND OVERLOOKED !!!!**

This stage is the most infectious one!!!!!!

After some time, the signs vanish and the disease lies hidden again.



c) latent syph.: 1-40 years.

The spirochetes are digging into deep tissues of the body. A blood test will reveal their presence.

d) Late syph.: This stage occurs with little or no warning. Spirochetes attack C.N.S., and optic nerve + brain tissue may be destroyed. Infection occurs in spinal cord. Erosion of reasoning centre of brain. They can also invade walls of heart causing inflammation.

Fig. 23.3

Created by Bernard Brochez

e) congenital syph.: (existing at or from birth) NOT INHERITED!!

Mother----- syphilis goes through the placenta to the baby. Baby may be blind, deformed, or dead at birth. If it is alive it may be cured, but some tissues may be lost forever.

If infected with Treponema: the human's defence system produces a complex antibody response which can be detected by blood-tests

Treatment

If discovered as the primary type, it can be cured in a short time. The objective is to maintain a desired level of antibiotics in the blood for a long enough time to kill the spirochetes.

The sooner it is treated, the more chance of killing Treponema.

C. HIV - VIRUS ~ AIDS

HIV = Human immuno-deficiency virus

AIDS = Acquired immune deficiency syndrome

If infected, the body makes antibodies which cannot kill the virus. The virus is slowly destroying our immune system. So you get sick from other diseases.

First discovered with homosexual men who suffered from a certain type of pneumonia. Also a special type of skin cancer (Kaposi's sarcoma) was seen, which usually was frequent in older persons.

Kaposi's sarcoma = brownish, bluish spot (like a bruise)



© 1994 Jeffrey L. Melton, M.D.

Fig. 23.4

How do you get AIDS?

- unsafe sex
- exchanging contaminated syringes (drugs)
- pregnancy: mother to baby
- unsafe blood transfusion

Fig. 23.5



Fig. 23.5: antiAIDS_5

Created by Bernard Brochez

Blood, sperm or vaginal fluid are the main carriers of the virus. Other body fluids contain them also, but the concentration is too low!! So, saliva, sweat, mother-milk, tears, urine are NOT dangerous!!!

You can't get aids by:

- Kissing
- Toilet seats
- Social contact with an AIDS patient
- Contact with body fluids (except if blood is present)
- giving First Aid (be hygienic)
- Animals
- Food

AIDS test

The body makes antibodies which can be detected by blood tests. Is performed mostly to ensure safe transfusions. The disadvantage is that it is only possible after three months of infection.

To be HIV-seropositive

It means that by blood-tests it is seen that you have antibodies against the virus present in your blood. You are not sick yet!!

Signs of the disease.

Extreme fatigue, sweating, fever, loss of weight, swollen lymph glands, severe diarrhoea, coughing, shortage of breath...

The diagnosis "You have AIDS "is stated only if you have a severe infection of lungs, intestine, brain or a certain form of cancer.

TREATMENT

Is very difficult!!!!

AZT (zidovudine): this drug stops the multiplication of the virus

Methods to control the spread

- Stick to one faithful partner
- Use a condom if you have sex and you are not certain about your partner.

24. GENETICS - INHERITANCE

A. Variation.

Individuals of a species of plants or animals are alike in all major respects. E.g. Mice are recognisable as mice although, the different individuals are different in coat colour, the size of the ears...

A-1. Discontinuous variation.

e.g. Coat colour, there are no intermediates:

Black male mouse X brown female mouse

The offspring is either black or brown.

====> There is no continuous series of colours ranging from black to brown with almost imperceptible differences of colours between 2 adjacent members of the series.

e.g. Inheritance of sex: you are either a boy or a girl, there are no intermediates (except for a few abnormalities).

e.g. Inheritance of bloodgroups: A, B, AB, O.

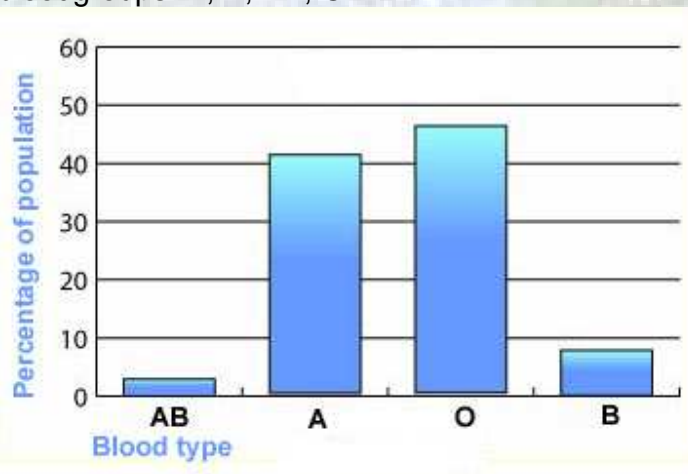

Fig. 24.1

The features of discontinuous variation are genetically determined. They are not altered during life time. (Eye colour is a constant feature).

A-2. Continuous variation.

e.g. height or weight of persons.

The classes in which you put the individuals become more arbitrary. There are tall people and short people, but there are also plenty intermediates. The features are also genetically controlled, but they are likely to be under the control of several genes.

e.g. Tall people: 20 genes } Hypothetical!!!!
Short people: 5 genes }

Here, there is also an influence of the environment. E.g. a person who should (according to his/her genes) grow tall is deprived of food when he/she was still a child. The growth of the person will be less.

B. Some definitions

- Nucleic acids (= acids of the nucleus) are the largest molecules made by organisms. There are two kinds of nucleic acids:

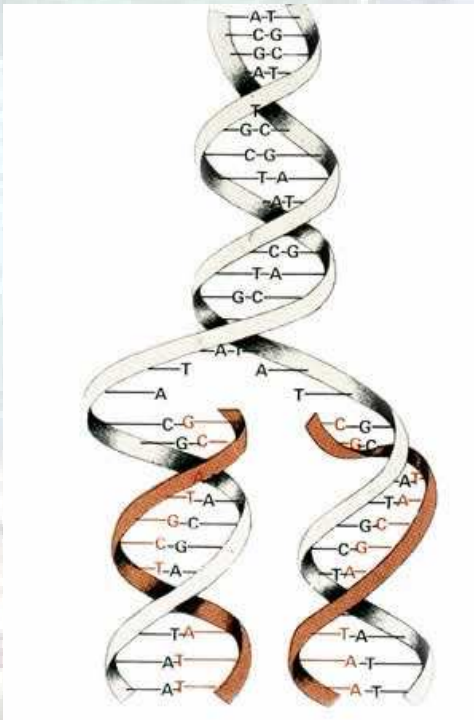

- **D.N.A.:** DeoxyriboNucleic Acid. The genetic material, it contains the organism's genetic information, including instructions for the sequence of A.A. in polypeptides. It dictates the structure of proteins.

Fig. 24. 2 DNA

- **R.N.A.:** RiboNucleic Acid. The information to make this N.A. is also carried on the DNA. RNA participates in the synthesis of polypeptides.

Fig. 24.3 RNA

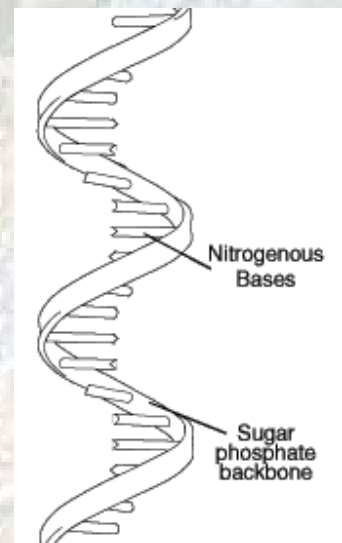

Created by Bernard Brochez

- **Chromosomes:** The genetic material (DNA) in the nucleus of a eukaryotic cell is organised into chromosomes. Each chromosome consists of a long strand of DNA, and associated RNA and proteins. The chromosomes coil up into short thread-like structures just before and during division of the nucleus, which precedes cell division.

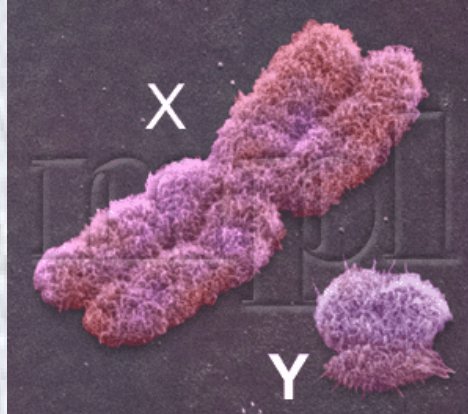

Fig. 24.4

- **Chromatin:** When the nucleus is not dividing, the chromosomes uncoil in a loose, indistinct tangle called chromatin.
- **Gene:** The unit of genetic information. It governs inherited characteristics such as hair colour, skin colour. For each characteristic there is a gene, even for each protein made in our body. Genes are carried on the chromosomes.
- **Allele:** Portion of DNA that carries the information for contrasting forms of the same genetic trait (e.g. blue eyes and brown eyes).

C. Nuclear divisions.

The most complicated part of cell division is nuclear division; here the problem is to divide the replicated chromosomes accurately into two complete sets. The 2 main types of nuclear divisions are MITOSIS and MEIOSIS.

1. MITOSIS: produces daughter nuclei with the same number of chromosomes as in the original nucleus.

2. MEIOSIS: produces daughter nuclei with only half the original number of chromosomes but with new genetic combinations.

Shortly after nuclear division, the entire cell will divide into 2 new daughter cells. Meiosis and mitosis only occur in eukaryotic cells.

A zygote (sperm + egg) develops into an embryo and eventually into an adult organism by repeated mitotic cell divisions, accompanied by cell differentiation to form specialised tissues (brain, intestines, skin, eyes....) and by growth of the organism as a whole.

Created by Bernard Brochez

C-1. CELL CYCLE

A complete life cycle of a cell consists of:

MITOSIS and
INTERPHASE: G₁, S, G₂ phase.

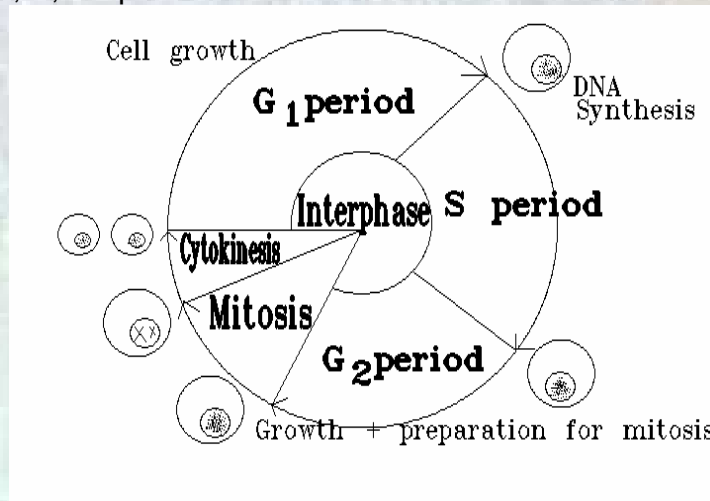

Fig. 24.5

C-2. MITOSIS.

= the series of events in which a cell's chromosomes, already replicated during the S period, are separated into two equal groups.

During interphase, between mitoses, the chromatin is spread out in a loose mass, and the individual chromosomes are indistinguishable. The chromosomes are replicated during the S phase.

Mitosis is continuous, but for convenience it is divided into 4 stages according to the appearance of the chromosomes as viewed through a microscope: prophase, metaphase, anaphase, telophase.

INTERPHASE

- Chromatin is spread out in an indistinct mass.
- Nucleus and nucleolus are distinct.

PROPHASE:

- Chromatin condenses into distinct chromosomes (sister chromatids)
- Nucleolus (site of ribosome synthesis) disappears.
- Nuclear envelope disappears.
- Mitotic spindle (framework of microtubules) will be formed. This will be involved in the movement of the chromosomes.

Created by Bernard Brochez

METAPHASE:

- Mitotic spindle is complete
- Chromatid sets move to the spindle equator

ANAPHASE:

- Kinetochores divide, freeing the sister chromatids as individual chromosomes
- Chromosomes move to opposite poles of the spindle.

TELOPHASE:

- 2 new nuclei form
- Division of cytoplasm often begins now
- New nuclear envelopes are being formed.

CYTOKINESIS = CELL DIVISION:

Microfilaments constrict the cell at the spindle equator, pinching the cell in two.

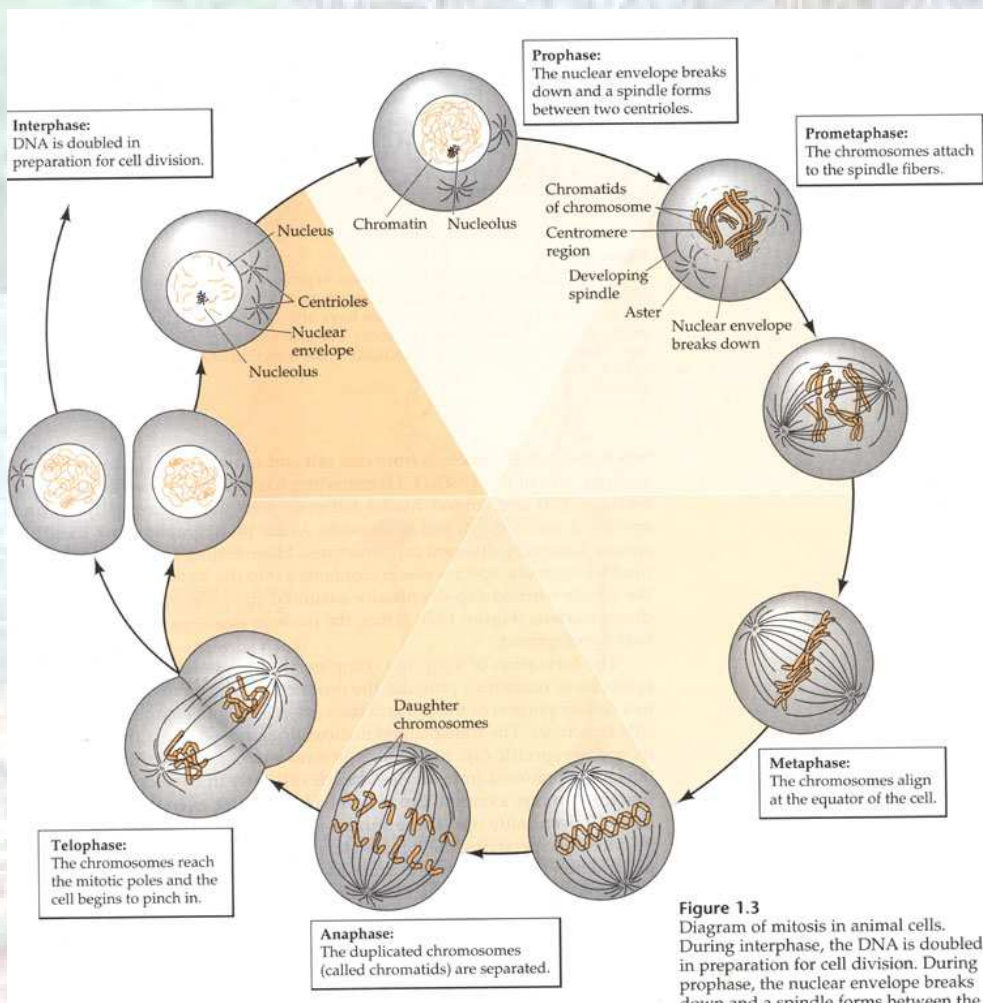

Fig. 24.6

C-3. MEIOSIS:

- **MEIOSIS I:** Homologous chromosomes separate from their partners.

PROPHASE I:

- Replicated chromosomes pair with their homologues to form TETRADS.
- Pairing is necessary for separation of members of each homologous pair in the first meiotic division ==> each resulting nucleus receives one member of each pair. (Crossing over happens now.)

METAPHASE I:

- Tetrads move to equator.
- Nuclear envelope disappears.

ANAPHASE I:

- Each set of sister chromatids moves towards the pole, as its homologue travels to the opposite pole.
- Sister chromatids travel as pairs!!!! They separate at anaphase II

TELOPHASE I:

- Chromosomes have formed 2 groups.

• **MEIOSIS II**

Each nucleus divides again, producing haploid nuclei. Sister chromatids become separate chromosomes.

PROPHASE II

METAPHASE II

- Spindle forms again, chromatids move to the equator.
- Centromeres divide ==> Chromatids become separate chromosomes.

ANAPHASE II

- The separated chromosomes move to opposite poles of the spindle.

TELOPHASE II

- Four haploid nuclei are formed, each with one member of each pair of chromosomes from the original nucleus that entered meiosis.
- Nuclear envelopes form.

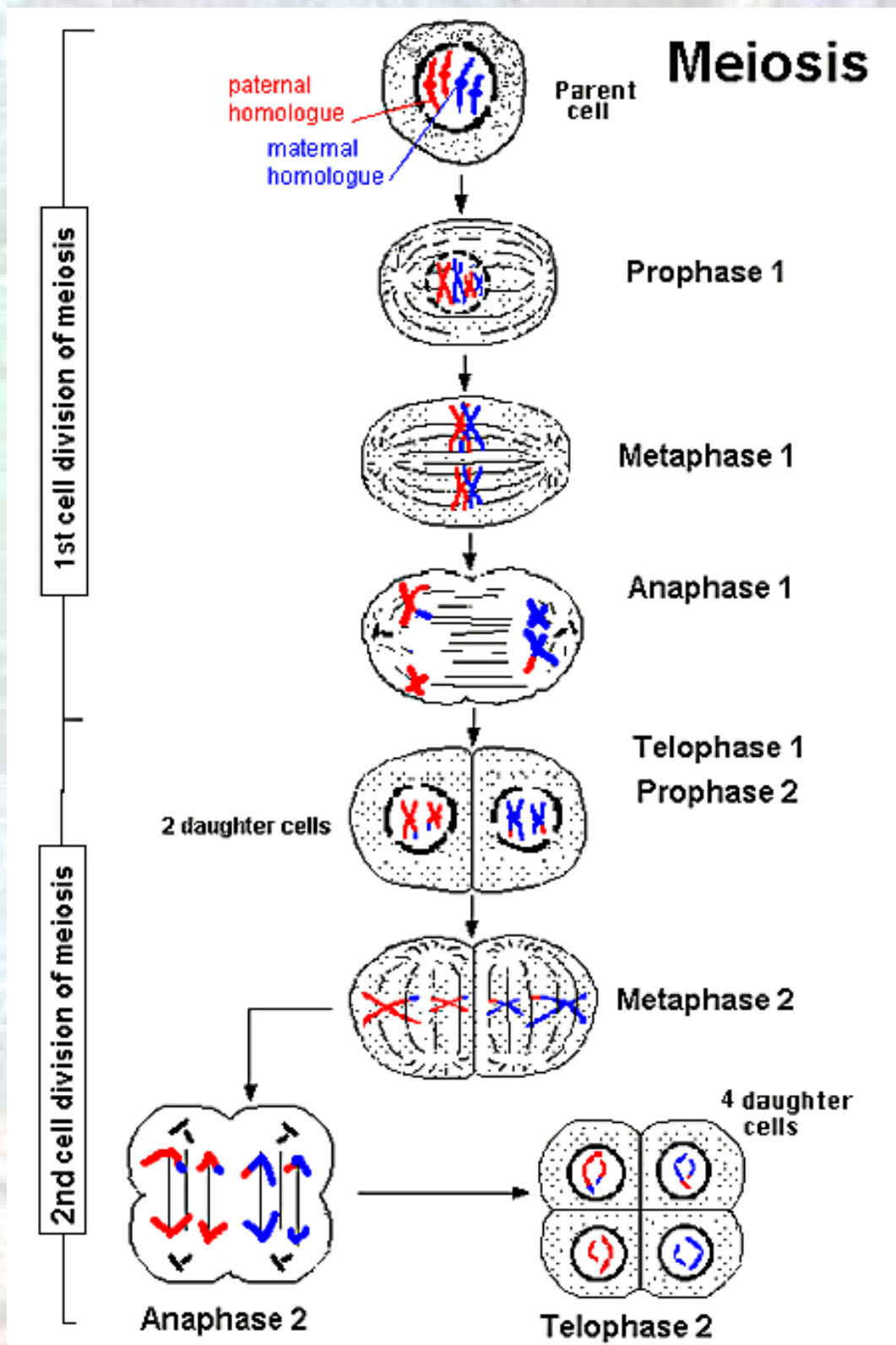

Fig. 24.7

Created by Bernard Brochez

CROSSING-OVER

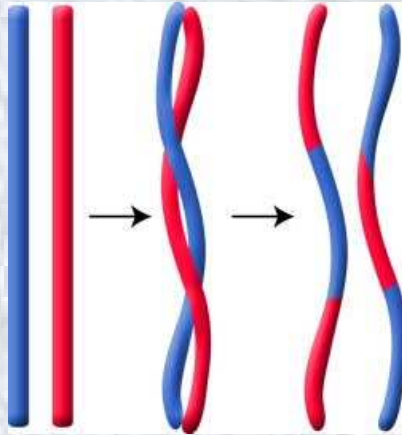

Fig. 24.8

Chromatids may form chiasmata (areas of crossing over), break off, and rejoin onto another chromatid====> This produces 4 chromosomes with different gene combinations.

In the example above, we just considered one chromosome pair you've received from your parents. It is obvious that you and your partner can have millions of different children since you have 23 chromosome pairs from your parents and so does your partner!!!

D. MENDELIAN GENETICS.



The laws of heredity were discovered by Gregor Mendel (opposite) in about 1856 - 1863. Mendel conducted experiments in plant hybridization, collecting the results of cross-fertilizing hundreds of edible pea plants.

The results from Mendel's experiments confirmed his ideas about heredity: the law of segregation, which has become known as Mendel's First Law, and the law of independent assortment, also known as Mendel's Second Law.

Fig. 24.9

Gregor Mendel did research on peas, which have an unusual flower structure. Peas have a modified petal which surrounds the reproductive parts. So it is very easy to control their breeding.



Created by Bernard Brochez

He started off by performing crosses involving only one trait, e.g. Height.



Pure breeding TALL plants. X pure breeding SHORT plants.

He opened the flowers and removed the stamen. Then, he hand-pollinated both flowers with pollen from the other plant.

This will produce **HYBRIDS** = offspring between genetically unlike strains of organisms.

He collected the seeds and planted them. After some time, when the plants started to mature, all the plants were TALL.

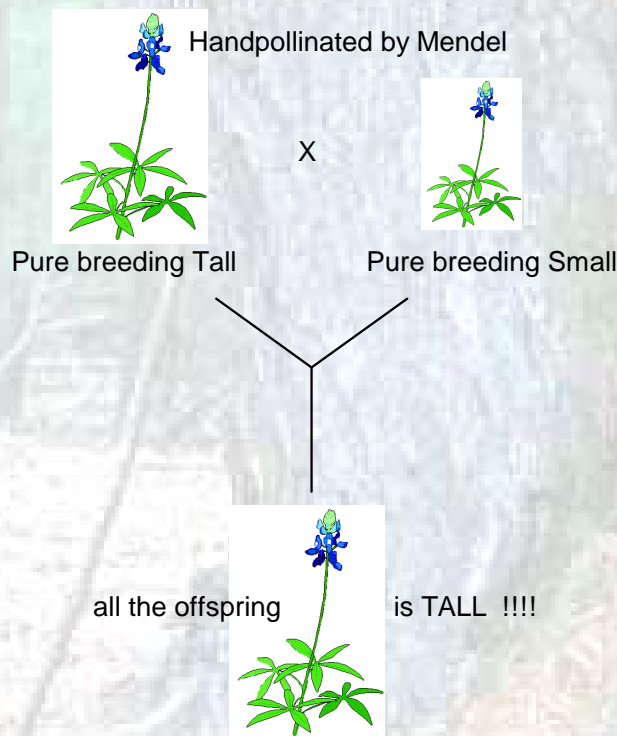
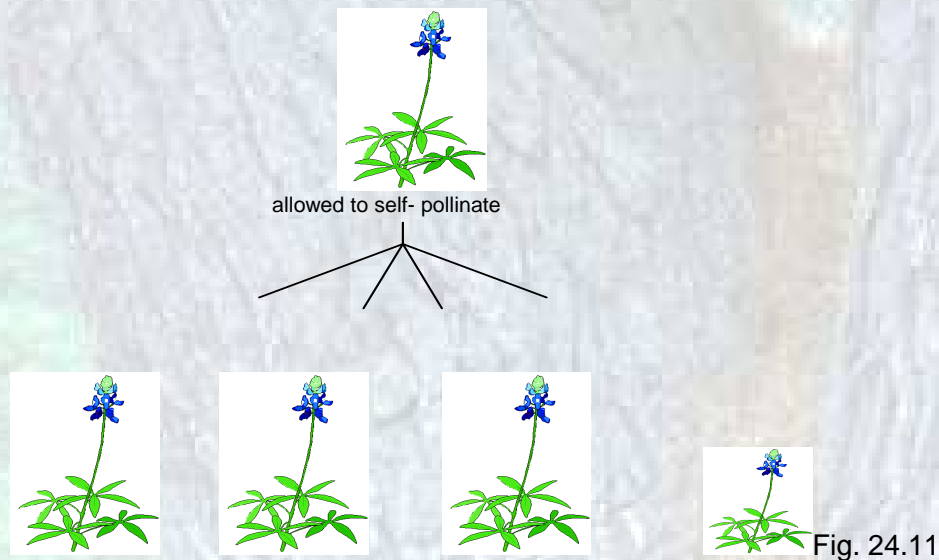

Fig. 24.10

These same plants now were allowed to self pollinate. From the 900 seeds, Mendel collected and planted, most grew into Tall plants. About 1/4 grew into Short plants.



So, he concluded:

An inherited trait (height) is governed by two factors (now called genes).



a plant received 2 genes for each of its traits, one from each parent.

Each plant passed on one of its genes at random to each offspring plant.

Diploid eukaryotic cells contain pairs of homologous chromosomes (usually of the same length).

Since a genetic trait can occur in 2 or more different forms (e.g. Tall - short plants), therefore, the genes that govern the trait must come in alternative forms: **ALLELES**.

A pea plant may have 2 alleles for Tallness, or 2 alleles for shortness, or it may contain 1 allele for Tall and 1 for short.

- A plant with 2 of the same alleles = **HOMOZYGOUS** for that allele.
- A plant with 2 different alleles = **HETEROZYGOUS** for that allele.

D-1. DOMINANT AND RECESSIVE ALLELES.

In his experiment, all of the F1 generation (first filial) were TALL plants. What had happened to the alleles for SHORT????

Since self-pollination of F1 gave TALL and SHORT plants, the allele for SHORT must have been carried in a hidden form.

Created by Bernard Brochez

Mendel concluded that in the heterozygous condition 1 allele of a gene may express itself (= appear as an observable trait in the organism) and mask the presence of the other allele.

- The allele that expresses itself = **DOMINANT ALLELE**.
- The allele that is masked = **RECESSIVE ALLELE**.

Homozygous and heterozygous red plants can not be told apart just by looking at them. The recessive allele can only be detected in homozygous condition.

- **GENOTYPE** = GENETIC MAKE-UP.
- **PHENOTYPE** = EXPRESSION OF ITS GENES (what you can see)

EXERCISES:

A plant with smooth seeds is crossed with a plant with wrinkled seeds. Both plants are homozygous, and the smooth seed shape is dominant over the wrinkled seed shape. What will be the offspring's genotype and phenotype?

Solution.

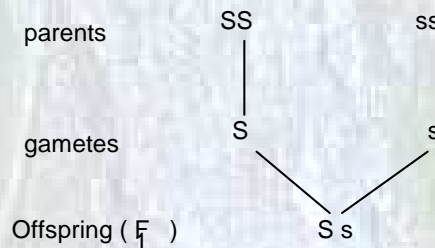

This exercise is an example of COMPLETE DOMINANCE.

D-2. SOME SIMPLE CROSSES:

Ex 1. Red flowered plants are crossed with white flowered plants. Red is dominant over white. The red flowered plant however is heterozygous.

parents: T t X t t

gametes: T, t t

F1 (offspring): T t and t t

Red White

So: The ratio is 1:1 = Half will be Red, half will be white

Created by Bernard Brochez

Ex 2. Red flowered plants (heteroz.) X Red flowered plants (heteroz.)

parents: T t X T t
gametes: T, t T, t
offspring: Tt Tt Tt tt
 Red Red Red White

In this last exercise we have a 3:1 ratio.

This means that 75 % will be Red, while 25 % will be white.

- P1 generation = parents.
- F1 generation = first filial = children
- F2 generation = second filial = grandchildren.

The observed ratio's can differ from the expected ratio's (the ones you have predicted on paper)!!!!

- Perhaps not all the progeny (F1) come to a mature state (plants can get eaten).
- Perhaps growing conditions are bad (plants die).
- There is not enough progeny (e.g. in humans). There are a million possible children for a married couple to have!!!!

D-3. To predict the outcome of a cross.

You will have to use one of the two following methods.

D-3.1. Branching tree.

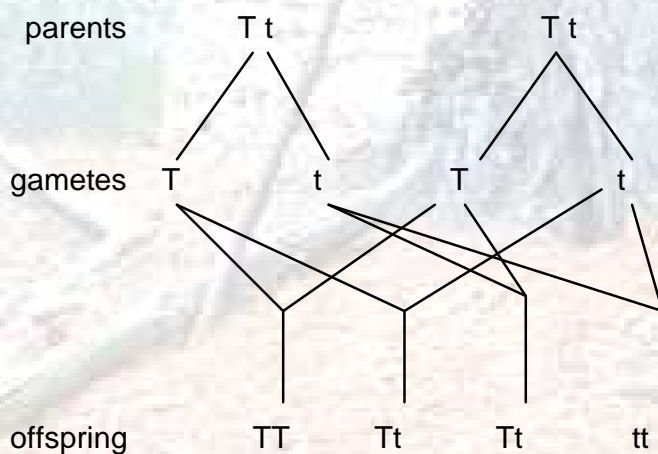

Created by Bernard Brochez

D-3.2. Draw a Punnett square: this is by far most the easiest way.

parents R r R r
 gametes R r R r

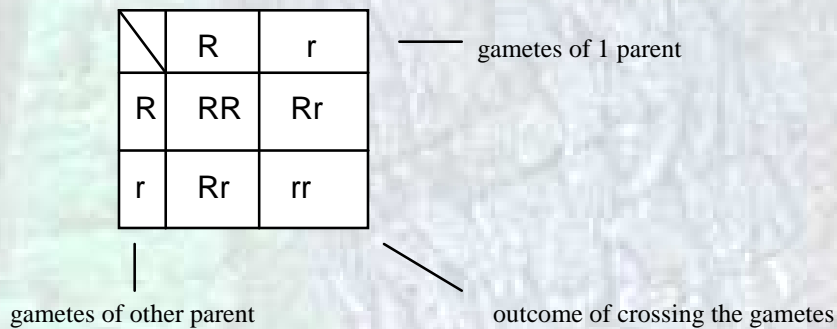

D-4. CODOMINANCE OR INCOMPLETE DOMINANCE.

E.g. In snapdragons, flower colour is controlled by alleles that show co dominance.

- Homozygous plants are either red or white
- Heterozygous plants are pink.

In this case, we can't use capital and small letters. We have to use Capital letters for both colours!!!!. But to indicate whether it is red or white, we will add something to the letter

(An asterisk or a dash).

RED X WHITE
 R R R'R'
 R R'
 PINK

We use R' instead of r since white is not recessive!!!!

If 2 F1 plants fertilise each other we get the following cross:

F1: RR' X RR'

gametes: R, R' R, R'

F2: RR RR' RR' R'R'

RED PINK WHITE
 1 : 2 : 1

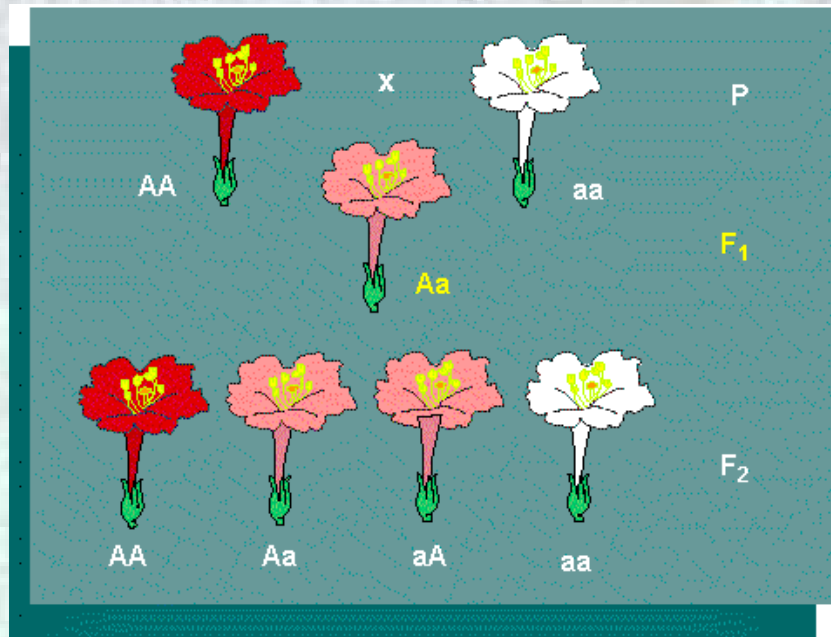

Fig. 24.12

D-5. CODOMINANCE AND BLOOD GROUPS.

There are 4 major groups of blood: A, B, AB and O!!!!, but blood group A and B show co-dominance.

The alleles for blood groups are represented by:
 I^A I^B I^O

- Blood group A: $I^A I^A$ or $I^A I^O$ = AA or AO
- Blood group B: $I^B I^B$ or $I^B I^O$ = BB or BO
- Blood group AB: $I^A I^B$ = AB Codominance
- Blood group O: $I^O I^O$ = OO homoz. recessive

EXERCISES:

1. Below is a pedigree of ABO blood groups for several generations of humans. Circles represent females, squares represent males. Horizontal lines represent marriages. Vertical lines represent their offspring (Brothers and/or sisters)

Give the possible genotypes for the persons marked with a letter (a, b, c, d, e, f, g)

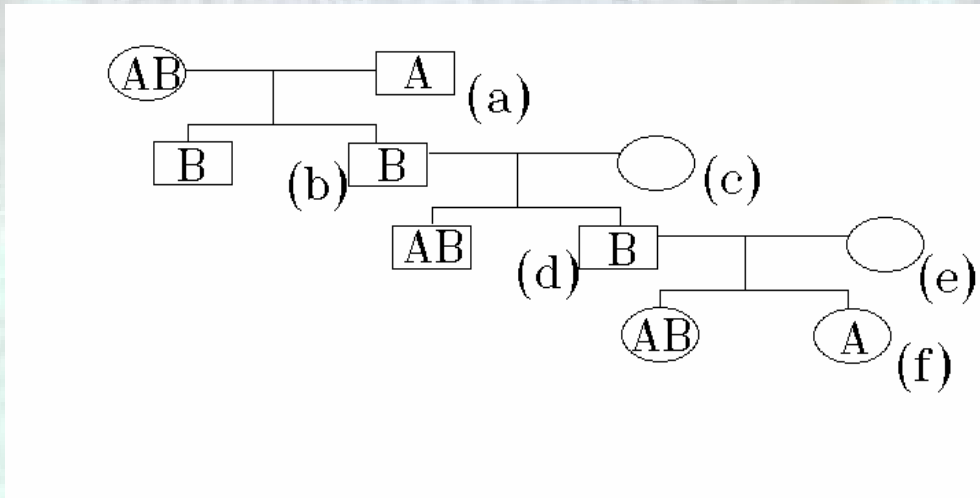

2. In rabbits, normal coat colour (C) is dominant to chinchilla (c^{ch}), which is dominant to Himalayan (c^h) which is dominant to albino (c). What offspring are expected from the following crosses and in what ratios?

- $Cc^h \times c^{ch}c^h$
- $c^{ch}c \times c^hc$
- $c^{ch}c \times c^{ch}c$

E. MUTATIONS.

Are inheritable changes in the genetic material. They may result from errors in replication, from damage that the DNA repair enzymes can't repair.

- Some mutations are:
 - Change of 1 nucleotide into another (point mutation)
 - Breakage of a chromosome.
 - loss of 1 or more chromosomes.
 - extra copy of 1 or more chromosomes.

Mutations are brought about by **mutagenic agents (mutagens)**. Various kinds of radiation cause mutations. X-rays and Radio-active particles may cause breaks in the DNA molecule. Certain chemicals also alter DNA molecules (nicotine, alcohol....)

Mutations are inherited when the non-corrected change is copied during replication and then passed on to a cell's descendants.

(of course this is only when the mutations are in the gametes or in the gamete-producing cells.)

Created by Bernard Brochez

Mutation in a body cell (somatic mutation) causes changes in the hereditary characteristics of the cell and of body parts made up of that cell's descendants.

Mutations in cells destined to form ova or sperm (germ cell mutations) can be passed on to an organism's offspring.

E-1. Sickle cell anaemia.

The most famous human allele that is frequently lethal in homozygous condition is the one that codes for the haemoglobin of sickle-cell anaemia.

Haemoglobin = oxygen-carrying protein in Red Blood Cells. It is made up of 4 polypeptide chains: 2 alpha and 2 beta chains.

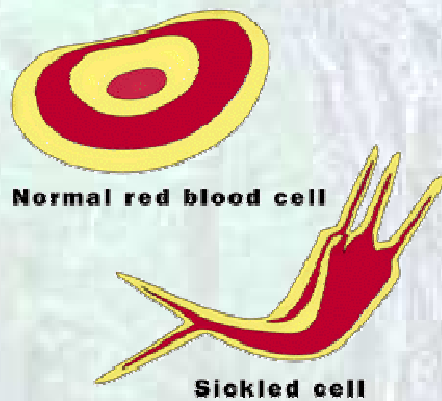

Fig. 24.13



Fig. 24.14

The sickle allele results from a point mutation (a change in just one nucleotide pair) in the normal beta chain allele. So only one Amino acid is changed for another in the haemoglobin's beta chain (valine instead of glutamic acid as its 6th A.A.)

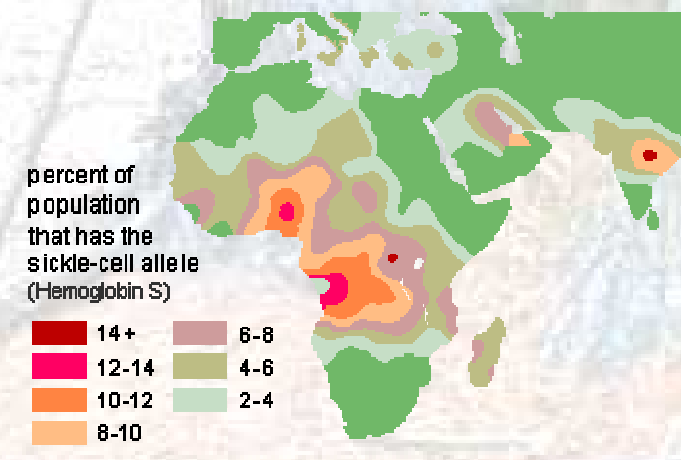

Fig. 24.15

Created by Bernard Brochez

This small change has drastic consequences. When R.B.C. with sickle haemoglobin are exposed to low oxygen levels, the haemoglobin molecules aggregate and form fibres. These fibres distort the cells into odd shapes (sickles). Sickled cells are more rigid and tend to become stuck in the capillaries. So the blood supply is stopped. In addition, sickled cells are fragile and break down easily, leaving the victim with fewer R.B.C. than normal.

This condition is known as anaemia.

Symptoms: since tissues are deprived of oxygen: tiredness, headaches, muscle cramps, poor growth and perhaps failure of heart and kidneys.

The sickle allele shows co dominance with the normal allele: heterozygous people have both normal and sickle Beta chains. Their R.B.C. sickle only when the oxygen level is extremely low (e.g. at very high altitudes).

In areas where malaria is frequently found, the sickle allele occurs at higher frequencies. The parasites die if the cell sickles. A full-blown case of malaria is avoided.

E-2. Down's syndrome.



Fig. 24.16

One of the best known chromosomal abnormalities. Not 46, but 47 chromosomes are found in persons suffering from Down's syndrome. These people have very low mentality, are short statured caused by retarded physical development, and have abnormalities of face, hands and feet, but seem always to be in a good mood.

These people have one extra chromosome, n° 21, which is found 3 times. This results from a non-disjunction of chromosome 21.

There are many physical characteristics that are associated with DS. Not every individual has all the characteristics; however, the following is a list of the most common traits:

- Low muscle tone
- Flat facial profile (depressed nasal bridge and small nose)
- Flattening of the back of the head
- Small hands and feet
- An upward slant of the eyes
- An abnormal shape of the ear
- A single deep crease across the center of the palm
- An excessive ability to extend the joints
- Fifth finger has one flexion furrow instead of two

Created by Bernard Brochez

- Small skin folds on the inner corner of the eyes
- Excessive space between large and second toe
- Enlargement of tongue in relation to the size of the mouth
- Mental retardation (can range from very mild to severe, however, is typically mild to moderate)
- Speech delays
- Short stature

In addition to the common characteristics, a child with DS may also have the following medical issues:

- Congenital heart defects
- Increased susceptibility to infection
- Respiratory problems
- Obstructed digestive tracts
- Hearing deficits
- Eye problems such as cataracts and strabismus
- Failure to thrive in infancy and obesity in adolescence
- Thyroid dysfunctions
- Skeletal problems (hip dislocations, atlantoaxial instability)
- Increased risk of developing Alzheimer's disease (over age 35) and leukemia

Abnormalities produced by non-disjunction of the sex chromosomes results in people having: XXY, XYY, XXX, X.

Some of these conditions produce sterility or mental retardation.

E-3. Haemophilia.

Certain forms of haemophilia are caused by a recessive allele located on the X-chromosome. A person with haemophilia produces very little of a protein needed for blood to clot and so may bleed to death after even a slight cut.

In case of a woman, she usually has a dominant normal allele on her other X chromosome, so she does not have haemophilia. A man, who has only one X chromosome, will develop the disease. A woman, in this case is said to be a **carrier** of the disease.

E-4. Red-Green colour blindness.

Also a recessive sex-linked trait (on the X-chrom.) in humans. C represents the normal allele, c = the recessive, mutant allele.

Parents	$X^C \quad X^c$	$X^C \quad Y$
gametes	X^C, X^c	X^C, Y
children	$X^C X^C \quad X^C Y$	$X^C X^c \quad X^c Y$

Created by Bernard Brochez

As a result, we get 2 daughters; both with normal vision, but one will be a carrier. One boy will have normal vision, and the other son will be R-G colour-blind.

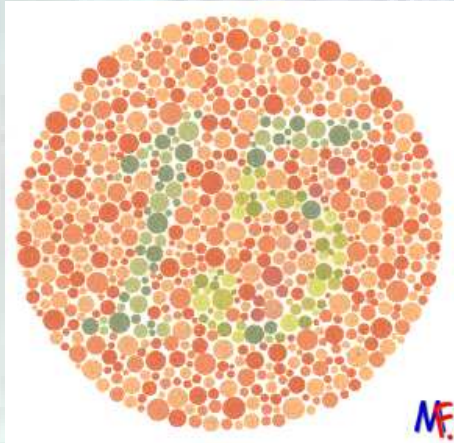

Fig. 24.17

Normal colour vision should read the number 15.
Red-Green deficiencies should read the number 17.
Total colour blindness should not be able to read any numeral.

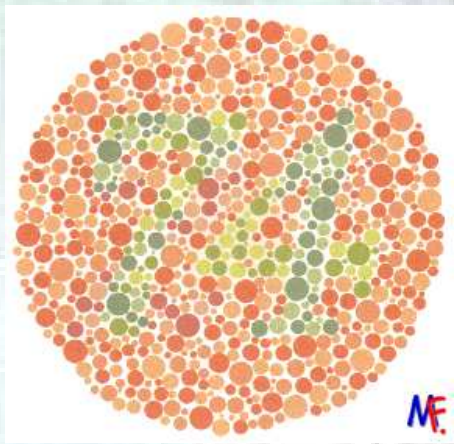

Fig. 24.18

Normal colour vision should read the number 74.
Red-Green colour deficiencies should read the number 21
Total colour blindness should not be able to read any numeral

25. SELECTION

A. Variation and competition

All individuals of a given species vary from one another.
E.g. humans: some are tall, others are short.

In animal and plant life, there is always competition between individuals of a certain species. Plants that grow taller than their fellow members of the same species will catch more sunlight and will therefore reproduce faster.

In a herd of zebra's, the strongest stallion will mate with the females.

As a consequence, the competition will lead to the survival and reproduction of those organisms best fitted to the environment.

A-1. Natural selection

It is the non-random differential survival and reproduction of genotypes from one generation to the next.

Individuals in every population show a range of phenotypes. When a selective force, such as predation or competition, is at work, some of these phenotypes are more likely to survive and reproduce than others.

If the phenotypic characteristics selected for, are at least partly under genetic control (as they usually are), then the genes responsible for the favoured phenotypes will be represented at higher frequencies in the next generation.

Natural selection is by far the most important and potent evolutionary force.



Natural selection does not grant organisms what they "need".

Fig. 25.1

Created by Bernard Brochez

Two common forms of natural selection are:

- **STABILISING SELECTION**: in which average phenotypes have a selective advantage over extremes in either direction.
- **DIRECTIONAL SELECTION**: in which the phenotypes at one extreme have a selective advantage over those at the other.

E.g. a population of seeds.

If seeds of average size have a better chance of germinating and of growing than seeds that are unusually large or small, the next generation will contain a lower proportion of unusually large or small seeds.

On the other hand: if birds tend to eat the larger seeds and ignore the smaller ones, they will exert directional selection in favour of small seeds.

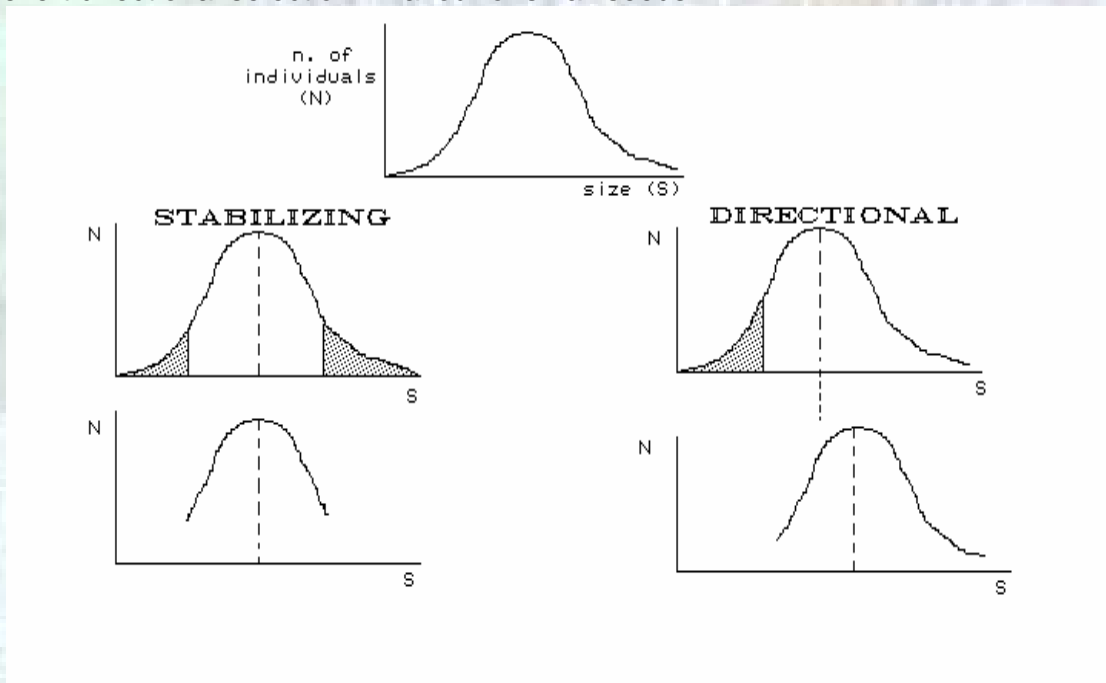

Fig. 25.2

Note that the median (dotted line representing the average size remains the same in stabilising selection, but that it has moved to the right (average size has increased) in directional selection.

A-2. DISRUPTIVE SELECTION.

Takes place when the extremes of a range of phenotypes are favoured relative to intermediate phenotypes. E.g. a type of beetle has specialised in feeding on seeds of intermediate size, ignoring the very small and vary large seeds.

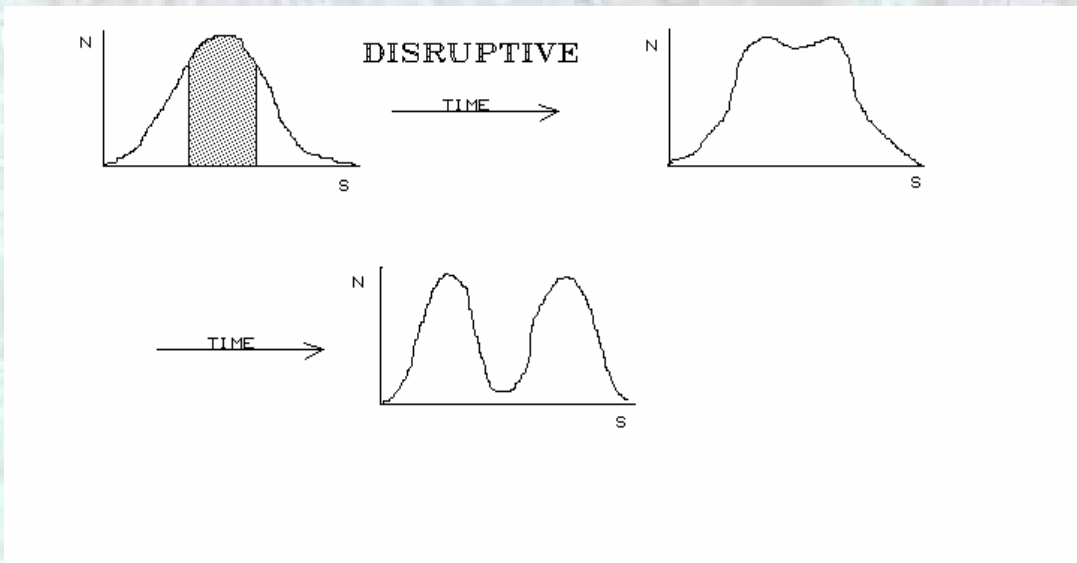

Fig. 25.3

A-3. ARTIFICIAL SELECTION.

Is done by man. We select for the best growing plants, the plants that produce most fruits, vegetables. We select for the best dogs (hunters, guard dogs, family dogs...), cows (most milk, most meat...). With these plants and animals, we cross-breed, to get all (or as much as possible) the wanted characteristics in one individual. Unless we do it on a very large scale, this way of selection plays no evolutionary role.

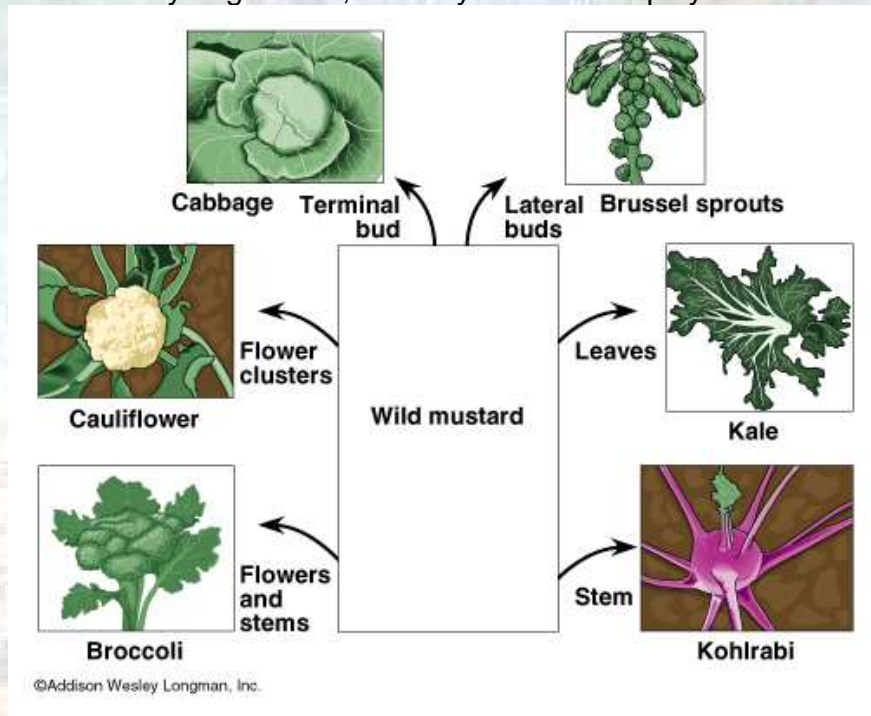

Fig. 25.4

Created by Bernard Brochez



Fig. 25.5

26. BIOLOGY EXPERIMENTS.

1. TO TEST FOR STARCH.

- label the five test-tubes 1,2,3,4 and 5
- Using the pipettes provided put about 1 cm. of:
 - starch solution in tube 1
 - glucose solution in tube 2
 - albumen solution in tube 3
 - fat suspension in tube 4
 - water in tube 5
- Use your pipette to add 3 drops of iodine sol'n to each test-tube.
- Shake each test-tube from side to side, not up and down, to mix the contents.
- Look for any colour changes apart from the yellow colour of the iodine sol'n itself

WORKSHEET SUMMARY

1 Complete the table of results

Tube	substance	Reaction with iodine
1	starch sol'n	
2	Glucose sol'n	
3	albumen solution	
4	fat suspension	
5	water	

2 what colour does the mixture go when there is a positive reaction?

3 Which of the samples gave the most striking colour change?

4 To which main class of food substances does this sample belong?

carbohydrates

proteins

fats

vitamins

5 why were the other samples included?

6 What was the point of having tube 5 as part of the exp.?

Created by Bernard Brochez

7 A sample of food was tested using iodine sol'n and it gave a positive reaction. In this sample of food, what can you say about the presence of the following substances?

- Starch
- glucose
- protein

2. TO TEST FOR A SUGAR SUCH AS GLUCOSE.

- Three-quarters fill the beaker with water and put it on the tripod and gauze.
- Light the Bunsen burner and put it under the beaker.
- While the water in the beaker is coming to the boil, label the five test-tubes 1,2,3,4 and 5.
- using the pipettes provided put about 1 cm. of
 - Starch sol'n in tube 1
 - Glucose sol'n in tube 2
 - Albumen sol'n in tube 3
 - Fat suspension in tube 4
 - water in tube 5
- Use your pipette to add 1 cm of Benedict's sol'n to each of the test-tubes.
- Keep the water boiling gently in the beaker and use it as a water bath. Use the test-tube holder to put all the test-tubes into the water bath. Leave them there for about 3 min.
- Turn off the Bunsen burner.
- Take the tubes out of the water bath and put them into the test-tube rack. Notice any colour changes that have occurred.

WORKSHEET SUMMARY

1 Complete the table of results

Tube	substance	colour change after heating with Benedict's sol'n
1	starch sol'n	
2	Glucose sol'n	
3	albumen solution	
4	fat suspension	
5	water	

Created by Bernard Brochez

2 What colour changes took place when Benedict's sol'n was added to each tube at the beginning of the exp.?

3 The sol'ns are examples of the main classes of food. With which food sample did heating with Benedict's sol'n give the most striking colour change?

4 apart from the colour, which other changes took place?

5 What was the point of having tube 5 in the exp.?

Benedict's sol'n does not give this result with all types of sugar!!!

TO TEST FOR PROTEINS.

- label the five test-tubes 1,2,3,4, and 5
- Using the pipettes provided put about 1 cm of
 - starch sol'n in tube 1
 - glucose sol'n in tube 2
 - albumen sol'n in tube 3
 - fat suspension in tube 4
 - water in tube 5
- Use your pipette to add 0.5 cm of the sodium hydroxide solution to each test-tube. RINSE the pipette.

DID YOU SPILL ANY? TELL YOUR TEACHER AT ONCE!!!!

- Shake each tube from side to side, not up and down, to mix the contents.
- Add 3 drops of the very weak copper sulphate sol'n to each of the tubes. Shake each tube from side to side again.
- Wait about 30 seconds and then look at the colour in each of the tubes.
This reaction with sodium hydroxide and copper sulphate is called BIURET TEST.

WORKSHEET SUMMARY.

1 Complete the table of results.

Tube	substance	Result of Biuret test
1	starch sol'n	
2	Glucose sol'n	
3	albumen solution	
4	fat suspension	
5	water	

Created by Bernard Brochez

2 What colour did the mixture go when mixed with the albumen sol'n? (This is the positive reaction.)

3 To which main class of food subst. does albumen belong?
(Carbohydrates, proteins, fats, vitamins)

5 What was the point of having tube 5 as part of the exp.?

TO TEST FOR FATS.

ALCOHOL IS FLAMMABLE. All flames must be put out!! All apparatus must be dry at the beginning of the exp.

- Label the four tubes 1,2,3, and 4
- Use your pipette to put about 1 cm of alcohol into tubes 1 and 2. Rinse the pipette.
- Using the pipette provided, add 1 drop of vegetable oil to tube 1. Shake tube 1 from side to side until the oil is dissolved into the alcohol.
- Collect some water in the beaker, then use your pipette to add about 2 cm of water to tubes 3 and 4.
- Pour the contents of tube 1 into tube 3.
- Pour the contents of tube 2 into tube 4.
- Now notice the appearance of the contents of tubes 3 and 4.

WORKSHEET SUMMARY.

1 Complete the table of results.

Tube	substance	Appearance after adding water
1	Alcohol+oil	
2	alcohol	

2 What was the only difference between the contents of tubes 1 and 2?

3 What difference could you see between tubes 3 and 4 after adding the contents of tubes 1 and 2?

4 What do you think caused the liquid in tube 3 to look like this?

Created by Bernard Brochez

On a **Practical exam** you will certainly have to draw a specimen.

How to calculate the magnification of your drawings.

You are drawing an object (leaf, tooth, animal ...) on a sheet of paper. It is obvious that when you are drawing an elephant, you will have to make your drawing smaller than the real elephant. If, on the other hand you are drawing a housefly, it is also obvious that you will enlarge the drawing. On an enlarged drawing you can draw much more details.

Biological drawings are made to show other people how the animal, leaf... really looks like. Therefore it is important to indicate the magnification on your paper. People might otherwise have no idea of how big the animal, leaf... is.

The example below should give you a better idea.

You see two drawings of a cat. But how big is the real cat I looked at to make these drawings??? Is it bigger than the one on the left and smaller than the one on the right? Or vice versa?

To indicate how big the cat in real life is, I have to indicate the magnification.

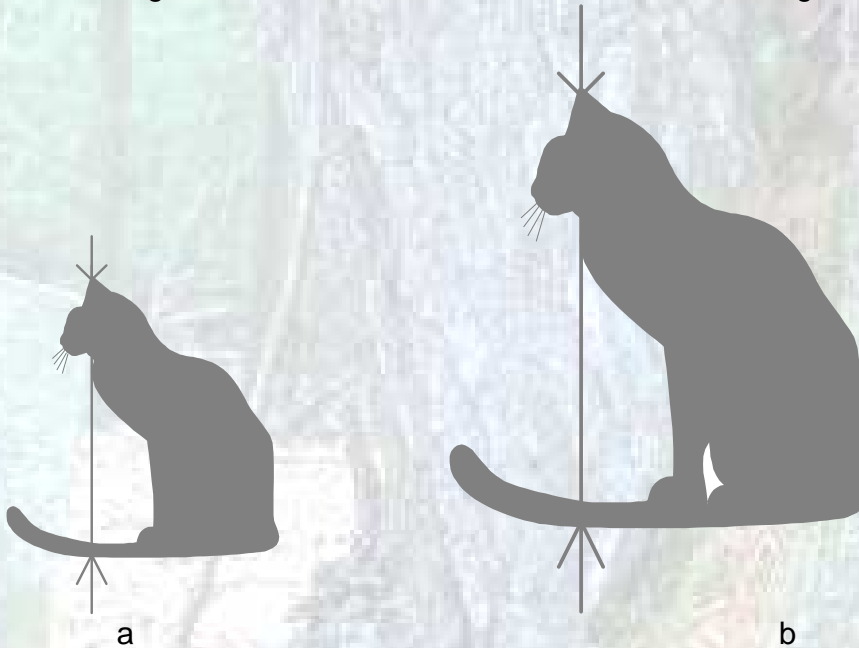

Fig. 26.1

How do you go about?

You can for instance measure the height of your drawing (see the lines with arrows on the drawing) and then measure the height of the real cat (Here, you can even estimate since your cat will run away when you approach it with a ruler).

$$\text{Magnification} = \frac{\text{drawing}}{\text{object}}$$

Created by Bernard Brochez

In our example:

Suppose the real life cat is 32 cm. high.

$$\begin{array}{l} 4 \text{ cm} \\ \text{a: } \frac{\text{-----}}{32 \text{ cm}} = 0.125 \text{ X} \end{array} \qquad \begin{array}{l} 8 \text{ cm} \\ \text{b: } \frac{\text{-----}}{32 \text{ cm}} = 0.25 \text{ X} \end{array}$$

Cat a is 8 times smaller and cat b is 4 times smaller.

The magnification which you've calculated should be rounded off, since it is not so important whether your drawing is 2.3465 times enlarged or 2.4565 times. Who cares for the correct number?? In both cases you will indicate that your drawing is 2.5 times bigger than the real object.

Magnifications are approximate. You will draw an object a quarter smaller or half smaller. You will draw it life-size (1X) or you will draw it 2,3,4,5.... times bigger.

Good magnifications are: 0.1, 0.2, 0.3, 0.5 ,0.75, 1, 1.5, 2, 2.5, 3,.....

A magnification of 1 X means that the object is as big as your drawing. If you put the object on your drawing you should not see the drawing. E.g. tracing your hand.

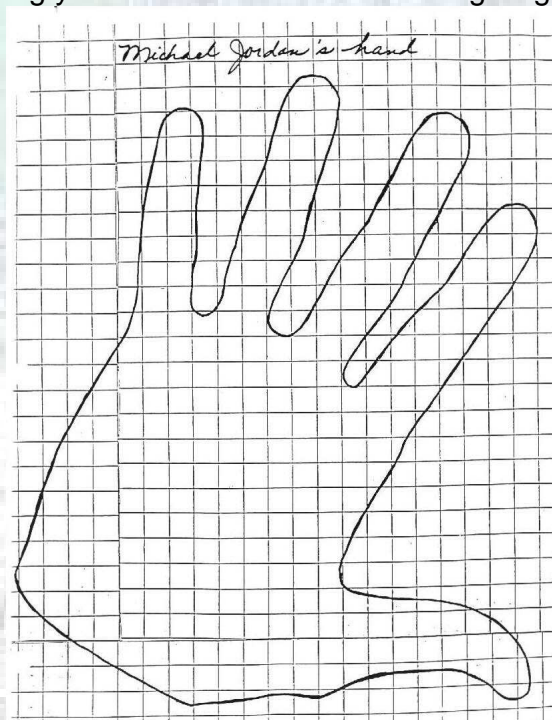

Fig. 26.2

A magnification smaller than 1 means that the drawing is smaller than the object: 0.1 X means that the drawing is 10 times smaller than the object. (see maps in an atlas: scale 1 : 25000)

Created by Bernard Brochez

A magnification bigger than 1 means that your drawing has been enlarged: 3 X means that the drawing is 3 times bigger than the object.

Exercise:

a. Calculate the magnification of both balls. The real ball with which you play football or net-ball has a diameter of 27 cm. The lines on the drawings indicate where you can measure.

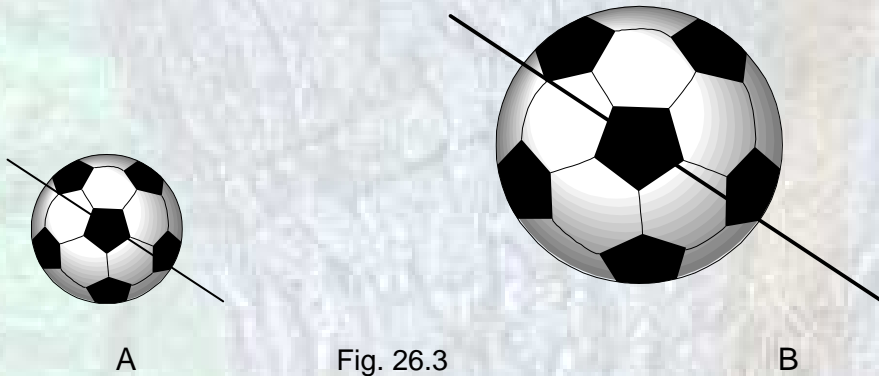

When you would be asked now to make your own drawing of ball A and if you were told that ball A was already magnified 0.01 X, you have to approach it slightly different.

First you would make your own drawing as the one you can see below.



Fig. 26.4

Your own drawing of the ball

You measure this drawing on the same line as on ball A.

Length of your own drawing

Magnification = ----- X 0.01

Length of ball A

Created by Bernard Brochez

**You still have to multiply by 0.01, ...
since the drawing A was already magnified 0.01 X!!!!**

Exercise: Calculate the magnification of the drawing of the suitcase, knowing that the real suitcase is 75 cm by 50 cm. Handle not included!



Fig. 26.5

Other practical exercises include
observation of plants, animals,
fieldwork

...

Check with your teachers.